

POT MAGNETS

SERIES 239:

- Has unlimited applications such as magnetic fasteners, displays, holding maps etc.
- Has tapped hole of 1/4" - 20
- Comes with Plated Keepers



Order No.	Diameter	Height	Pull	Price
2391116	11/16"	5/8"	6 lbs.	
2391316	13/16"	3/4"	10 lbs.	
2391016	1-1/16"	1"	14 lbs.	
2390138	1-3/8"	1-3/16"	30 lbs.	



MAGNETIC WELDING LINK

SERIES 239:

- Ideal for holding steel parts for welding, brazing etc.
- Wing nut adjustment.
- No clamp needed
- Two heavy magnetic blocks 2-3/8"(60mm) long x 1-1/8"(28mm) square linked together for easy adjustment.

Order No.	Price
9990001	



SHALLOW POT CERAMIC MAGNETS

SERIES 239:

- Permanent, Powerful Magnets to hold, lift and attract metal parts.
- Shallow Depth permits use in confined spaces
- Model 2390134 has 10 x 24 threaded Center Hole for fastening with machine screw.
- Large Sizes have 3/8" clearance holes for fastening with rods or bolts.



Order No.	Diameter	Depth	Pull	Price
2390134	1-3/4"	1/4"	10 lbs.	
2390200	2"	3/8"	20 lbs.	
2390234	2-3/4"	7/16"	35 lbs.	
2391138	3-1/8"	1/2"	50 lbs.	



MAGNETIC SEPARATOR

SERIES 239:

- Specially designed for separating ferrous sheets or particles.
- Very useful in workshops for cleaning machine beds, agriculture industry, etc.
- Powerful magnetic force can be demagnetized by simply pulling up the handle.



Order No.	Length x Width x thickness	Price
9990002	9-1/4 x 5-1/4 x 1" / 235 x 135 x 25mm	



EXTRA POWER MAGNETIC HOLDFASTS

SERIES 239:

- Have tremendous power.
- Provided with Push Off Screw to push work away from the holdfasts as this cannot be done by hand.
- Also provided with plated Keepers which protect and retain magnetic field.
- Can be used to hold work for welding, grinding. Ideal for making inexpensive lifting devices and jigs.
- Have many applications in material handling and machine shop.



Order No.	Diameter	Magnetic Pull	Price
2391340	1-3/4"	45 lbs.	
2392180	2-1/8"	70 lbs.	
2392340	2-3/4"	110 lbs.	



MAGNETIC RACK (ORGANIZER)

SERIES 239:

- Very handy for holding tools parts of assembly, jigs, parts for dipping, painting, sand blasting etc.
- Beautifully finished with white powder coating.



Order No.	Length	Price
9990012	12"/300mm	
2390018	18"/450mm	
2390024	24"/600mm	



MAGNETIZER / DEMAGNETIZER

SERIES 802:

Wiha magnetizer/demagnetizer magnetizes steel screwdriver blades, tweezers and similar tools. Box high quality plastic, shock-resistant, cadmium free. Magnetize by leading tool through + opening and demagnetize by leading tool through - opening. Dimensions: 2.1" x 2.0" x 1.1"



Order No.	Description	Price
40010	Magnetizer/Demagnetizer	

MAGNETIC QUICK CLAMPS

SERIES 239:

- Designed to enable fast and accurate holding of ferrous metals for welding and assembly.
- Small compact design with powerful magnetic force.
- Body holes enable the clamps to be built into jigs or hung when not in use.



Order No.	Diameter	Angles	Price
2394258	4-3/8" x 3-3/4"	30°, 90°, 135°	
2394380	4" x 2-5/8"	30°, 45°, 60°, 75°, and 90°	

ALNICO MAGNETS

SERIES 213:

Aluminum, nickel and cobalt alloy makes General's Alnico line of magnets strong, and permanent. Under normal working conditions and temperatures, Alnico magnets will retain their magnetic force indefinitely. Removable keepers insure permanence. All weights and measurements are approximate.

GENERAL

GENERAL

Button Type Alnico Magnets

- Button shaped magnet has almost unlimited applications.
- Retrieves screws and steel parts.
- Center hole in top of magnet for easy fastening.



372C 372E

Model No.	Dia.	Ht.	Pull	Cored Hole	Order No.	Price
372A	1/2"	3/8"	1-1/2 lbs.	1/8"	42073	
372B	3/4"	1/2"	4 lbs.	1/8"	42076	
372C	1"	5/8"	6-1/2 lbs.	3/16"	42079	
372D	1-1/4"	3/4"	14 lbs.	3/16"	42082	
372E	1-1/2"	7/8"	18-1/2 lbs.	1/4"	42085	

Alnico Shallow Pot Magnets

- Our best quality shallow pot magnets.
- Shallow depth permits use in confined spaces.
- Alnico metal capable of withstanding extreme heat. Will not lose magnetism.



Model No.	Dia.	Pull	Depth	Hole	Order No.	Price
378A	0.75"	7bs.	.313"	.147"	42126	
378B	1.125"	11 lbs.	.344"	.190"	42129	
378C	1.50"	29 lbs.	.406"	.190"	42130	

Pocket Horseshoe Alnico Magnets

- Small but powerful magnet.
- For retrieving small steel parts and screws from hard-to-get-at places.
- 1/4" opening between poles



370-1

Order No.	Model No.	Size	Pull	Price
42041	370-1	1 oz.	2-1/4lbs.	

Magnetizer/ Demagnetizer

- Powerful magnet specially designed for magnetizing and demagnetizing screwdrivers, nut drivers, wrenches, taps and small tools.
- Converts any tool blade into a magnetic retriever for screws, nuts and metallic particles.



Order No.	Model No.	Dimensions	Price
42021	360	1"x1"x1"	

Pot Alnico Magnets

- Unique combination of strong magnet with insulating ring gives this magnet the superior holding power of larger ones.
- 1/4" diameter x 20 threads-per-inch hole for attaching to fixtures and machines.



Model No.	Dia.	Height	Pull	Wt.	Order No.	Price
374A	11/16"	5/8"	6 lbs.	6 oz.	42093	
374B	13/16"	3/4"	10 lbs.	6 oz.	42096	
374C	1-1/16"	1"	18 lbs.	12 oz.	9942102	
374D	1-3/8"	1-3/16"	35 lbs.	24 oz.	9942105	

Pickup Stick™/ Sweeper

- An ideal tool for retrieving iron, steel & all ferrous materials
- Powerful, permanent magnet for a no-stoop pickup.
- Vinyl-coated magnet for long-life and durability.
- 37-inch steel shaft for greater strength and durability.
- Plastic handle grip for greater control and comfort.
- Sweeper width 24 inches.



Order No.	Model No.	Price
31434	397 Pickup Stick	
22189	354 Sweeper	

Shallow Pot Ceramic Magnets

- Shallow depth permits use in confined spaces.
- Nos. 376A and 376B have 3/16" diameter clearance holes for fastening with rods or bolts.
- Nos. 376C and 376D have 9/32" diameter clearance holes.



Model No.	Dia.	Depth	Pull	Order No.	Price
376A	1-3/8"	3/16"	12 lbs.	42111	
376B	2"	1/4"	20 lbs.	42114	
376C	2-5/8"	3/8"	35 lbs.	42117	
376D	3-1/4"	7/16"	50 lbs.	42120	

Power Alnico Magnets

- Strong magnetic pull for lifting, holding, sorting, clamping or retrieving steel or iron parts.
- Hole in top of magnet for attaching conveyors, racks, and welding jigs.



Model No.	Size oz.	Approx. Pull Lbs.	Width In.	Height Inches	Pole Depth In.	Pole Width In.	Opening Between Poles In.	Cored Hole In.	Wt. ea. with Keeper	Order No.	Price
370-2	2	13	1-1/8"	3/4	3/4	1/4	9/16	3/16	3 oz.	42044	
370-3	3	17	1-5/16"	1-3/8	5/8	3/8	5/16	-	4 oz.	42047	
370-4	4	22	1-1/2"	1	1	5/16	3/4	3/16	5 oz.	42050	
370-6	6	30	1-3/4"	1-1/8	1-1/8	5/16	7/8	3/16	8 oz.	42053	
370-8	8	32	2-3/16"	1-13/16	15/16	1/2	1-3/16	3/16	10 oz.	42056	
370-10	10	37	2-7/16"	2	15/16	5/8	1-3/16	3/16	13 oz.	42059	
370-12	12	42	2-5/8"	2-1/4	15/16	5/8	1-3/8	3/16	15 oz.	42061	
370-16	16	50	3"	2-1/2	15/16	3/4	1-1/2	3/16	20 oz.	42064	
370-24	24	70	2-1/2"	1-13/16	1-7/8	5/8	1-3/8	1/4	28 oz.	42067	

GENERAL

MAGNETIC TOOLS

SERIES 213:

GENERAL

While we show only the popular GENERAL items we can supply their entire range of products; please inquire.

368



Magnetic Strip

- Our flexible magnetic strip with adhesive backing adheres to most smooth surfaces.
- Holds small metal objects.
- 1/16" thick and easily cuts to desired length with scissors or knife.

Model No.	Size	Order No.	Price
366	1/2"x30"	42027	
367	1/2"x10'	42030	
367-100	1/2"x100'	42031	
368	1"x30"	42033	
369	1"x10'	42036	
369-100	1"x100'	42038	

Pickup/ Release Magnet

- A one-hand operated magnetic tool for picking up and releasing iron and ferrous objects.
- Wide 4" diameter magnetic surface holds more pieces.
- 16 lbs. of lifting power.
- Ideal for cleaning-up around power equipment such as drill presses, milling machines and lathes.



Model No.	Pull	Order No.	Price
379	16 lbs.	42123	

Quality Industrial Supplies

MEGA Superior Import

Starrett

GENERAL

The Choice Is Yours!!!

General's magnetic pickups are an excellent tool for retrieving small steel and iron parts from hard-to-reach places. The high power neodymium magnet is six times more powerful than a cobalt magnet of the same size and density.



Pocket Magnetic Pickups

- Powerful permanent magnet in a knurled aluminum holder with handy pocket clip.
- No. 386 has a high-powered neodymium magnet which is six times more powerful than a cobalt magnet of the same size and density.
- Ideal for retrieving small steel and iron parts from hard-to-reach areas.
- Small magnet size actually measures 2/10" x 1/4".
- Measures 5-1/2" overall.

Model No.	Magnet	Pull	Order No.	Price
386	NEO	2 lbs.	42219	

Telescoping Magnetic Pickups

- A powerful permanent magnetic pickup tool.
- Ideal for retrieving steel and iron parts from hard-to-reach work areas.
- Magnet is fitted in a 5-1/2" long nickel plated steel handle that can extend up to 23-1/2".
- Holder is fitted with a pocket clip.

Model No.	Pull	Order No.	Price
383NX	2 lbs.	9942208	

Magnetic Pickup With Pivot Joint

- An excellent tool for retrieving small steel parts from hard-to-reach places.
- High-power neodymium magnet lifts up to two pounds and will never lose its magnetism.
- 8-3/4" overall length.
- Locking pivot joint allows user to pick up objects around corners.
- Nickel plated steel body with cushion grip handle
- Pocket clip for convenient storage

Model No.	Pull	Order No.	Price
392	2 lbs.	42224	

Flex-o-Stiff Magnetic Pickup

- An ideal tool for retrieving steel parts from hard-to-reach places.
- No. 384N has a high-powered neodymium magnet which is six times more powerful than a cobalt magnet of the same size and density.
- Permanent magnetic power.
- Magnet is fitted into an 18" nickel plated holder, which can be extended to a 32" flexible retriever.

Model No.	Magnet	Pull	Order No.	Price
384N	NEO	2 lbs.	42210	

Extra-Long, Magnetic Pickup With Pivot Joint

- An excellent tool for retrieving steel parts from hard-to-reach places.
- High-power neodymium magnet lifts up to 5 lbs. and will never lose its magnetism.
- Steel body measures 13" and can be extended to 27".
- Locking pivot joint allows user to pick up objects around corners.
- Body is chrome plated, with a vinyl cushion grip handle.

Model No.	Pull	Order No.	Price
394	5 lbs.	42228	

Bendable Magnetic Pick-Up

- An excellent tool for retrieving steel parts from hard-to-reach places.
- High-power neodymium magnet is six times more powerful than a cobalt magnet of the same size and density.
- Knurled aluminum body with bendable 15" wire.
- Overall length is 20".
- Lifts up to 2 pounds.

Model No.	Pull	Order No.	Price
395	2 lbs.	42229	

ADAPTER PIN CHUCK SET SERIES 306:



- For use with miniature drills.
- Lock this adapter in chuck to convert it for precise drilling.
- Also adapts 3/32" (2.40mm) Collets on rotary tools and flexible shafts to a more useful 0 to 3/32" (0 to 2.40mm)
- Comes with two sets of jaws (Capacity 0 to 1/16" (0 to 1.60mm) and 1/16" to 3/32"(1.60mm to 2.40mm)
- Shank diameter 3/32" (2.40mm), Shank length 1-3/8" (34.90mm)
- Overall length 2-5/8" (66.50mm)

Order No.	Price
3100200	



SINGLE-END PIN VISES SERIES 306:



- Ideal vise for holding small tools, rods, wires, taps etc.
- Collets grip firmly when screw chuck is tightened.
- Heavy knurled body.
- Black shiny finish
- Available in individual sizes and also in a set of four in attractive plastic pouch.

Order No.	Capacity		Overall Length	Price
	Inch	mm		
3060001	0.000 to .040"	0 to 1.0	3-3/8"/85mm	
3060002	0.031 to .060	0.8 to 1.5	3-5/8"/92mm	
3060003	.052 to .125	1.3 to 3.1	3-3/4"/95mm	
3060004	.120 to .192	3.0 to 4.85	4-1/8"/105mm	
1900000	Set of four in a plastic pouch			

PIN VISE - SLIDING AND MINI SERIES 306:



Sliding pin vise features a sliding, knurled ring to close jaws making it easy to operate.
Mini pin vise features a heavy knurled brass body.

Order No.	Description	Capacity	Overall Length	Price
3060013	Sliding Pin Vise	0 to 3/64"(0 to 1.3mm)	4-1/8"/105mm	
3060014	Mini Pin Vise	0 to 1/32"(0 to .7mm)	3-1/8"/80mm	

KEY CADDY SERIES 791:



Heavy duty chrome-plated die-cast case with stainless steel key ring. Returns keys and other articles automatically. For custodians, maids, watchmen, service station attendants and many others. Great for welders to carry torch ignitors. Available with regular belt clip that clips over belt, or a looped clip that the belt feeds through.

Description	Catalog No.	EDP No.	Price
Regular Belt Clip	SK1	63135	

PIN CHUCK SET SERIES 306:



- Designed for holding small drills
- Black shiny finish.



Order No.	Description	Price
1920000	A knurled chuck with 1/4" diameter shank holds all three collets: 0-1/32" 0-0.8mm 1/32" -1/16" 0.8-1.60mm 1/16"-3/32" 1.6-2.40mm	

ADJUSTABLE PIN VISES SERIES 306:



- 3 jaw steel screw chuck
- Unbreakable plastic handle
- Ideal tool for holding small drills, burs, wires, reamers and other miniature tools.
- Extensively used in electronic assembly, tool making and has many applications.

Order No.	Capacity		Overall length	Price
	Inch	mm		
3060009	0 to 1/4	0 to 6.35mm	6-3/16"/155mm	
3060010	1/8 to 1/2	3.2 to 12.7mm	6-1/2"/165mm	

DOUBLE END PIN VISE (4 JAW) SERIES 306:



- Has two four jaw double end collets.
- Very popular with jewelers, watch makers, model makers etc.

Order No.	Capacity	Overall Length	Price
3060012	0 to 1/8" 0 to 3.2mm	4"/100mm	

HAND DRILL AND PIN VISE WITH SWIVEL HEAD MASTER PIN VISE SERIES 306:



- Has two double-end collets with swivel head.
- Screw chuck tightly holds miniature tools.
- Bright Nickel plated finish.

Order No.	Capacity	Overall Length	Price
3060011	0 to 1/8" / 0 to 3.2mm	3-5/8"/95mm	

PIN VISES

STARRETT
SERIES 162:



For holding wires, scriber points, small files, taps, drills, etc. A hole extends through full length of handle to hold wires of any length. Knurled handle is reduced in size so it may be rapidly rotated between thumb and finger when filing small work. Handle and binding nut are nickel plated.

Range, English	Range, Metric	Catalog No.	Order No.	Price
0 - .040"	0 - 1mm	162A	50599	
.030 - .062	0.8 - 1.6	162B	50600	
.050 - .125	1.3 - 3.2	162C	50601	
.115 - .187	2.9 - 4.8	162D	50602	
Set of all 4 sizes Nos. 162A, B, C, D without case		S162	50603	
Set of all 4 sizes in protective vinyl case		C162Z	50604	

PIN VISES

STARRETT
SERIES 166:



Same as Starrett Model 162 Series except made with an insulated PVC handle which is octagon in shape to prevent rolling when laid down.

Range, English	Range, Metric	Catalog No.	Order No.	Price
0 - .040"	0 - 1mm	166A	50609	
.030 - .062	0.8 - 1.6	166B	50610	
.050 - .125	1.3 - 3.2	166C	50611	
.115 - .187	2.9 - 4.8	166D	50612	
Set of all 4 Sizes, Nos. 166 A,B,C,D, without case.		S166	50613	
Set of all 4 Sizes in protective vinyl case		S166Z	50614	

PIN VISES

STARRETT
SERIES 240:



Smooth section on handle allows vise to be held in machine chuck or collets. Handle has hole through entire length to accommodate stock up to full size capacity so that long rods can be gripped close to the end. End of handle is knurled and has a smaller diameter than chuck which allows fast opening and closing and rapid rotation between the thumb and finger when used on small work. All four vises have heavy nickel plated finish.

Catalog No.	Order No.	Range		Price
		English	Metric	
240A	51136	.010-.055"	.25-1.4mm	
240B	51137	.025- .75"	0.64-1.9mm	
240C	51138	.045 - .135"	1.2-3.4mm	
240D	51139	.110 - .200"	2.8-5.1mm	
S240Z	51140	Set complete: .010 - .200" consisting of No. 240A, B, C, D, in protective case		

THIRD HAND

SERIES 442:



- Very handy holding device with horse shoe base.
- Heavy, Non - tipping base equipped with ball joint attachments which can position work at any angle.
- Various types of clamps will fit on these bases.
- Handy for positioning pieces to be joined by solder or adhesive, freeing both hands.
- Very useful for jewelers, assemblers, model makers and hobbyists.
- Available with or without Magnifier

Order No.	Description	Price
4420030	Third Hand	
4420031	Third Hand with 2-1/2"(63mm) Magnifier	

PICKUP TOOL - DIAMOND HOLDER
SERIES 442:



- Ideal tool for picking & holding small items.
- Chrome plated knurled body.
- Very handy tool for machinists, jewelers, assemblers and mechanics.

Order No.	Description	Length	Price
3091243	Std. pick-up-tool-3 prong	4-5/8"/115mm	

MECHANICAL PICKUP

SERIES 213:



- Strong four prong steel jaws retrieve small items from hard-to-reach places.
- 24" (60cm) reach.
- Smooth actuator for greater control.
- Chrome finish to prevent rust.
- Flexible shaft to avoid obstacles.

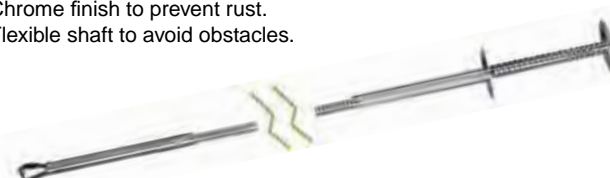

Model No.	Order No.	Price
396	22145	

TWEezer SET SERIES 639:

Industrial quality.
6 piece assortment
in plastic pouch.



MEGA
Superior Import



While we show only the most popular **GENERAL** items we can supply their entire range of products. See our website or inquire.

Order No. 6390000

Price

TWEezERS

SERIES 213:

General's precision tweezers are used for electronics, computer, instruments, radio and other small or subminiature assembly, servicing and repairs. The industrial tweezers of General's quality line are used by toolmakers, repair-people electronic assemblers and other professionals and the utility tweezers are used by mechanics, crafts-people and hobbyists.



PRECISION TWEezERS

For electronic, computer, instrument, radio and other small or subminiature assembly, servicing and repairs.

INDUSTRIAL TWEezERS

General's quality tweezers for toolmakers, repairmen, electronic assemblers and other professionals.

UTILITY TWEezERS

Utility tweezers for mechanics, crafts people and hobbyists.

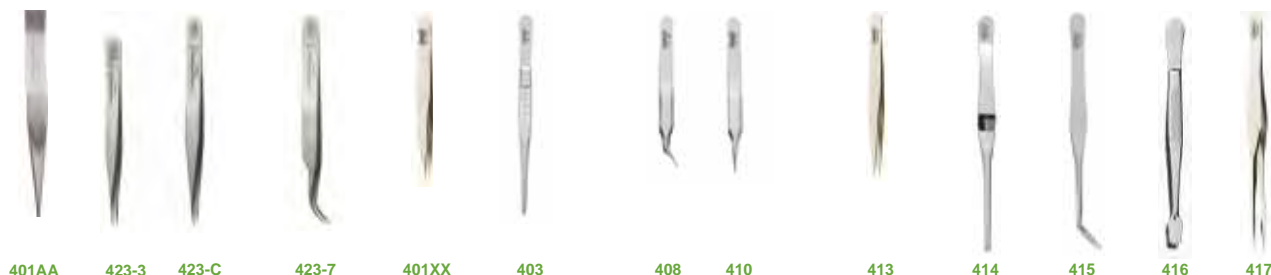

BOLEY PATTERN TWEezERS

- A fine quality tweezer for jewelers, watchmakers, instrument assemblers and crafts people.
- For radio, television and other repairs.

Model No.	Point Style	Length	Order No.	Price
401AA	Strong bevel	5"	42240	

Individual Styles of Industrial Tweezers

Model No.	Point Style	Lgth	Order No.	Price
401XX	Strong point	4-1/2"	42263	
403	Blunt serrated	6"	42266	
408	Sharp bent	4-1/4"	42271	
410	Narrow sharp	4-1/4"	42280	
413	Sharp	4-1/2"	9942289	

SWISS PATTERN TWEezERS

- Light tension and hardened points for subminiature assemblies.
- Stainless steel construction.

Model No.	Point Style	Length	Order No.	Price
423-3	Very fine	4-5/8"	42249	
423-3C	Very fine	4-1/8"	42251	
423-7	Curved fine	4-1/2"	42257	

Individual Styles Of Utility Tweezers

Model No.	Point Style	Length	Order No.	Price
414	Blunt serrated (self closing)	6-1/2"	42291	
415	Curved	6-1/2"	42294	
416	Spade	4-1/2"	42397	
417	Long straight	6-1/2"	42300	

TWEezer MAGNIFIER

- Useful for detailed projects.
- 5-Power lens.
- Stainless steel tweezer.
- Double hinged adjustable arm.
- Durable plastic handle and frame.



Model No.	Order No.	Price
425	42258	

SIX PEEce TWEezer SET

- Consists of six tweezers for home and industrial use.
- One each of Nos. 401XX, 403, 412, 414, 415, 417.
- In clear vinyl pouch.

Model No.	Order No.	Price
C421	42309	



EYE LOUPES

SERIES 510:

- High quality precise Eye loupes.
- Lens made of clear ground and polished optical glass.
- Body made form black polished plastic.
- Hands - Free magnification.
- Must for toolmakers, instrument assemblers, watchmakers and hobbyists.



Order No.	Mag. Power	Focal Length	Price
5100002	2x	4.5"/114mm	
5100025	2.5x	4.0"/102mm	
5100003	3x	3.5"/89mm	
5100035	3.5x	3.0"/76mm	
5100004	4x	2.5"/63mm	
5100045	4.5x	2.25"/57mm	
5100005	5x	2.0"/50mm	
5100007	7x	1.5"/38mm	
5100010	10x	1.0"/25mm	
5100110	10x Double lens	1.0"/25mm	
5100050	5PC set of 2x, 3x, 4X, 5x, and 10x(double lens) eye loupes		

ROUND MAGNIFIERS

SERIES 510:

- Plastic handle light weight magnifiers ideal for engineers, professional and hobbyists.
- Ideal reading glass assuring edge to edge clarity.
- Available in different sizes and magnifications.



Order No.	Length Diameter	Focal Length	Power	Price
5100112	1-1/2"40mm	4"/10CM	3.5x	
5100250	2"/50mm	6"/15CM	2.5x	
5100212	2-1/2"/60mm	6"/15CM	2.5x	
5100375	3"/75mm	8"/20CM	2.25x	
5104100	4"/100mm	8"/20CM	2.25x	
5104000	4 PC set consisting of 1-1/2" (40mm), 2"(50mm) 3" (75mm), 4" (100mm) lens diameter magnifiers			

FLASHLIGHT MAGNIFIER

SERIES 510:

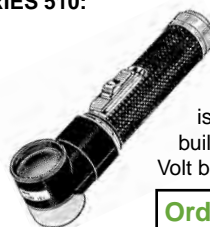

This magnifier with 10x magnification is an excellent instrument. It features a built-in lighting device that works on two 1.5 Volt batteries.



Order No. 1001966	Price
-------------------	-------

FOLDING POCKET MAGNIFIERS - LEATHER CASE

SERIES 510:

- Handy Pocket magnifiers.
- Ground and polished optical glass.
- Leather pouch serves both as a handle and as a protective case.

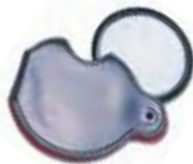

Order No.	Mag. Power	Focal length	Price
5100040	4X	2-1/2" 6.3mm	

FOLDING POCKET MAGNIFIERS - TRIPLET

SERIES 510

- High power inspection magnifiers for machinists, laboratory technicians and students.
- Made of three optical lenses.
- Lens can be used in combination to produce different powers.
- Swing away case of tough durable plastic.



Order No.	Mag. Range	Focal Length	Price
5100047	4x, 7x, 10x	2.5,1.5,1.0"	6, 3.8, 2.5cm

SEE MORE MICROSCOPES, COMPARATORS, AND MAGNIFIERS IN THE PRECISION TOOL SECTION



MAGNIFIERS

SERIES 213:



General's Magnifiers are used by toolmakers, jewelers, instrument assemblers, laboratory technicians, engineers, mechanics and inspectors who need sharp clear magnification without eyestrain.

4 Power Pocket Illuminated Magnifier

- Handy 4 power magnifier has plastic body and lens.
- Comes with 2 AAA batteries and No. 222 Bulb.



Order No.	Model No.	Price
42456	553	

(Continued)

MAGNIFIERS (Continued)

SERIES 213:

GENERAL

GENERAL

General's Magnifiers are used by toolmakers, jewelers, instrument assemblers, laboratory technicians, engineers, mechanics and inspectors who need sharp clear magnification without eyestrain.

Oblong Magnifying Reading Glass

- Powerful ground and polished glass lens.
- Lens is 2" x 4" with 1.25 power magnification.
- Plastic frame and ribbed handle.



Order No.	Model No.	Focal Lgth.	Price
42437	548	8"	

4" Illuminated Magnifier

- 4" diameter with 3 power lens covers large areas of print.
- 5 power 2" dia. bifocal lens insert gives even greater magnification.
- Bulb gives wide circle of illumination.
- Plastic body and optical plastic lens.
- Replaceable bulb and 2 C batteries included.

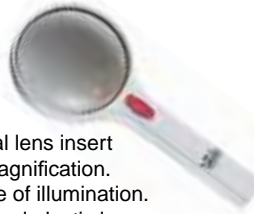

Order No.	Model No.	Focal Lgth.	Price
42462	554	3 - 1/3"	

Oblong Illuminated Magnifier

- Lens measures 2" x 4" for distortion-free magnification of large areas.
- Reversible light reflector adapts for right-hand or left-hand use.
- 2.5 power shatterproof lens, with 5 power 2" dia. bifocal insert.
- Replaceable bulb and 2 AA batteries are included.



Order No.	Model No.	Focal Lgth.	Price
42509	565	4"	

5-1/2" Magnifier

- Economical and versatile magnifier for laboratory and industrial uses, for do-it-yourselfers, mechanics and inspectors.
- 2" diameter with 4 power lens.
- Lightweight, durable 1- piece molded plastic frame.

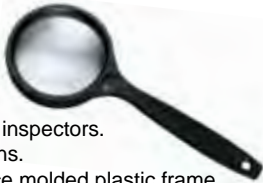

Order No.	Model No.	Focal Lgth.	Price
42414	538	2"	

INDUSTRIAL SUPPLIES

GENERAL

INSPECTION MIRRORS AND MAGNIFIERS

GENERAL

SERIES 213:

Inspection mirrors facilitate inspection of inaccessible workpieces and machines by toolmakers, assemblers, inspectors and mechanics. Fully polished mirrors are enclosed in plated holders which are attached to knurled handles with ball and socket joints. Telescoping arms and vinyl cushion grip handles are offered on some mirrors.

2.5 POWER POCKET MAGNIFIER

- Has 2.5 power ground and polished optical glass.
- Folds into case for storage.
- 4" Focal Length



Order No.	Model No.	Case	Price
42400	532	Simulated Leather Case	

MAGNETIC BASE INSPECTION MIRROR

- Adjustable 3-1/2" x 2" oblong inspection mirror mounted to a permanent magnet.
- Attaches to any steel or iron machine, tool, appliance or other equipment.
- Has wing nut ball joint adjustment.



Model No.	Order No.	Price
MB560	42475	

EYE LOUPES

- For toolmakers, jewelers, instrument assemblers and others who need sharp, clear magnification without eyestrain.
- Clear optical glass lenses are ground and polished.
- 1" diameter lens.



Model No.	Power	Focal Length	Order No.	Price
527	5.0	2"	42339	

FOLDING POCKET MAGNIFIERS

- Fine quality magnifiers for laboratory technicians, engineers, mechanics and inspectors.
- Case and lens rims are made of black molded plastic.
- Available in single lens and double lens models.



Model No.	Mod.	Ind. Power	Total Power	Lens Dia.	Focal Lgth.	Order No.	Price
533	Single	4.0	4.0	1"	2.5"	42403	
536	Double	4.0	8.0	1"	1.25"	42409	
537	Double	3.0	6.0	1-1/4"	1.6"	42412	



INSPECTION MIRRORS

Model No.	Size	OAL	Order No.	Price
555	1-1/4" Dia.	8"	42465	
557	2-1/4" Dia.	10-1/2"-15"	42468	
558	1x2" Oval	9"	42471	
560	3-1/2"x2" Oblong	11-1/2"-16"	42473	

LEXAN INSPECTION MIRRORS

Model No.	Size	OAL	Order No.	Price
577	2-1/4" Dia.	10-1/2"-15"	42480	
570	3-1/2"x2" Oblong	11-1/2"-16"	42477	

REPLACEMENT MIRRORS With Frames

Model No.	Order No.	Price
557RMF for No. 557	42481	
560RMF for No. 560	42484	



EDROY PRODUCTS

SERIES 961:



MAGNI-FOCUSER®

Features:

- No center post allows 20% increased viewing.
- Shatter and scratch resistant lens.
- Flips up for instant switch from magnification to regular vision.
- Headband is adjustable to head size.
- Lens plates interchangeable, and can be purchased separately.
- Lens size 3-1/8x1-1/8".

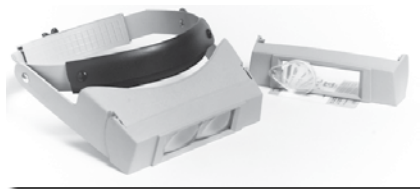

Power	Working Distance	Diopter	Order No.	Price
1.50X	20"	+2D	9610102	
1.75X	14"	+3D	9610103	
2.00X	10"	+4D	9610104	
2.25X	8"	+5D	9610105	
2.75X	6"	+7D	9610107	
3.50X	4"	+10D	9610110	

MAGNI-FOCUSER® WITH LIGHT

Same features as Magni-focuser but with 6,000 candle Power Xenon Lazer Spot® Super Beam outshines all others. Burn time 6-7 Hours. Includes AA Energizer® Alkaline Batteries.

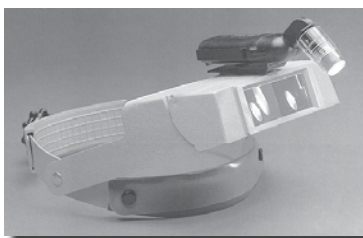

Power	Working Distance	Diopter	Order No.	Price
1.50X	20"	+2D	9611022	
1.75X	14"	+3D	9611033	
2.00X	10"	+4D	9611044	
2.25X	8"	+5D	9611055	
2.75X	6"	+7D	9611077	
3.50X	4"	+10D	9611100	

OPTICAID®

For use with any eyeglass frame. Flexible wire clip. Case included. The #1 clip-on magnifier since 1971.

- Ophthalmic quality
- Hard-coated scratch resistant acrylic lenses
- Comfortable
- Lightweight
- Reduces eye fatigue
- Swings out of line of vision when not in use



Power	Working Distance	Diopter	Order No.	Price
1.50X	20"	+2D	9610712	
1.75X	14"	+3D	9610713	
2.00X	10"	+4D	9610714	
2.25X	8"	+5D	9610715	
2.75X	6"	+7D	9610717	
3.50X	4"	+10D	9610710	

Auxiliary Lens Model

Power w/Lens	Working Distance w/o Aux.	Working Distance w/ Aux.	Order No.	Price
4.25X	14"	4"	9610113	
4.50X	10"	3.5"	9610114	
4.75X	8"	3"	9610115	
5.25X	6"	2"	9610117	

Auxiliary Lens Model

Power w/Lens	Working Distance w/o Aux.	Working Distance w/ Aux.	Order No.	Price
4.25X	14"	4"	9610133	
4.50X	10"	3.5"	9610144	
4.75X	8"	3"	9610155	
5.25X	6"	2"	9610177	

MAGNI-SPECS™

Features:

- Only 1.2 ounces.
- ABS brow bar, nose piece and post Zyl temples.
- Can be worn alone or over eyeglasses.
- Lens flip out of line of sight.
- Hard protective case included.



Power	Working Distance	Diopter	Order No.	Price
1.50X	20"	+2D	9610002	
1.75X	14"	+3D	9610003	
2.25X	8"	+5D	9610005	
2.75X	6"	+7D	9610007	
3.50X	4"	+10D	9610000	

SPRING CLIP OPTICAID®

Same as above but with spring clip.

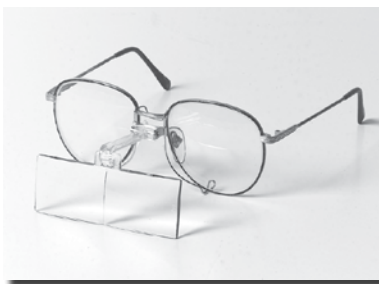

Power	Working Distance	Diopter	Order No.	Price
1.50X	20"	+2D	9610912	
1.75X	14"	+3D	9610913	
2.25X	8"	+5D	9610915	
2.75X	6"	+7D	9610917	
3.50X	4"	+10D	9610910	

SEE MORE MICROSCOPES, COMPARATORS, AND MAGNIFIERS IN THE PRECISION TOOL SECTION





COMBINATION WRENCHES AND SETS

SERIES 871:

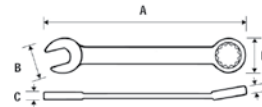

INDUSTRIAL SUPPLIES

5 PIECE (12 Pt.) SET			
Order No. 29022		Price <input type="text"/>	
Order No.	Description	Order No.	Description
20206	5/16"	0920211	9/16"
0920208	3/8"		
20209	7/16"	Pouch	
20210	1/2"		

7 PIECE (12 Pt.) SET			
Order No. 29014		Price <input type="text"/>	
Order No.	Description	Order No.	Description
0920208	3/8"	0920213	11/16"
20209	7/16"		
20210	1/2"	20214	3/4"
0920211	9/16"		
20212	5/8"	Tool Roll	

14 PIECE (12 Pt.) SET			
Order No. 29010		Price <input type="text"/>	
Order No.	Description	Order No.	Description
0920208	3/8"	0920216	7/8"
20209	7/16"		
20210	1/2"	0920217	15/16"
0920211	9/16"		
0920212	5/8"	0920219	1-1/16"
0920213	11/16"		
20214	3/4"	0920218	1"
0920215	3/16"		
		0920220	1-1/8"
		20222	1-1/4"
Tool Roll			

11 PIECE (12 Pt.) METRIC SET			
Order No. 29017		Price <input type="text"/>	
Order No.	Description	Order No.	Description
20307	7mm	20314	14mm
20308	8mm		
20309	9mm	20315	15mm
20310	10mm		
20311	11mm	20317	17mm
20312	12mm		
20313	13mm	20319	19mm
Tool Roll			

18 PIECE (12 Pt.) INCH / METRIC SET			
Order No. 29020		Price <input type="text"/>	
Order No.	Description	Order No.	Description
20470	1/4"	20417	11mm
20471	5/16"		
20472	3/8"	20418	12mm
20473	7/16"		
20474	1/2"	20419	13mm
20475	9/16"		
20476	5/8"	20420	14mm
20477	11/16"		
20478	3/4"	20421	15mm
20416	10mm		
High Density Polyethylene Case			

12 PT. COMBINATION WRENCHES							
Size	Dimensions (Inch)					Order No.	Price
	A	B	C	D	E		
1/4"	3.99	.54	.18	.38	.23	20204	
5/16"	4.38	.72	.20	.47	.25	20206	
3/8"	5.32	.81	.20	.56	.29	0920208	
7/16"	5.88	.87	.24	.66	.30	20209	
1/2"	6.54	.98	.27	.75	.32	20210	
9/16"	7.13	1.14	.29	.84	.35	0920211	
5/8"	8.00	1.28	.32	.94	.39	0920212	
11/16"	8.81	1.39	.35	1.03	.42	0920213	
3/4"	9.67	1.50	.36	1.06	.45	20214	
13/16"	10.58	1.69	.37	1.18	.48	0920215	
7/8"	11.56	1.69	.38	1.28	.48	0920216	
15/16"	12.58	1.86	.39	1.37	.51	0920217	
1"	13.56	1.94	.42	1.47	.55	0920218	
1-1/16"	14.69	2.16	.44	1.61	.55	0920219	
1-1/8"	15.63	2.20	.48	1.65	.58	0920220	
1-1/4"	16.94	2.49	.51	1.82	.58	20222	
1-5/16"	18.31	2.52	.53	1.92	.62	20223	
1-3/8"	20.35	2.88	.78	2.16	.94	20224	
1-7/16"	20.35	2.88	.78	2.16	.94	20225	
1-1/2"	20.35	2.88	.78	2.16	.94	20226	
1-5/8"	24.08	3.44	.79	2.56	.98	20228	
1-11/16"	24.08	3.44	.79	2.56	.98	20229	
1-3/4"	26.09	3.70	.83	2.75	1.01	20230	
1-13/16"	26.09	3.70	.83	2.75	1.01	20231	
1-7/8"	27.10	3.88	.86	2.94	1.04	20232	
2"	28.75	4.88	.88	3.50	1.31	20234	
2-1/16"	28.75	4.88	.88	3.50	1.31	20235	
2-1/8"	28.75	4.88	.88	3.50	1.31	20236	
2-3/16"	28.75	4.88	.88	3.50	1.31	20237	
2-1/4"	28.75	4.88	.88	3.50	1.31	20238	
2-3/8"	28.75	4.88	.88	3.50	1.31	20239	
2-1/2"	28.75	4.88	.88	3.50	1.31	20240	

12 PT. METRIC COMBINATION WRENCHES							
Size mm	Dimensions (Inch)					Order No.	Price
	A	B	C	D	E		
7	4.24	.53	.19	.44	.23	20307	
8	4.38	.72	.20	.47	.25	20308	
9	4.91	.70	.20	.52	.26	20309	
10	5.55	.81	.22	.62	.29	20310	
11	5.88	.87	.24	.66	.30	20311	
12	6.27	.94	.25	.72	.32	20312	
13	6.54	.98	.27	.75	.32	20313	
14	7.13	1.14	.29	.84	.35	20314	
15	7.59	1.20	.30	.90	.37	20315	
16	8.00	1.28	.32	.94	.39	20316	
17	8.45	1.36	.33	.99	.40	20317	
18	8.81	1.39	.35	1.03	.42	20318	
19	9.67	1.50	.36	1.06	.45	20319	
20	10.30	1.56	.36	1.13	.46	20320	
21	10.95	1.63	.37	1.21	.47	20321	
22	11.56	1.69	.38	1.28	.48	20322	
23	12.20	1.78	.38	1.33	.50	20323	
24	12.80	1.86	.39	1.38	.51	20324	
25	13.56	1.94	.42	1.47	.55	20325	
26	14.12	2.16	.44	1.61	.55	20326	
27	14.69	2.16	.44	1.61	.55	20327	
28	15.25	2.20	.48	1.65	.58	20328	
29	15.37	2.43	.52	1.78	.58	20329	
30	16.30	2.43	.52	1.78	.58	20330	
32	16.94	2.49	.51	1.82	.58	20332	



WRENCHES
SERIES 903:



GEARED HEAD BOX



- **Access** : The small head design of the Geared Box Wrench allows access into tight areas and the 72 teeth ratcheting action allows the wrench to be turned easily while working in those tight areas. This is a combination guaranteed to make your job easier.
- **Speed** : The short ratcheting arc allows the fastener to be turned in confined areas, which helps you get your work done quickly.
- **Strength** : When you need to break loose tough fasteners or really tighten down a nut, the traditional box end - with its lobular design - keeps the wrench from slipping. And the long pattern forging gives you the extra leverage you need.

- **Made in the U.S.A.**: The geared box Wrench has All Steel Construction and is forged and heat treated in the USA using high alloy, domestically produced steel.
- **Safety** : The one piece design of the Geared Box Wrench won't split apart like a traditional ratcheting box wrench and the closed head design keeps out dirt and debris.
- **All Steel Construction** : The Geared Box Wrench includes a precision machined steel insert ring.
- **Lifetime Warranty** : If any Armstrong tool ever fails to give complete satisfaction, return it to your Armstrong Distributor and it will be repaired or replaced free of charge.

Individual Sizes

Size	Order No.	Price	Size	Order No.	Price
3/8"	0027510		10mm	9954510	
7/16"	0027511		11mm	9954511	
1/2"	0027512		12mm	9954512	
9/16"	0027513		13mm	9954513	
5/8"	0027514		14mm	9954514	
11/16"	0027515		15mm	9954515	
3/4"	0027516		16mm	9954516	
			17mm	9954517	
			18mm	9954518	
			19mm	9954519	

Sets (Supplied in vinyl roll)

Description	Order No.	Price
7 pc. Fractional: 3/8", 7/16, 1/2", 9/16", 5/8", 11/16", 3/4"	0027609	
10 Pc. Metric: 10mm, 11mm, 12mm, 13mm, 14mm, 15mm, 16mm, 17mm, 18mm, 19mm	9954609	
17 Pc. Combination Fractional/Metric: 3/8", 7/16", 1/2", 9/16, 5/8", 11/16", 3/4" 10mm, 11mm, 12mm, 13mm, 14mm, 15mm, 16mm, 17mm, 18mm, 19mm	0027708	

ADJUSTABLE FACE SPANNER

Order No.	Capacity Inches	Pin Specifications		Lgth Inches	Weight Lbs.	Price
		Extreme Diameter Inches	Height Inches			
34151	2	3/16	1/8	6-3/8	.32	
34154	3	1/4	3/16	8-1/4	.57	
34157	4	5/16	1/4	10-3/8	.99	



Pins forged integral with wrench and milled to exact sizes listed.

ADJUSTABLE HOOK SPANNER

Order No.	Capacity Range for Diameters Inches	Hook Specifications		Lgth Inches	Weight Lbs.	Price
		Thickness Inches	Depth Inches			
34301	3/4 - 2	11/32	1/8	6-3/8	.27	
34305	1-1/4 - 3	13/32	5/32	8-1/8	.53	
34307	2 - 4-3/4	15/32	3/16	11-3/8	1.06	
34310	4-1/2 - 6-1/4	15/32	1/4	12-1/8	1.23	
34313	6-1/8 - 8-3/4	15/32	5/16	13-3/4	1.36	



ADJUSTABLE PIN SPANNER

Order No.	Capacity Range for Diameters Inches	Hook Thickness Inches	Pin Specifications		Lgth Inches	Weight Lbs.	Price
			Dia. Inches	Height Inches			
34351	3/4 - 2	11/32	1/8	1/8	6-3/8	.27	
34354	3/4 - 2	11/32	3/16	5/32	6-3/8	.27	
34358	1-1/4 - 3	13/32	3/16	3/16	8-1/8	.53	
34361	1-1/4 - 3	13/32	1/4	7/32	8-1/8	.49	
34363	2 - 4-3/4	15/32	1/4	1/4	11-3/8	1.07	
34366	4-1/2 - 6-1/4	15/32	3/8	1/4	12-1/8	1.20	



Pins forged integral with wrench and milled to exact sizes listed.

BALL PEIN HAMMERS WOOD HANDLES



- Hardened and tempered on striking face
- Excellent wedging for longer life
- Faces polished
- Hammer perfectly balanced
- Seasoned wood handle

Size	Order No.	Price
1/16 lb.	4420219	
1/8 lb.	4420220	
1/4 lb.	4420221	
1/2 lb.	4420222	
3/4 lb.	4420223	
1 lb.	4420224	
1-1/2 lb.	4420225	
2 lb.	4420226	
3 lb.	4420227	

RUBBER MALLET - 16 oz



Non-mar smooth finish head of finest quality rubber. Smooth hardwood handle.

Order No. 2470000	Price	
-------------------	-------	--

DEAD-BLOW HAMMERS

- Made of extra durable polyurethane



STANDARD-HEAD

Face Dia.	Head Lgth	Weight	Order No.	Price
1-1/4"	3-1/8"	13 oz.	4420080	
1-3/4"	3-3/4"	21 oz.	4420148	
2"	4-1/8"	26 oz.	4420200	
2-1/4"	4-5/8"	45 oz.	4420216	
2-3/4"	5-3/8"	53 oz.	4420248	

INDUSTRIAL SUPPLIES

JEWELER'S SCREWDRIVERS SERIES 213:



High quality screwdrivers ideal for hobbyists, technicians, mechanics and do-it-yourselfers. Also used by jewelers, watchmakers, instrument makers, subminiature parts assemblers and model makers.



Four Bit Technician Screwdriver

- High quality screwdriver ideal for hobbyist, technician, mechanic and do-it-yourselfer.
- Four heat treated bits: Nos. 0 and 1 crosspoint, .125 and .100 straight blade.
- Bits store in handle.
- Knurled aluminum body with swivel head.
- Steel collet for greater strength.
- Overall size is 3/8" x 6-1/2".

Model No.	Order No.	Price
608	42561	

Jeweler's Screwdriver Set

- Nickel plated blade sizes: .100", .080", .070", .055", .040", .025".
- Screw chucks have identification rings showing blade size.
- Overall length 3-7/8".
- Conforms to government specifications GGG-S-1808.
- Plastic case.



Individual Screwdrivers

Model No.	Blade Width	Order No.	Price
600-0	.100	42515	
600-1	.080	42518	
600-2	.070	42521	
600-3	.055	42524	
600-4	.040	42527	
600-5	.025	42530	

Set of Six

Model No.	Order No.	Price
SPC600	42568	

JEWELER'S SCREWDRIVERS STARRETT SERIES 555:



- Screwdrivers are made for relatively small and delicate work.
- Bodies are made from steel, nicely knurled and are either nickel or chrome plated.
- Blades are replaceable and are made from the best quality steel, properly tempered and nickel plated.
- The swivel knobs are concave to fit the finger and are hexagonal in shape to prevent rolling when laid down.
- When not in use, blades can be reversed into the screwdriver body.
- Furnished in vinyl case.
- Approximate length 3-3/4"(95mm)

Blade Width- Inch(mm)	Catalog No.	EDP No.	Price
.025"(0.6mm)	555AA	52549	
.040"(1mm)	555A	52550	
.055"(1.4mm)	555B	52551	
.070"(1.8mm)	555C	52552	
.080"(2mm)	555D	52553	
.100"(2.5mm)	555E	52554	
#0 Phillips	555F	52561	

SETS

Description	Catalog No.	EDP No.	Price
Set of 6 - Nos. 555AA, A, B, C, D, E	S555Z-6	52564	
Set of 7 - Nos. 555AA, A, B, C, D, E, F	S555Z-7	52566	



SCREWDRIVERS

SERIES 802:



PRECISION SCREWDRIVERS

Precision screwdrivers have a tapered handle that allows rapid rotation. Precision handle, high quality plastic. Rotating cap for precise turning and control with fingertip. Blade CVM steel, hardened, chrome-plated. Precision ground tips for exact fit. Vapor chromed non-slip surface.

Order No.	Description	Price	
26190	7 pc. Slotted/Phillips Set Slotted sizes: 1.5, 2.0, 2.5, 3.0mm Phillips sizes: 00,0,1		
26390	7 pc. Hex driver metric Hex metric sizes: 0.7, 0.9, 1.3, 1.5, 2.0, 2.5, 3.0mm		
26391	8 pc. Hex driver inch Hex inch sizes: .028, .035, .050, 1/16, 5/64, 3/32, 7/64, 1/8"		
26790	6 pc. Torx® Set Torx® sizes: T6, T7, T8, T9, T10, T15		
26008	SL 1/32" (.80mm) x 1.6" (40mm)	SLOTTED	
26010	SL .039" (1.0mm) x 1.6" (40mm)		
26012	SL 3/64" (1.2mm) x 1.6" (40mm)		
26015	SL 1/16" (1.5mm) x 1.6" (40mm)		
26018	SL .070" (1.8mm) x 1.6" (40mm)		
26020	SL 5/64" (2.0mm) x 1.6" (40mm)		
26022	SL 5/64" (2.0mm) x 2" (50mm)		
26023	SL 5/64" (2.0mm) x 4" (100mm)		
26025	SL 3/32" (2.5mm) x 2" (50mm)		
26027	SL 3/32" (2.5mm) x 4" (100mm)		
26030	SL 1/8" (3.0mm) x 2" (50mm)		
26032	SL 1/8" (3.0mm) x 2.4" (60mm)		
26033	SL 1/8" (3.0mm) x 4" (100mm)		
26034	SL 1/8" (3.0mm) x 6" (150mm)		
26035	SL 9/64" (3.5mm) x 2.4" (60mm)		
26040	SL 5/32" (4.0mm) x 2.4" (60mm)		
26041	SL 5/32" (4.0mm) x 4" (100mm)		
26042	SL 5/32" (4.0mm) x 6" (150mm)		
26100	PH 00 x 1.6" (40mm)		PHILLIPS
26102	PH 000 x 1.6" (40mm)		
26105	PH 0 x 2" (50mm)		
26108	PH 0 x 3" (75mm)		
26110	PH 1 x 2.4" (60mm)		
26113	PH 1 x 3.1" (80mm)		
9926115	PH 1 x 6" (150mm)		
26307	Hex .028" (0.7mm) x 1.6" (40mm)	HEX	
26309	Hex .035" (0.9mm) x 1.6" (40mm)		
26313	Hex .050" (1.27mm) x 1.6" (40mm)		
26316	Hex 1/16" x 2" (50mm)		
26320	Hex 5/64" (2.0mm) x 2" (50mm)		
26323	Hex 3/32" x 2.4" (60mm)		
26327	Hex 7/64" x 2.4" (60mm)		
26331	Hex 1/8" x 2.4" (60mm)		
26703	TX T3 x 1.6" (40mm)		TORX
26704	TX T4 x 1.6" (40mm)		
26705	TX T5 x 1.6" (40mm)		
26706	TX T6 x 1.6" (40mm)		
26707	TX T7 x 1.6" (40mm)		
26708	TX T8 x 1.6" (40mm)		
26709	TX T9 x 2" (50mm)		
26710	TX T10 x 2" (50mm)		
26715	TX T15 x 2.4" (60mm)		
26720	TX T20 x 2.4" (60mm)		



SOFTFINISH SCREWDRIVERS

Wiha SoftFinish Slotted/Phillips screwdrivers have ergonomic cushion grip handles, multicomponent. Round blade, high alloy CVM steel, hardened, chrome-plated. *Set includes: Slotted sizes: 3.0, 4.0, 6.5mm Phillips sizes: 1, 2



Order No.	Description	Price
30295	5 pc. Slotted/Phillips Set*	
30205	SL 1/8" (3.0mm) x 4" (100mm)	SLOTTED
30210	SL 9/64" (3.5mm) x 4" (100mm)	
9930215	SL 5/32" (4.0mm) x 4" (100mm)	
30217	SL 5/32" (4.0mm) x 6" (150mm)	
30220	SL 7/32" (5.5mm) x 5" (125mm)	
30223	SL 1/4" (6.5mm) x 4" (100mm)	
30225	SL 1/4" (6.5mm) x 6" (150mm)	
9930227	SL 5/16" (8.0mm) x 6" (150mm)	
30230	SL 5/16" (8.0mm) x 7" (175mm)	
30235	SL 3/8" (10.0mm) x 8" (200mm)	
31105	PH 0 x 2.4" (60mm)	PHILLIPS
31110	PH 1 x 3.1" (80mm)	
31112	PH 1 x 8" (200mm)	
31114	PH 1 x 12" (300mm)	
31115	PH 2 x 4" (100mm)	
31117	PH 2 x 8" (200mm)	
31118	PH 2 x 12" (300mm)	
31120	PH 3 x 6" (150mm)	

MICROFINISH SCREWDRIVERS

Wiha MicroFinish Slotted/Phillips screwdrivers have ergonomic nonslip grip handles, cellulose-acetate, impact resistant. Blade high alloy CVM steel, hardened, chrome-plated. Exact fit precision ground tips. *Set includes: Slotted sizes: 4.0, 5.5, 8.0mm. Phillips sizes: 1,2



Order No.	Description	Price	
52090	5 pc. Slotted/Phillips Set*		
9952005	SL 5/32" (4.0mm) x 4" (100mm)	SLOTTED	
9952010	SL 5/32" (4.0mm) x 6" (150mm)		
9952020	SL 7/32" (5.5mm) x 5" (125mm)		
52025	SL 7/32" (5.5mm) x 6" (150mm)		
52035	SL 1/4" (6.5mm) x 6" (150mm)		
9952040	SL 5/16" (8.0mm) x 6" (150mm)		
52050	SL 3/8" (10.0mm) x 8" (200mm)		
52105	PH 1" x 3.1" (80mm)		PHILLIPS
9952110	PH 1" x 8" (200mm)		
9952115	PH 2" x 4" (100mm)		
9952120	PH 2" x 8" (200mm)		
52125	PH 3" x 6" (150mm)		

MULTI-BIT SCREWDRIVER SET

Wiha PowerHandle, cellulose-acetate, impact resistant. Snap lock rotatable cap. Chambered bit holder equipped with transparent selector and 6 bits. Shaft CVM steel, hardened, chrome-plated. 1/4" bit holder, stainless steel. Slotted sizes include: 5.5, 6.5, 8.0mm Phillips sizes include: 1, 2, 3



Order No.	Description	Price
38006	6 pc. Slotted/Phillips Set	

While we show only the popular items we can supply their entire range of products; please inquire.



Made in U.S.A. OR OTHER FINE BRANDS



Made in U.S.A.

INDUSTRIAL SUPPLIES

8 PIECE-SCREWDRIVER SET IN STORAGE TRAY

Order No. 30847

Price

Size/Length	Description
3/16" x 3"	Cabinet Tip - Slotted
#1 x 3"	Phillips Tip
#2 x 4"	Phillips Tip
#3 x 6"	Phillips Tip
1/4" x 4"	Round Blade - Slotted
5/16" x 6"	Round Blade - Slotted
1/4" x 1-1/2"	Slotted Stubby
#2 x 1-1/2"	Phillips Stubby



SLOTTED STUBBY SCREWDRIVER



Description	Overall Length	Order No.	Price
1/4" x 1-1/2"	3-1/2"	30844	<input type="text"/>

PHILLIPS STUBBY SCREWDRIVER



Description	Overall Length	Order No.	Price
#2 x 1-1/2"	3-1/2"	30845	<input type="text"/>

7 PIECE - METRIC SOLID SHAFT NUT DRIVER SET IN POUCH

Order No: 30821

Price



Size (mm)	Description	Order No.	Price
5	Nut Driver 5mm	30854	<input type="text"/>
6	Nut Driver 6mm	30856	
7	Nut Driver 7mm	30857	
8	Nut Driver 8mm	30858	
9	Nut Driver 9mm	30859	
10	Nut Driver 10mm	30860	
11	Nut Driver 11mm	30861	

CABINET TIP SLOTTED SCREWDRIVER



Description	Overall Length	Order No.	Price
3/16" x 3"	5-3/4"	30833	<input type="text"/>
3/16" x 6"	9-1/2"	30834	

PHILLIPS TIP SCREWDRIVER



Description	Overall Length	Order No.	Price
#0 X 2-1/2" w/clip	4-3/8"	30835	<input type="text"/>
#1 X 3"	6-1/2"	30836	
#2 X 4"	7-1/2"	30837	
#3 X 6"	9-1/2"	30838	

ROUND BLADE SLOTTED SCREWDRIVER



Description	Overall Length	Order No.	Price
1/4" x 4"	8-1/4"	30839	<input type="text"/>
1/4" x 6"	10-1/4"	30840	
5/16" x 6"	10-3/4"	30841	

SQUARE BLADE SLOTTED SCREWDRIVER



Description	Overall Length	Order No.	Price
5/16" x 6"	10-3/4"	30842	<input type="text"/>
3/8" x 8"	13"	30843	

7 PIECE - SOLID SHAFT NUT DRIVER SET IN POUCH

Order No. 30820

Price



Size	Description	Order No.	Price
3/16"	Nut Driver 3/16"	30802	<input type="text"/>
1/4"	Nut Driver 1/4"	30804	
5/16"	Nut Driver 5/16"	30806	
11/32"	Nut Driver 11/32"	30807	
3/8"	Nut Driver 3/8"	30808	
7/16"	Nut Driver 7/16"	30809	
1/2"	Nut Driver 1/2"	30810	



While we show only the most popular ALLEN items we can supply their entire range of products; please inquire.



SCREWDRIVERS
SERIES 903:



STANDARD TIP, SQUARE SHANK



Tip Width x Blade Length	Overall Length	Order No.	Price
1/4 x 1-5/16"	3-1/16"	66541	
1/4 x 4	8-1/4	66544	
3/8 x 12	17-7/16	66546	
5/16 x 6	10-7/8	66547	
3/8 x 8	12-7/8	66550	
3/8 x 10	14-7/8	66553	

CABINET TIP, ROUND SHANK



Tip Width x Blade Length	Overall Length	Order No.	Price
3/16 x 3"	6-5/8"	66561	
3/16 x 4	7-3/4	66563	
3/16 x 6	8-5/8	66564	
3/16 x 8	11-5/8	66567	
3/16 x 10	13-5/8	66570	

STANDARD TIP, ROUND SHANK



Tip Width x Blade Length	Overall Length	Order No.	Price
3/16 x 3"	7-3/4"	66502	
1/4 x 4 (.037")*	8-29/32	66505	
1/4 x 4 (.040")*	8-1/4	66501	
5/16 x 6	10-7/8	66504	
3/8 x 10	15-7/16	66509	
3/8 x 12	17-7/16	66510	
3/8 x 8	12-7/8	66507	

*Tip Thickness

PHILLIPS TIP, ROUND SHANK



Tip Size X Blade Length	Overall Length	Order No.	Price
#2 x 1-5/16"	3-1/16"	66521	
#1 x 3	6-5/8	66524	
#2 x 4	8-1/4	66527	
#2 x 6	10-29/32	9966526	
#2 x 12	16-29/32	66528	
#3 x 6	10-7/8	66530	

8 PIECE SCREWDRIVER SET

Contains (5) Slotted, Round Shank and (3) Phillips sizes in vinyl roll.

CUSHION GRIP

Slotted	Phillips
1/4 x 4" (.040")*	1 x 3"
3/16 x 3	2 x 4"
5/16 x 6	3 x 6"
1/4 x 4 (.037")*	
3/8 x 8	

*Tip Thickness

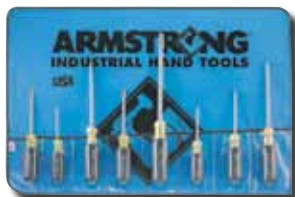

Order No. 66612	Price
-----------------	-------

MULTI-BIT SCREWDRIVER

SERIES 526:

This 5-in-ONE offers four different bits in one screwdriver plus a nut driver. The bits reverse in the tube and the tube reverses in the handle. There is a 1/4" & 3/16" slotted bit and a #1 & #2 phillips bit. The chrome/nickel plated tube is a hex tube to create a 5/16" nut driver on either end. The handle has a wide diameter for a better, more comfortable grip.



Order No. 22000	Price
-----------------	-------

DEAD-BLOW HAMMERS

SERIES 855:

- One-piece construction
- No exposed metal on handles or heads
- No mark, no spark, complete protection and safety for machinery, product and worker
- Trucothane™ is custom formulated to set a new standard for soft face performance and durability. Eliminates mushrooming, splitting, absorption of liquids, contamination and chip pickup in faces
- Outlasts rawhide, rubber, brass, lead, nylon and other plastic-type heads by 10-20 times
- Exclusive textured, nonslip, comfort contoured handle and safety flanged butt provide sure grip and reduce fatigue



STANDARD-HEAD

Face Dia.	Head Lgth	Weight	Order No.	Price
1-1/4"	3-1/8"	13 oz.	4249000	
1-3/4"	3-3/4"	21 oz.	4249011	
2-1/4"	4-1/8"	26 oz.	4249022	
2-3/4"	4-5/8"	45 oz.	4249033	
	5-3/8"	53 oz.	4249044	

SLIM-LINE

Face Dia.	Head Lgth	Weight	Order No.	Price
7/8"	2-7/8"	8 oz.	4239050	
1-1/4"	4-3/16"	18 oz.	4239061	
1-1/2"	4-1/4"	22 oz.	4239072	
1-3/4"	5-3/16"	26 oz.	4239083	

RAWHIDE MALLET

SERIES 416:

Garland's all-rawhide mallets are made of tough, long-wearing, water buffalo rawhide. They're ideal for use on broad-faced striking surfaces in a broad range of applications.



Face Dia.	Weight	Order No.	Price
1"	2 oz.	4211000	
1-1/4"	4 oz.	4211001	
1-1/2"	6 oz.	4211002	
1-3/4"	9 oz.	4211003	
2"	11 oz.	4211004	
2-3/4"	22 oz.	4211005	
2-3/4"	24 oz.	4211006	



SPLIT-HEAD HAMMERS

SERIES 416:

The split-head hammer does the work of two different hammers because the faces can be easily changed. Two face types are available: rawhide and nylon. Specify face type when ordering.



Hammer with Rawhide Faces

Face Dia.	Weight	Order No.	Price
1-1/4"	1-1/2 lbs	4431001	
1-1/2"	2 lbs	4431002	
1-3/4"	2-3/4 lbs	4431003	
2"	4 lbs	4431004	
2-3/4"	6-1/2 lbs.	4431005	



Hammer Faces

Face Dia.	Rawhide Order No.	Price/Pair	Nylon Order No.	Price/Pair
1-1/4"	4221001		4222001	
1-1/2"	4221002		4222002	
1-3/4"	4221003		4222003	
2"	4221004		4222004	
2-3/4"	4221005		4222005	

BRASS HAMMERS

SERIES 855:

- Non-sparking
- Will not mar finished iron or steel surfaces
- Premium hickory handle



Approx. Wt. (lb.)	Face Dia.	Handle Lgt.	Order No.	Price
1/2	1"	12"	8550701	
1	1-1/8"	12"	8550702	
1-1/2	1-3/8"	13"	8550703	
2	1-3/8"	13"	8550704	
3	1-1/2"	14"	8550705	
4	1-5/8"	16"	8550706	
5	1-3/4"	16"	8550707	
6	1-3/4"	16"	8550708	
10	2"	26"	8550709	

LEAD HAMMERS

SERIES 855:

- Lead alloy provides the softest blow
- Steel handle with ergonomic shur-grips
- Excellent dead-blow hammer



Approx. Wt. (lb.)	Face Dia.	Handle Lgt.	Order No.	Price
1	3/4"	9"	9550113	
2	1-3/16"	9"	9550114	
3	1-5/8"	9-1/2"	9550115	
4	1-9/16"	9-1/2"	9550116	
5	1-5/8"	9-1/2"	9550117	
11	2"	26"	9550123	

NO-MAR HAMMERS WITH REPLACEABLE POLYURETHANE PRESS-ON TIPS

Head Dia.	Head Length	Handle Length	Approx. Weight	Fiberglass Handle		Wood Handle		(Repl't)-Tips	
				Order No.	Price	Order No.	Price	Order No.	Price
5/8"	2-1/4"	8"	3-3/4 oz.	2021700		2020700		2027001	
3/4"	2-1/2"	10"	4-1/2 oz.	2021701		2020701		2027011	
1"	3-1/4"	11"	1/2 lb.	2021705		2020705		2027051	
1-1/4"	3-3/4"	13"	3/4 lb.	2021707		2020707		2027071	
1-1/2"	4"	13"	1-1/4 lb.	2021717		2020717		2027171	

HAMMERS

SERIES 202:



NO-MAR HAMMERS WITH SCREW ON TIPS

Aluminum Head



Head Dia.	Head Length	Handle Length	Handle Type	Order No.	Price
1"	3-1/2"	11"	Wood	2021770	
1"	3-1/2"	11"	Fiberglass	2020770	
1-1/2"	4-1/2"	12"	Wood	2021772	
1-1/2"	4-1/2"	12"	Fiberglass	2020772	
2"	5"	13"	Wood	2021774	
2"	5"	13"	Fiberglass	2020774	

Screw on Tips

Hammers come with green and red tips

Color	1"		1-1/2"		2"	
	Order No.	Price	Order No.	Price	Order No.	Price
Green (Tough)	2027711		2027731		2027751	
Red (Medium)	2027712		2027732		2027752	
Brown (Soft)	2027713		2027733		2027753	
Cream (Med. Hard)	2027714		2027734		2027754	
Black (Hard)	2027715		2027735		2027755	

NO-MAR COPPER AND BRASS HAMMERS

With Fiberglass Handles

- Non spark
- Non magnetic



Face Dia.	Weight	Brass Order No.	Price	Copper Order No.	Price
7/8"	8 oz.	2020750		2020760	
1"	1 lb.	2020751		2020761	
1-1/4"	1-1/2 lb	2027515		2027615	
1-1/4"	2 lb	2020752		2020762	
1-1/2"	3 lb	2020753		2020763	

NO-MAR LEAD HAMMERS

STEEL HANDLES WITH VINYL GRIPS



Face Dia.	Head Length	Weight	Handle Length	Order No.	Price
3/4"	2-5/8"	1 lb	9"	2020731	
1-1/8"	2-5/8"	2 lb	10"	2020732	
1-9/16"	3-1/8"	3 lb	10"	2020733	
1-5/8"	3-3/4"	5 lb	10"	2020735	



HAND TOOLS
SERIES 871



BALL PEIN - WOOD HANDLE HAMMERS



Head Weight	Length	Order No.	Price
2 oz	10"	25700	
4 oz	10-1/4"	25701	
8 oz	12-1/4"	25702	
12 oz	13-1/2"	25703	
16 oz	14-1/4"	25704	
20 oz	14-1/2"	25705	
24 oz	15-1/2"	25706	
32 oz	16"	25707	
40 oz	16"	25708	
48 oz	16"	25709	

LINESMAN PLIERS



Length	Order No.	Price
8.00	25208	

CHAIN NOSE PLIERS WITH CUTTER



Length	Order No.	Price
6.50	25206	
8.00	25608	

HEAVY DUTY DIAGONAL CUTTING PLIERS



Length	Order No.	Price
7.00	25207	

DIAGONAL CUTTING PLIERS



Length	Order No.	Price
5.00	25404	
6.00	25406	
7.00	25407	



While we show only the most popular items we can supply their entire range of products; please inquire.



SOFT FACE HAMMER

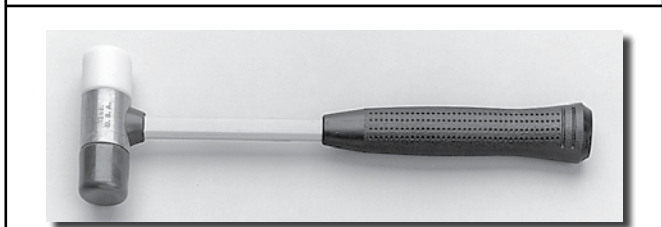

Head Weight	Length	Order No.	Price
12 oz	11-5/8"	25716	

RUBBER MALLET HAMMERS



Head Weight	Length	Order No.	Price
20 oz	13-1/2"	25714	
28 oz	16-1/2"	25715	

ADJUSTABLE WRENCHES



Length	Order No.	Price	Length	Order No.	Price
4.00	24004		12.00	24012	
6.00	24006		15.00	24015	
8.00	24008		18.00	24017	
10.00	24010		24.00	24024	

SLIP JOINT PLIERS



Overall Length	Order No.	Price
6.00	25106	
8.00	25108	

RIB LOCK - CHROME FINISH PLIERS



Length	Order No.	Price
10.00	25310	
16.00	25316	

INDUSTRIAL SUPPLIES



PROTO
OR OTHER FINE BRANDS



Made in U.S.A.

TONGUE & GROOVE PLIERS



Features:

- Patented Perma Lock fastener.
- Polished steel.

Size	Capacity	Model No.	Order No.	Price
4-1/2	1/2	424	0880424	
6-1/2	7/8	426	0880426	
9-1/2	1-1/2	420	0880420	
10	2	430	0880430	
12	2-1/4	440	0880440	

DIAGONAL CUTTING PLIERS



Features:

- Polished steel finish.
- Perfectly mated cutting edges.

Size	Model No.	Order No.	Price
7	337	0880337	
7-3/4	447	0880447	

NUTBUSTER PLIER

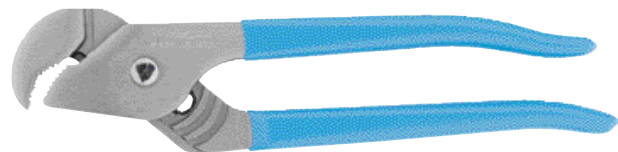

Features:

- Right angle teeth grip in all directions.
- Double Tongue and Groove - won't slip.

Size	Model No.	Order No.	Price
9-1/2	410	0880410	

LONG NOSE PLIERS

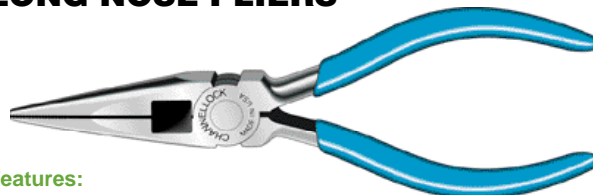

Features:

- Polished steel finish.
- Hand honed.
- Side cutter

Size	Model No.	Order No.	Price
6	326	0880326	
7-1/2	317	0880317	

LINEMEN'S PLIERS

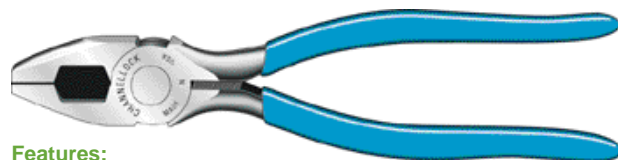

Features:

- Polished steel finish.
- Perfectly mated cutter.
- Rounded nose.

Size	Model No.	Order No.	Price
8-1/2	348	0880348	
9"	369	0880369	

*High Leverage

WIRING TOOL



Features:

- Crimps both insulated and non-insulated wire.
- Strips wire without damaging the conductor.

Size	Model No.	Order No.	Price
8	908	0880908	



While we show only the most popular **CHANNEL LOCK** items we can supply their entire range of products; please inquire.



LOCKING PLIERS

Series 927:



- High Grade alloy steel scientifically hardened & tempered.
- Nickel plated finish.
- Exerts more than a ton of pressure between jaws.
- Adjustable to ratchet-like action.

STRAIGHT JAWS

REGULAR MODEL
WITHOUT WIRE CUTTER



Length	Jaw Thick	Jaw Adjusts	Model No.	Order No.	Price
7	5/16	1-1/8	7R	9270007	
10	5/8	1-5/8	10R	9270010	

CURVED JAWS

THIN NOSE
WITH WIRE CUTTER



Length	Jaw Thick	Jaw Adjusts	Model No.	Order No.	Price
4	1/4	15/16	4WR	9271104	
5	1/4	1-1/4	5WR	9271105	
7	5/16	1-5/8	7WR	9271107	
10	3/8	1-7/8	10WR	9271110	

CURVED JAWS

THIN NOSE
WITHOUT WIRE CUTTER



Length	Jaw Thick	Jaw Adjusts	Model No.	Order No.	Price
7	5/16	1-5/8	7CR	9270107	
10	3/8	1-7/8	10CR	9270110	

20R LOCKING CHAIN CLAMP

Holds and locks around any shape, any size. Adjusts quickly for ratchet action in either direction.



- Size: 9"
- Effective Chain Length: 18"

Order No. 9270020	Price	
-------------------	-------	--

LOCKING SHEET METAL TOOL

FOR BENDING,
FORMING & CRIMPING

Locks to work with powerful grip. Makes all kinds of bending, forming, crimping jobs easier and faster.



Length	Jaw Width	Throat Depth	Model No.	Order No.	Price
8	3-1/8	1-3/4	8R	9270008	

"C" CLAMPS WITH EASY RELEASE

FEATURES:

- Made of special alloy steel, hardened and tempered.
- Bright finish.
- Adjusts by means of end screw then locks onto work by a squeeze of the hand. User can hold work with one hand and apply clamp with the other.
- Small jaw area for close quarters. Quick application for repeat jobs. Easy release lever in handle.



Length	Jaw Adjusts	Weight	Model No.	Order No.	Price
6	0-2	7-1/2 oz	6R	9273106	
11	0-4	28 oz	11R	9273111	
18	0-8	40 oz	18R	9273118	

LOCKING WELDING CLAMP

DEEP THROATED,
U-SHAPED JAWS

Deep-throated, U-shaped jaws for visibility and working space. Holds work in proper alignment.



Length	Jaw Width	Throat Depth	Model No.	Order No.	Price
9	2-3/4	1-5/8	9R	9270009	



While we show only the popular **VISE-GRIP** items we can supply their entire range of products; please inquire.



IRWIN

SNIPS
Series 929:

IRWIN



104



101



102



103



207



210



212

Size	Cutting Pattern	Maximum Cutting Capacity	Length of Cut	Type	Model No.	Order No.	Price
10"	Straight and curves	Sheet metal, vinyl, plastic, rubber and many other applications.	1-5 1/2"	Utility	21304	9290104	
10"	Left and straight	Up to .84mm/22ga. Stainless and 1.19mm/18ga. Mild Steel	1-5 1/16"	Aviation	2073111	9290101	
10"	Right and straight	Up to .84mm/22ga. Stainless and 1.19mm/18ga. Mild Steel	1-5 1/16"	Aviation	2073112	9290102	
10"	Straight and wide curves	Up to .84mm/22ga. Stainless and 1.19mm/18ga. Mild Steel	1-5 1/16"	Aviation	2073113	9290103	
7"	Tight curves and straight cuts	Up to .45mm/26ga. Cold Rolled Steel, .38mm/28 ga. Stainless Steel	1-1/2"	Tinner	23007	9290207	
10"	Tight curves and straight cuts	Up to .61mm/24ga. Cold Rolled Steel, .45mm/26 ga. Stainless Steel	2"	Tinner	23010	9290210	
12-3/4"	Tight curves and straight cuts	Up to .84mm/22ga. Cold Rolled Steel, .61mm/24 ga. Stainless Steel	2-3/4"	Tinner	23012	9290212	

AVIATION SNIPS
SERIES 442:



**#82 SAFETY NOSE
RETRACTABLE BLADE KNIFE**
SERIES 526:



Straight Cut Right Cut Left Cut



The LUTZ #82 is a heavy-duty industrial quality retractable utility knife. The specially built zinc retractor allows for smoother operation in all three cutting positions. The safety nose overlap on both the top and bottom of the knife is its prominent safety feature. The LUTZ #82 is furnished with three heavy duty .025 blades with additional storage in the handle.

Description	Order No.	Price
Straight Cut	2510000	
Right Cut	2510010	
Left Cut	2510020	
3-pc. set	4485418	

Blades of high alloy tool steel drop forged with serrated edges. Comfort grip contoured, color-coded vinyl handles. Compound leverage for extra cutting power. 9-3/4" long, cuts up to 18 gauge.

Order No. 30282 Price:

REPLACEMENT BLADES (PACK OF 5 BLADES)

Order No. 3000925 Price:

REPLACEMENT BLADES (PACK OF 100 BLADES)

Order No. 3000100 Price:



FASTENER DRIVE TOOLS

SERIES 843:



SHANK INSERT BITS (1/4" SHANK)

- Compact and versatile allowing them to be used as hand tool or power tool accessories

Phillips Insert Bits					
Point Size	Shank	OAL	Pkg. Qty	Order No.	Price
#0	1/4"	1"	25	4392001	
#1	1/4"	1"	25	4392005	
#2	1/4"	1"	25	4392011	
#3	1/4"	1"	25	4392019	
Phillips Drywall Insert Bits					
#2	1/4"	1"	25	4392047	



1/4" MAGNETIC HEX SHANK BIT HOLDERS

- Designed for use with insert bits only.



Description	OAL	Order No.	Price
Standard W/ C-Ring	2-1/4"	4393712	
No C-Ring	2-1/4"	4393714	
Knurled	2-15/16"	4393715	
Standard W/C-Ring	2-31/32"	4393718	
No C-Ring	2-31/32"	4393722	

MAGNETIC POWER NUTSETTERS-FRACTIONAL

POWER NUTSETTER:

- For use with sheet metal screws and other hexagon head fasteners.
- Standard 6pt. design.



Hex Drive	Shank Dia	Socket Body	Shank Body	OAL	Pkg. Qty	Order No.	Price
1/4"	1/4"	7/16"	-	1-7/8"	10	4394212	
5/16	1/4"	1/2"	-	1-7/8"	10	4394232	
3/8	1/4"	9/16"	-	1-7/8"	10	4394252	
7/16	1/4"	5/8"	-	1-7/8"	10	4394272	
1/4	1/4"	7/16"	5/16"	2-9/16"	10	4394312	
5/16	1/4"	1/2"	5/16"	2-9/16"	10	4394332	
7/16	1/4"	5/8"	3/8"	2-9/16"	10	4394372	
6mm	1/4"	11.1mm	-	47.6mm	10	4394202	
8	1/4"	12.7	-	47.6	10	4394204	
10	1/4"	14.3	-	47.6	10	4394206	

SQUARE DRIVE SOCKET ADAPTERS



- Pinlock design for production applications
- Ball retention design for quick change applications

Sq. drive	Lock Type	OAL	Order No.	Price
1/4"	PIN	2"	4393758	
1/4"	BALL	2"	4393761	
3/8"	PIN	1-5/8"	4393781	
3/8"	BALL	1-5/8"	4393782	
3/8"	PIN	2"	4393783	
3/8"	BALL	2"	4393784	
3/8"	PIN	3"	4393786	
3/8"	BALL	3"	4393787	
1/2"	BALL	2"	4393795	
1/2"	BALL	3"	4393797	

Square Recess Insert Bits					
Point Size	Shank	OAL	Pkg. Qty	Order No.	Price
#0	1/4"	1"	25	4392201	
#1	1/4"	1"	25	4392203	
#2	1/4"	1"	25	4392205	
#3	1/4"	1"	25	4392207	



Socket Head Insert Bits - Fractional					
Point Size	Shank	OAL	Pkg Qty	Order No.	Price
.050"	1/4"	1-1/4"	10	4392407	
1/16	1/4"	1-1/4"	10	4392403	
5/64	1/4"	1-1/4"	10	4392411	
3/32	1/4"	1-1/4"	10	4392415	
7/64	1/4"	1-1/4"	10	4392419	
1/8	1/4"	1-1/4"	10	4392423	
9/64	1/4"	1-1/4"	10	4392427	
5/32	1/4"	1-1/4"	10	4392431	
3/16	1/4"	1-1/4"	10	4392437	
7/32	1/4"	1-1/4"	10	4392443	
1/4	1/4"	1-1/4"	10	4392451	
5/16	1/4"	1-1/4"	10	4392467	
3/8	1/4"	1-1/4"	10	4392483	



Socket Head Insert Bits - Metric					
Point Size	Shank	OAL	Pkg Qty	Order No.	Price
2mm	1/4"	1-1/4"	10	4392507	
3mm	1/4"	1-1/4"	10	4392509	
4mm	1/4"	1-1/4"	10	4392511	
5mm	1/4"	1-1/4"	10	4392513	
6mm	1/4"	1-1/4"	10	4392515	
8mm	1/4"	1-1/4"	10	4392517	

Quality Hand Tools !

INDUSTRIAL SUPPLIES



SERIES 843:



- Designed for higher torque capabilities of power tools.
- Fit directly into the power drill chuck or quick change chuck adapter.

POWER BITS (1/4" SHANK)

SLOTTED POWER BITS



Point Size	Shank	OAL	Pkg. Qty	Order No.	Price
3-4	1/4"	1-15/16	10	4393103	
4-5	1/4	1-15/16	10	4393105	
5-6	1/4	1-15/16	10	4393107	
6-8	1/4	1-15/16	10	4393109	
8-10	1/4	1-15/16	10	4393111	
10-12	1/4	1-15/16	10	4393113	
12-14	1/4	1-15/16	10	4393115	
3-4	1/4	2-3/4	10	4393123	
4-5	1/4	2-3/4	10	4393125	
5-6	1/4	2-3/4	10	4393127	
6-8	1/4	2-3/4	10	4393129	
8-10	1/4	2-3/4	10	4393131	
10-12	1/4	2-3/4	10	4393133	
12-14	1/4	2-3/4	10	4393135	
3-4	1/4	3-1/2	10	4393155	
4-5	1/4	3-1/2	10	4393157	
5-6	1/4	3-1/2	10	4393159	
6-8	1/4	3-1/2	10	4393161	
8-10	1/4	3-1/2	10	4393163	
10-12	1/4	3-1/2	10	4393165	
12-14	1/4	3-1/2	10	4393167	
3-4	1/4	6	5	4393173	
4-5	1/4	6	5	4393175	
5-6	1/4	6	5	4393177	
6-8	1/4	6	5	4393179	
8-10	1/4	6	5	4393181	
10-12	1/4	6	5	4393183	
12-14	1/4	6	5	4393185	

SLOTTED POWER BITS WITH FINDER



Point Size	Shank	OAL	Pkg. Qty	Order No.	Price
5-6	1/4"	2-5/32"	10	4393191	
6-8	1/4"	2-5/32"	10	4393193	
10-12	1/4"	2-5/32"	10	4393195	

SQUARE RECESS POWER BITS



Size	Shank	OAL	Pkg. Qty	Order No.	Price
#1	1/4"	1-15/16	10	4393203	
#2	1/4	1-15/16	10	4393205	
#3	1/4	1-15/16	10	4393207	
#1	1/4	2-3/4	10	4393211	
#2	1/4	2-3/4	10	4393213	
#3	1/4	2-3/4	10	4393215	
#1	1/4	6	10	4393230	
#2	1/4	6	10	4393231	
#3	1/4	6	10	4393232	

TORX® POWER BITS



Common in automotive and computer industries

Point Size	Shank	Overall Length	Order No.	Price
T6	1/4"	1-15/16"	4393306	
T7	1/4"	1-15/16"	4393309	
T8	1/4"	1-15/16"	4393312	
T9	1/4"	1-15/16"	4393315	
T10	1/4"	1-15/16"	4393318	
T15	1/4"	1-15/16"	4393321	
T20	1/4"	1-15/16"	4393324	
T25	1/4"	1-15/16"	4393327	
T27	1/4"	1-15/16"	4393330	
T30	1/4"	1-15/16"	4393333	
T40	1/4"	1-15/16"	4393336	

PHILLIPS POWER BITS



Size	Shank	OAL	Pkg. Qty	Order No.	Price
#1	1/4"	1-15/16	10	4393003	
#2	1/4	1-15/16	10	4393007	
#3	1/4	1-15/16	10	4393011	
#1	1/4	2-3/4	10	4393017	
#2	1/4	2-3/4	10	4393019	
#3	1/4	2-3/4	10	4393021	
#1	1/4	3	10	4393043	
#2	1/4	3	10	4393047	
#3	1/4	3	10	4393049	
#1	1/4	3-1/2	10	4393023	
#2	1/4	3-1/2	10	4393025	
#3	1/4	3-1/2	10	4393029	
#1	1/4	4	10	4393053	
#2	1/4	4	10	4393057	
#3	1/4	4	10	4393059	
#1	1/4	6	10	4393063	
#2	1/4	6	10	4393067	
#3	1/4	6	10	4393069	



While we show only the popular **HANSON.** items we can supply their entire range of products; please inquire.

**BALLDRIVER®
POWER BITS**
SERIES 805:



- For power tools having a 1/4" hex adapter.



Hex	Blade Length	Order No.	Price
Inch Sizes			
5/64"	3.0"	10804	
3/32"	3.0"	10805	
7/64"	3.0"	10806	
1/8"	3.0"	10807	
9/64"	3.0"	10808	
5/32"	3.0"	10809	
3/16"	3.0"	9910810	
7/32"	3.0"	10811	
1/4"	3.0"	9910812	
5/16"	3.0"	9910813	
3/8"	3.0"	9910814	
1/2"	3.0"	9910816	
Metric Sizes			
2mm	76mm	0910852	
2.5mm	76mm	9910854	
3mm	76mm	0910856	
4mm	76mm	9910860	
5mm	76mm	9910864	
6mm	76mm	9910868	
8mm	76mm	9910872	
10mm	76mm	9910876	
12mm	76mm	0910880	

**DRILL-OUT®
BROKEN BOLT
EXTRACTORS**
SERIES 967:



FEATURES:

- Removes broken bolts and studs without damaging the hole threads.
- Designed to be used in 3/8" variable speed electric drill.
- Remove broken bolts in a fraction of the time used by manual tools.
- Patented design drill point with self-centering, left cutting drill point, gives the user control and maneuverability while drilling.
- Drill bit and extractor in one tool.
- Sets supplied in plastic case.

Power Extractors

Size of Bolt or Stud to be removed	Order No.	Price
1/4" (6mm)	9670016	
5/16" (8mm)	9670020	
3/8" (10mm)	9670024	
1/2" (12mm)	9670032	
4 Piece Set 1/4"-1/2" (6mm-12mm)	9670401	

Micro Power Extractors

Size of Bolt or Stud to be removed	Order No.	Price
#5 & #6 (3mm)	9670003	
#8 (4mm)	9670004	
#10 & 12 (5mm)	9670005	
1/4" (6mm)	9670006	
4 Piece Set #5-1/4" (3mm-6mm)	9670450	

Master Extractor Set

Size of Bolt or Stud to be removed	Order No.	Price
7 Piece Set 1/8" (#5) - 1/2" & 3mm-12mm	9670701	

BIT-SELECTORS
SERIES 802:

Compact size and easy bit selection make this bit-selector an ideal maintenance tool. 10 hardened bits of CVM steel, hardened, chrome-plated. 1/4" magnetic bit holder can be used in power tools.



Order No.	Description	Price
79243	Slotted, Phillips, Torx® Bit-Selector Slotted: 5.5, 6.5, 8.0mm; Phillips: 0, 1, 2, 3 Torx®: T10, T15, T20	
79245	Torx® Bit-Selector Torx® T7, T8, T9, T10, T15, T20, T25, T27, T30, T40	

TOPRA RATCHET SETS
SERIES 802:

WIHA Topra Ratchet handle, ergonomic design for free runner mechanism. Topra Ratchet handle has four advantages: screwdriver, ratchet, reversible tool and bit holder in one tool. Blades are high alloy CVM steel, hardened, and chrome-plated which allow maximum protection against corrosion.



Order No.	Description	Price
28295	10 Torx® Set Sizes: T7, T8, T9, T10, T15, T20, T25, T27, T30, T40	
28296	10 Slotted/Phillips/Torx® Set: Slotted 5.5, 6.5, 8.0mm Phillips: 0, 1, 2, 3, Torx®: T10, T15, T20	

MIDGET RATCHET SETS
SERIES 960:

STANDARD KIT "THE MOST POPULAR SET"

- 1 Midget Ratchet
- 1 Extension
- 1 Screw Driver Handle
- 12 Allen Hex Type Adapters. (.050, 5/64, 7/64, 9/64, 3/16, 1/4, 1/16, 3/32, 1/8, 5/32, 7/32, 5/16.)
- 2 Slotted Head Adapters 1/4, 3/8.
- 2 Phillips Head Adapters #1, #2.
- 1 pc 1/4 Square Drive Adapter.
- Polyethylene case 4-1/2" x 6-1/2".

Model # 4320

Order No. 9604320	Price	
-------------------	-------	--



STANDARD ASSORTMENT PLUS METRIC

- 1 Midget Ratchet
- 1 Extension
- 1 Screw Driver Handle
- 12 Allen Hex Type Adapters (.050, 5/64, 7/64, 9/64, 3/16, 1/4, 1/16, 3/32, 1/8, 5/32, 7/32, 5/16)
- 3 Slotted Head Adapters 3/16, 1/4, 3/8
- 2 Phillips Head Adapters #1, #2
- 1 pc 1/4 Square Drive Adapter
- 7 Metric (Allen Hex Type) Adapters: 1.5mm, 2.0mm, 2.5mm, 3.0mm, 4.0mm, 5.0mm, 6.0mm, (Size indicates distance across flats)
- Polyethylene Case 5-1/2" x 7-3/4"

Model # 7331

Order No. 9607331	Price	
-------------------	-------	--



INDUSTRIAL SUPPLIES



Metrics available; please inquire.

1/4" DRIVE SOCKETS & ACCESSORIES

SERIES 871:

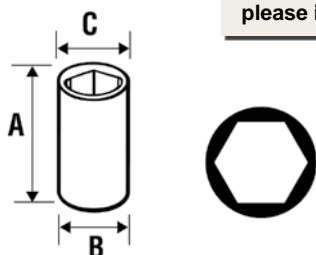

Description	Order No.	Price
1/4" Drive, 5.5" Long	10900	
3/8" Drive, 7.625" Long	11900	
1/2" Drive, 10.313" Long	12800	

TEAR DROP QUICK RELEASE FLEX HEAD RATCHET



Description	Order No.	Price
3/8" Drive, 11.375" Long	11922	
1/2" Drive, 16.750" Long	12802	

FLEX HANDLE



Description	Order No.	Price
1/4" Drive, 5.5" Long	10920	
3/8" Drive, 9.5" Long	11920	
1/2" Drive, 15" Long	12820	
1/2" Drive, 18" Long	12821	

EXTENSIONS



Description	Order No.	Price
1/4" Drive, 1.5 Long	7110902	
1/4" Drive, 3" Long	9910905	
1/4" Drive, 6" Long	9910910	
3/8" Drive, 1.5" Long	11902	
3/8" Drive, 3" Long	11905	
3/8" Drive, 6" Long	11910	
3/8" Drive, 10.5" Long	11912	
3/8" Drive, 20" Long	11915	
1/2" Drive, 2" Long	12803	
1/2" Drive, 3" Long	12805	
1/2" Drive, 5" Long	12810	
1/2" Drive, 10" Long	12812	
1/2" Drive, 20" Long	12814	

ADAPTERS & UNIVERSAL JOINTS



Description	Order No.	Price
1/4F x 3/8M Adapter	10925	
1/4" Drive, 1.30" Universal Joint	10930	
3/8F x 1/2M, 1.405" Long Adapter	11925	
3/8F x 1/4M, 1.000" Long Adapter	11927	
3/8" Drive, 2" Long Universal Joint	1930	
1/2F x 3/8M, 1.440" Long Adapter	12827	
1/2F x 3/4M 1.755" Long Adapter	12828	
1/2" Drive, 2.69" Universal Joint	12830	

(Continued)

Size	Dimensions			Order No.	Price	Size	Dimensions			Order No.	Price
	A	B	C				A	B	C		
6 PT. STANDARD SOCKETS 1/4" DRIVE						6 PT. DEEP SOCKETS 1/4" DRIVE					
5/32"	.883	.458	.280	10021		3/16"	2.010	.453	.315	10052	
3/16"	.883	.458	.315	10022		7/32"	2.010	.477	.356	10053	
7/32"	.883	.458	.353	10023		1/4"	2.010	.453	.397	10054	
1/4"	.883	.458	.390	9910024		9/32"	2.010	.453	.438	9910055	
9/32"	.883	.458	.426	9910025		5/16"	2.010	.458	.458	10056	
5/16"	.883	.455	.455	10026		11/32"	2.010	.505	.505	9910057	
11/32"	.883	.502	.502	10027		3/8"	2.010	.540	.540	9910058	
3/8"	.833	.537	.537	9910028		7/16"	2.010	.620	.620	10059	
7/16"	.833	.617	.617	9910029		1/2"	2.010	.694	.694	10060	
1/2"	.833	.694	.694	10030							

3/8" & 1/2" DRIVE SOCKETS & ACCESSORIES

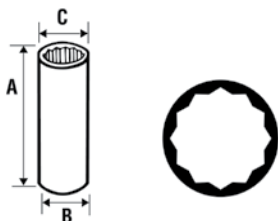

Size	Dimensions			Order No.	Price	Size	Dimensions			Order No.	Price
	A	B	C				A	B	C		
12 PT. STANDARD SOCKETS 3/8" DRIVE						12 PT. DEEP SOCKETS 3/8" DRIVE					
5/16"	.945	.662	.460	11206		3/8"	2.513	.667	.568	11258	
3/8"	.945	.664	.568	11208		7/16"	2.513	.664	.664	11259	
7/16"	.945	.664	.664	11209		1/2"	2.513	.706	.706	11260	
1/2"	.975	.703	.703	11210		9/16"	2.513	.786	.786	11261	
9/16"	.975	.779	.779	11211		5/8"	2.513	.870	.870	11262	
5/8"	1.020	.851	.851	11212		11/16"	2.513	.925	.925	11263	
11/16"	1.020	.925	.925	11213		3/4"	2.513	1.002	1.002	11264	
3/4"	1.135	1.002	1.002	11214		13/16"	2.526	1.085	1.085	11265	
13/16"	1.135	1.085	1.085	11215		7/8"	2.526	1.186	1.186	11266	
7/8"	1.205	1.186	1.186	11216							
12 PT. STANDARD SOCKETS 1/2" DRIVE						12 PT. DEEP SOCKETS 1/2" DRIVE					
3/8"	1.510	.874	.524	12208		1/2"	3.267	.876	.754	12260	
7/16"	1.510	.876	.684	12209		9/16"	3.267	.876	.818	12261	
1/2"	1.510	.876	.754	12210		5/8"	3.267	.876	.876	12262	
9/16"	1.510	.876	.818	12211		11/16"	3.267	.967	.967	12263	
5/8"	1.510	.876	.876	12212		3/4"	3.267	1.042	1.042	12264	
11/16"	1.510	.967	.967	12213		13/16"	3.267	1.130	1.130	12265	
3/4"	1.510	1.042	1.042	12214		7/8"	3.267	1.195	1.195	12266	
13/16"	1.510	1.122	1.122	12215		15/16"	3.267	1.274	1.274	12267	
7/8"	1.510	1.186	1.186	12216		1"	3.267	1.274	1.274	12268	
15/16"	1.510	1.262	1.262	12217		1-1/16"	3.267	1.426	1.426	12269	
1"	1.635	1.340	1.340	12218		1-1/8"	3.267	1.507	1.507	12270	
1-1/16"	1.635	1.414	1.414	12219							
1-1/8"	1.697	1.495	1.495	12220							
1-1/4"	1.770	1.650	1.650	12222							
1-1/2"	1.920	1.972	1.972	9912226							



1/4", 3/8", & 1/2" SOCKET SETS IN METAL BOX

SERIES 871:



OR OTHER FINE BRANDS



13 PIECE ---- 1/4" DRIVE SOCKET SET

Order No. 19009 Price

INCLUDES: Nine 6 pt. Std. Sockets: 3/16", 7/32", 1/4", 9/32", 5/16", 11/32", 3/8", 7/16", 1/2"; 1-1/2" Extension; 6" Extension; Spinner Handle; Round Head Ratchet; in a metal box.

14 PIECE ---- 1/4" DRIVE METRIC SOCKET SET

Order No. 19019 Price

INCLUDES: Ten 6 pt. Std. Sockets: 4mm, 5mm, 6mm, 7mm, 8mm, 9mm, 10mm, 11mm, 12mm; 13mm; 1-1/2" Extension; 6" Extension; Spinner Handle; Round Head Ratchet; in a metal box.

12 PIECE ---- 3/8" DRIVE FRACTIONAL SOCKET SET

Order No. 19135 Price

INCLUDES: Eight 12 pt. Std. Sockets: 3/8", 7/16", 1/2", 9/16", 5/8", 11/16", 3/4", 13/16"; Spark Plug Skt 5/8"; 3" Extension; 6" Extension; Round Head Ratchet; in a metal box.

14 PIECE ---- 3/8" DRIVE METRIC SOCKET SET

Order No. 19137 Price

INCLUDES: Ten 12 pt. Std. Sockets: 10mm, 11mm, 12mm, 13mm, 14mm, 15mm, 16mm, 17mm, 18mm, 19mm; Spark Plug Skt 5/8"; 3" Extension; 6" Extension; Round Head Ratchet; in a metal box.

18 PIECE ---- 3/8" DRIVE SOCKET SET

Order No. 19136 Price

INCLUDES: Seven 12 pt. Std. Sockets: 3/8", 7/16", 1/2", 9/16", 5/8", 11/16", 3/4"; Spark Plug Skt 5/8"; Seven 12 pt. Dp. Sockets: 3/8", 7/16", 1/2", 9/16", 5/8", 11/16", 3/4"; 3" Ext.; 6" Ext.; Round Head Ratchet; in a metal box.



12 PIECE ---- 1/2" DRIVE SOCKET SET

Order No. 19220 Price

INCLUDES: Ten 12 pt. Std. Sockets: 7/16", 1/2", 9/16", 5/8", 11/16", 3/4", 13/16", 7/8", 15/16", 1"; 6" Extension; Round Head Ratchet; in a metal box.

15 PIECE ---- 1/2" DRIVE METRIC SOCKET SET

Order No. 19221 Price

INCLUDES: Thirteen 12 pt. Std. Sockets: 10mm, 12mm, 13mm, 14mm, 17mm, 18mm, 19mm, 22mm, 23mm; 24mm, 25mm, 27mm, 28mm; 6" Extension; Round Head Ratchet; in a metal box.

16 PIECE ---- 1/2" DRIVE FRACTIONAL SOCKET SET

Order No. 19211 Price

INCLUDES: Thirteen 12 pt. Std. Sockets: 7/16", 1/2", 9/16", 5/8", 11/16", 3/4", 13/16", 7/8", 15/16", 1"; 1-1/16", 1-1/8", 1-1/4"; 6" Extension; Flex Handle 15"; Quick Release Ratchet; in a metal box.

1/4", 3/8", & 1/2" SOCKET SETS IN POLYETHYLENE CASE

SERIES 871:

57 PIECE ---- 1/4" & 3/8" FRACTIONAL / METRIC SOCKET SET

Order No. 19125 Price

INCLUDES: Twenty 6 pt. 1/4 Std. Sockets: 5/32", 3/16", 7/32", 1/4", 9/32", 5/16", 11/32", 3/8", 7/16", 1/2"; 4mm, 5mm, 6mm, 7mm, 8mm, 9mm, 10mm, 11mm, 12mm, 13mm; Eighteen 12 pt. 3/8" Std. Sockets: 3/8", 7/16", 1/2", 9/16", 5/8", 11/16", 3/4", 13/16", 9mm, 10mm, 11mm, 12mm, 13mm, 14mm, 15mm, 16mm, 17mm, 19mm; Five 12 pt. 3/8" Deep Sockets: 3/8", 7/16", 1/2", 9/16", 3/4"; 6 pt. 3/8" Spark Plug Socket 5/8"; 1/4" Spinner Handle; 1/4" Extension: 1-1/2"; Two 3/8" Extensions: 3", 6"; 3/8" Adapter: 3/8"F-1/4"M; 3/8" Teardrop Ratchet; Seven Short Arm Hex Keys: 5/64", 3/32", 1/8", 5/32", 3/16", 7/32", 1/4"; in a high density polyethylene case.

72 PIECE ---- 1/4" & 3/8" DRIVE FRACTIONAL / METRIC SOCKET SET

Order No. 19138 Price

INCLUDES: Twenty 6 pt. 1/4 Std. Sockets: 5/32", 3/16", 7/32", 1/4", 9/32", 5/16", 11/32", 3/8", 7/16", 1/2"; 4mm, 5mm, 6mm, 7mm, 8mm, 9mm, 10mm, 11mm, 12mm, 13mm; Eighteen 12 pt. 3/8" Std. Sockets: 3/8", 7/16", 1/2", 9/16", 5/8", 11/16", 3/4", 13/16", 9mm, 10mm, 11mm, 12mm, 13mm, 14mm, 15mm, 16mm, 17mm, 19mm; Five 12 pt. 3/8" Deep Sockets: 3/8", 7/16", 1/2", 9/16", 3/4"; 6 pt. 3/8" Spark Plug Socket 5/8; 1/4" Spinner Handle; 1/4" Teardrop Ratchet; 1/4" Extension: 1-1/2"; Two 3/8" Extensions: 3", 6"; 3/8" Adapter 3/8"F-1/4"M; 3/8" Teardrop Ratchet; 5 Pc. Combination Wrench Set.; 6 Pc. Duracast Hex Key / Screwdriver Fold-up; Fifteen Short Arm Hex Keys: .028", .035", .050", 1/16", 5/64", 3/32", 7/64", 1/8", 9/64", 5/32", 3/16", 7/32", 1/4", 5/16", 3/8"; in a high density polyethylene case.



While we show only the most popular **ALLEN** items we can supply their entire range of products; please inquire.

INDUSTRIAL SUPPLIES

(Continued)



1/4", 3/8", & 1/2" SOCKETS SETS

SERIES 871:
(Continued)



INDUSTRIAL SUPPLIES



IN POLYETHYLENE CASE



IN ZIPPERED CASE

**85 Piece Fractional/Metric
1/4" and 3/8" Drive Socket Set**

Order No. 19144

Price

85 Piece Set Includes:

- | | |
|------------------------------------|---|
| 1/4" Dr. Round Hd Ratchet | 12-Pt. 3/8" Dr. Deep Sockets: |
| 3/8" Dr. Round Hd Ratchet | 3/8", 7/16", 1/2", 9/16", 5/8", |
| 6 Pt. 1/4" Dr Std Sockets: | 11/16", 3/4", 13/16", 7/8" |
| 5/32", 3/16", 7/32", 1/4", 9/32", | 12-Pt. 3/8" Dr. Metric Deep Sockets: |
| 5/16", 11/32", 3/8", 7/16", 1/2" | 10mm - 19mm |
| 6-Pt. 1/4" Dr. Metric Std Sockets: | 6-Pt. 3/8" Dr. 5/8" Spark Plug Socket |
| 4mm - 13mm | 6-Pt. 3/8" Dr. 13/16" Spark Plug Socket |
| 12-Pt. 3/8" Dr. Std Sockets: | 1/4" Dr. Spinner Handle |
| 3/8", 7/16", 1/2", 9/16", 5/8", | 3/8" Dr. 3/8" to 1/4" Reducing Adapter |
| 11/16, 3/4", 13/16" | 1/4" Dr. 3" Extension Bar |
| 12-Pt. 3/8" Dr. Std Sockets: | 3/8" Dr. 3" Extension Bar |
| 10mm - 19mm | Short Arm Hex Keys: |
| 6-Pt. 1/4" Dr. Deep Sockets: | 5/64", 3/32", 1/8", 5/32", 3/16", |
| 3/16", 7/32", 1/4", 9/32", 5/16", | 7/32", 1/4" |
| 11/32", 3/8", 7/16" | High Density Polyethylene Case |
| 6-Pt 1/4" Dr Metric Deep Sockets: | |
| 6mm - 10mm | |

**41 Piece Fractional/Metric
1/4" and 3/8" Drive Socket Set**

Order No. 19142

Price

41 Piece Set Includes:

- | | |
|-----------------------------------|---------------------------------------|
| 3/8" Dr. Round Head Ratchet | Sockets: |
| 6-Pt. 1/4" Dr. Std Sockets: | 10mm-15mm & 17mm-19mm |
| 5/32", 3/16", 7/32", 1/4", 9/32", | 12-Pt. 3/8" Dr. Deep Sockets: |
| 5/16", 11/32", 3/8" | 3/8", 7/16", 1/2", 9/16", 5/8" |
| 6-Pt. 1/4" Dr. | 6-Pt. 3/8" Dr. 5/8" Spark Plug Socket |
| Metric Std Sockets: | 1/4" Dr. Spinner Handle |
| 4mm - 10mm | 3/8", Dr. 3/8" to 1/4" Reducing |
| 12-Pt. 3/8" Dr. Std Sockets: | Adapter 3/8", Dr. 3" Extension Bar |
| 3/8", 7/16", 1/2", 9/16", 5/8", | |
| 11/16", 3/4" | |
| 12-Pt. 3/8" Dr. Metric Std | |

**107 Piece Fractional/Metric
1/4", 3/8" & 1/2" Drive Socket Set**

Order No. 19222

Price

107 Piece Set Includes:

- | | |
|---|---|
| 1/4" Dr. Round Hd Ratchet | 12-Pt. 3/8" Dr. Deep Sockets: |
| 3/8" Dr. Round Hd Ratchet | 3/8", 7/16", 1/2", 9/16", 5/8", |
| 1/2" Dr. Round Hd Ratchet | 11/16", 3/4", 13/16", 7/8" |
| 6 Pt. 1/4" Dr Std Sockets: | 12-Pt. 3/8" Dr. Metric Deep Sockets: |
| 5/32", 3/16", 7/32", 1/4", 9/32" | 10mm - 19mm |
| 5/16", 11/32", 3/8", 7/16", 1/2" | 12-Pt. 1/2" Dr. Deep Sockets: |
| 6-Pt. 1/4" Dr. Metric Std Sockets: | 1/2", 9/16", 5/8", 11/16" |
| 4mm - 13mm | 6-Pt. 3/8" Dr. 5/8" Spark Plug Socket |
| 12-Pt. 3/8" Dr. Std Sockets: | 6-Pt. 3/8" Dr. 13/16" Spark Plug Socket |
| 3/8", 7/16", 1/2", 9/16", 5/8", 11/16", | 1/4" Dr. Spinner Handle |
| 3/4", 13/16" | 3/8" Dr. 3/8" to 1/4" Reducing Adapter |
| 12-Pt. 3/8" Dr. Metric Std Sockets: | 1/4" Dr. 3" Extension Bar |
| 10mm - 19mm | 3/8" Dr. 3" Extension Bar |
| 12-Pt. 1/2" Dr. Std Sockets: | 1/2" Dr. 3" Extension Bar |
| 1/2", 9/16", 5/8", 11/16", 3/4", | Short Arm Hex Keys: |
| 13/16", 7/8", 15/16" | 5/64", 3/32", 1/8", 5/32", 3/16", |
| 12-Pt. 1/2" Dr. Metric Std Sockets: | 7/32", 1/4" |
| 18mm - 22mm | High Density Polyethylene Case |
| 6-Pt. 1/4" Dr. Deep Sockets: | |
| 3/16", 7/32", 1/4", 9/32", 5/16", | |
| 11/32", 3/8", 7/16" | |
| 6-Pt. 1/4" Dr Metric Deep Sockets: | |
| 4mm - 11mm | |

HEX BIT SOCKET SETS



9 PIECE — 3/8" DRIVE HEX BIT SOCKET SET

ORDER No. 9956370

Price

INCLUDES: Nine Bit Sockets: 7/64", 1/8", 9/64", 5/32", 3/16", 7/32", 1/4", 5/16", 3/8"; in a metal box.

8 PIECE — 3/8" DRIVE METRIC HEX BIT SOCKET SET

ORDER No. 9956368

Price

INCLUDES: Eight Bit Sockets: 2mm, 2.5mm, 3mm, 4mm, 5mm, 6mm, 8mm, 10mm; in a metal box.

TRU-LOK® MEASURING TAPES
SERIES 791:



- Tough Tip® Blade Protector standard on all 1" and 3/4" (25 and 19 mm) blades
- Rugged, impact resistant case



Industrial Quality Tape Measures with heavy-duty blades as standard. This is the basic measuring tape style used by professionals and homeowners throughout the world. They are named Tru-Lok® because the blade positively locks in position until the cam-activated lock button is released. A new, heavy-duty tape line is

furnished standard, making the tape ideal for work under demanding conditions. Tru-Lok® tapes are available in five case colors — smooth, shiny chrome cases (considered by many to be the "class" of measuring tapes), charcoal black and three high-visibility colors (another Starrett innovation) that easily stand out in the toolbox, workbench or job site.

Length	Grad.	Case Color	Catalog No.	EDP No.	Price	
1/2" (13mm) Tru-Lok® Tapes						
12'	S1	Chrome	C12-12	65418		
12'	S1	Charcoal	CH12-12	65942		
12'	S1	Yellow	Y12-12	65943		
4M	S8	Chrome	C12-4M8	65781		
4M /12'	S9	Chrome	C12-4ME9	65782		
4M /12'	S12	Chrome	C12-4ME12	65784		
4M /12'	S12	Charcoal	CH12-4ME12	65944		
3/4" (19mm) Tru-Lok® Tapes						
16'	S1	Chrome	C34-16	65386		
16'	S1	Charcoal	CH34-16	65937		
16'	S1	Neon Orange	O34-16*	65387		
16'	S1	Yellow	Y34-16	65938		
5M	S6	Chrome	C34-5M6	65755		
5M/16'	S9	Chrome	C34-5ME9	65758		
5M/16'	S11	Chrome	C34-5ME11	65759		
5M/16'	S12	Chrome	C34-5ME12	65760		
5M/16'	S12	Charcoal	CH34-5ME12	65939		
25'	S1	Charcoal	CH34-25	65940		
8M/26'	S12	Charcoal	CH34-8ME12	65941		
1" (25mm) Tru-Lok® Tapes						
25'	S1	Chrome	C1-25	65366		
25'	S1	Charcoal	CH1-25	65932		
25'	S1	Yellow	Y1-25	65933		
8M	S6	Chrome	C1-8M6	65743		
8M/26'	S9	Chrome	C1-8ME9	65746		
8M/26'	S12	Chrome	C1-8ME12	65748		
88M/26'	S12	Lime Green	G1-8ME12*	65754		
8M/26'	S12	Charcoal	CH1-8ME12	65934		
30'	S1	Chrome	C1-30	65382		
30'	S1	Neon Orange	O1-30*	65383		
30'	S1	Yellow	Y1-30	65936		
30'	S1	Charcoal	CH1-30	66209		
33'	S1	Yellow	Y1-33	66408		
10M/33'	S12	Yellow	Y1-10ME12	66379		

*Limited Quantity

GRADUATION CODES

S1 English Regular - feet, inches, 1/16"
S3...Diameter Tape - inches, 1/16" one side, diameter inches other side.
S3A. 1/4" Tape - inches, 1/16"

S6...Millimeter graduations, centimeter numbering full length.
S8...Millimeter graduations, millimeter numbering to each decimeter and repeat.

Metric Only

S9...Millimeter graduations, centimeter numbering to end one edge, feet, inches 1/16" other edge.
S12..Millimeter graduations, millimeter numbering to each decimeter and repeat one edge, feet, inches, 1/16" other edge.

English/Metric

AUTOMATIC CONTROLOK® TAPE MEASURES

SERIES 791:



- New tape design features top mounted control lever allowing automatic locking of blade when thumb pressure is released. No accidental blade retraction like on bottom lock tapes.
- Rubber top grip, compact size for comfort and easy handling.
- Heavy duty UV top-coated blades.
- Yellow blades
- Tough-Tip® blade protectors.

Blade Length	Catalog No.	EDP No.	Case Color	Graduation Style	Price
1/2" (13mm)					
12'	AY12-12	65927	Yellow	S1	
4M/12'	AG12-4ME9*	65728	Lime Green	S9	
3/4" (19mm)					
16'	AC34-16*	65304	Chrome	S1	
16'	AO34-16*	65305	Neon Orange	S1	
16'	AY34-16	65926	Yellow	S1	
5M/16'	AG34-5ME9*	65692	Lime Green	S9	
1" (25mm)					
25'	AC1-25*	65284	Chrome	S1	
25'	AY1-25	65925	Yellow	S1	
8M	AC1-8M6*	65671	Chrome	S6	
8M/26'	AC1-8ME9*	65674	Chrome	S12	
8M/26'	AY1-8ME12	66197	Yellow	S9	
33'	AY1-33	66397	Yellow	S1	
10M/33'	AY1-10ME12	66402	Yellow	S12	

*Limited Quantity

RE-TAPE™ MEASURING TAPE

SERIES 791:



Re-Tape has the same design features as our Tru-Lok® tapes, except the case consists of reground materials from other Starrett cases and it has a regular end-hook (not a Tough Tip®). Furnished with a new (not recycled) 1" blade, it is a durable tape, great for the environment, and also attractively priced.



*Limited Quantity

Length	Blade Width	Grad.	Catalog No.	EDP No.	Price
25'	1"	S1	CS1-25-1	64183*	
8M/26'	1" (25 mm)	S12	CS1-8ME	65897*	

CODE TAPE™ MEASURING TAPE

SERIES 791:

This rugged tape with Tru-Lok® design features a heavy-duty blade as standard, has special information printed on the blade that commercial builders and contractors will appreciate. The 1" blade gives practical information for the building, locating and installation of various equipment required by the ADA (Americans with Disabilities Act). Available in chrome case.



1" X 25' RAPID-RETAPE™ SERIES 791:



Now Re-Tape has fractional readouts!

- Quick reading convenient 1/8" fractional readouts clearly marked on the blade. (S1 Graduation)
- Enviro-Friendly – made from recycled cases and a new 1" x 25' steel blade.
- Rugged, impact-resistant case.
- Tru-Lok® positive lock to prevent blade pull back.



Catalog No. CSR1-25

Order No. 66549 Price:

LIMITED QUANTITY

Length	Blade Width	Catalog No.	EDP No.	Price
25'	1"	CT1-25	65896	

PI Tape® SERIES 338:



Only One Diameter Measurement Necessary

The periphery tape or **Pi Tape®** gage, provides a quick, accurate and easy method of reading true diameters of both round and out-of-round forms. Perfect for measurement of thin or soft walled parts — large or small.

Pi Tape® gages consist of a narrow metal ribbon bearing special graduations. These graduations are designed to convert circumferential distance into diameter measurement so the observer can read the diameter directly from the scale.

Tapes are checked over master gages at .001" (.03mm) accuracy for standard tapes up to 144" (3600mm). Certificate of accuracy traceable to National Institute of Standards and Technology is furnished.

Pi Tape® gages are a precision tool made of 1095 clock spring steel (on request 420 stainless steel — for use in a corrosive atmosphere). They require a minimum of maintenance, but we do recommend a quick wipe with an oil moistened cloth after use. A light gun oil works very well.

Standard tapes have graduations and numerals that are engraved and acid etched on a ground surface. The tape has a fixed reading that does not require periodic adjustments.

English reading tapes read to .001" diameter.
Accuracy of standard tapes ± .001" up to 144".

Metric reading tapes read to 0.01mm diameter.
Accuracy of standard tapes ± 0.03mm up to 3600mm.

Calibration performed in accordance with ANSI/NC SL Z540-1-1994, ISO/IEC Guide 25 and Mil-Std. 45662A.

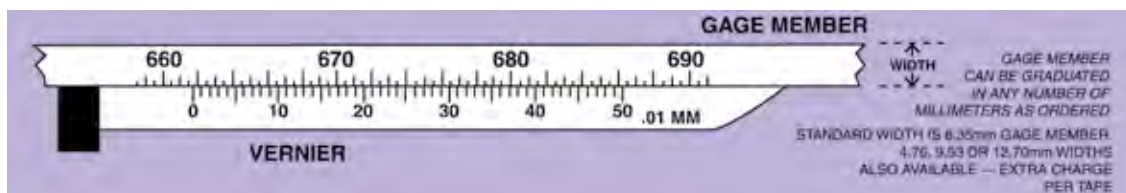
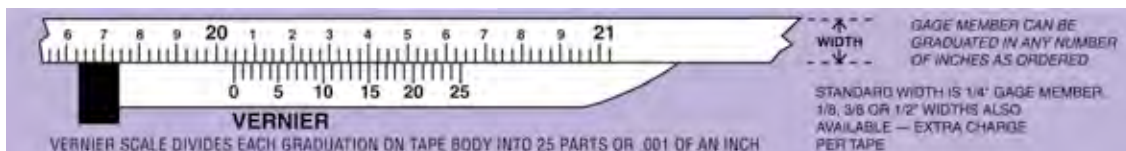

METRIC

INCH

Part No.	Dia. mm	Gage Member mm	Thickness mm	Body Width mm	Order No.	Price	Part No.	Dia. Inches	Gage member	Thickness	Body Width	Order No.	Price
PM0	28-200	6.35	0.18	12.7	3380000		P000	.500" to 2"	1/4"	.007"	1/2"	3385000	
PM1	100-300	6.35	0.25	12.7	3380001		P01	.75" to 7"	1/4"	.007"	1/2"	3385201	
PM1SP	50-600	6.35	0.25	12.7	3380101		P1	2" to 12"	1/4"	.010"	1/2"	3385001	
PM2	300-600	6.35	0.25	12.7	3380002		P1SP	2" to 24"	1/4"	.010"	1/2"	3385101	
PM2SP	300-900	6.35	0.25	12.7	3380102		P2	12" to 24"	1/4"	.010"	1/2"	3385002	
PM3	600-900	6.35	0.25	12.7	3380003		P2SP	12" to 36"	1/4"	.010"	1/2"	3385102	
PM3SP	600-1200	6.35	0.25	12.7	3380103		P3	24" to 36"	1/4"	.010"	1/2"	3385003	
PM4	900-1200	6.35	0.25	12.7	3380004		P3SP	24" to 48"	1/4"	.010"	1/2"	3385103	
PM5	1200-1500	6.35	0.25	12.7	3380005		P4	36" to 48"	1/4"	.010"	1/2"	3385004	
PM6	1500-1800	6.35	0.25	12.7	3380006		P5	48" to 60"	1/4"	.010"	1/2"	3385005	
PM7	1800-2100	6.35	0.25	12.7	3380007		P6	60" to 72"	1/4"	.010"	1/2"	3385006	
PM8	2100-2400	6.35	0.25	12.7	3380008		P7	72" to 84"	1/4"	.010"	1/2"	3385007	
PM9	2400-2700	6.35	0.25	12.7	3380009		P8	84" to 96"	1/4"	.010"	1/2"	3385008	
PM10	2700-3000	6.35	0.25	12.7	3380010		P9	96" to 108"	1/4"	.010"	1/2"	3385009	
PM11	3000-3300	6.35	0.25	12.7	3380011		P10	108" to 120"	1/4"	.010"	1/2"	3385010	
PM12	3300-3600	6.35	0.25	12.7	3380012		P11	120" to 132"	1/4"	.010"	1/2"	3385011	
							P12	132" to 144"	1/4"	.010"	1/2"	3385012	

PRECISION LEVELS

SERIES 258:



Includes fitted wooden case.

The main level is graduated to 10 second accuracy (1 division equals .0005" per 10").

Body of level is made of cast iron and base is hand scraped for extreme accuracy. Base is "V" shaped for checking round work. Plastic grips on frame insulate instrument from heat of hand.

Model No.	Length	Ordering No.	Price
PL8	8"	1740008	
PL12	12	1740012	



LEVELS
SERIES 789:



SMALL BENCH LEVEL

STARRETT SERIES 130:



3-3/8"/85mm long with sensitive and accurate single vial. Sturdy body made of seasoned cast iron with black wrinkle finish and nickel plated ends. Accurately machined base leveling surface.

Size	Catalog No.	EDP No.	Price
3-3/8"/85mm	130	50560	

MECHANICS' IMPROVED LEVELS

STARRETT SERIES 98:



Levels have ground and graduated main vials. All levels have cross test vial, except 4" size. 12" size has in addition a plumb vial, and 18" size a double plumb vial. Plumb vials on 12" and 18" levels are ground. Main vials are adjustable for positive setting and housed in a satin-chromed brass tube with friction fit closing cover to prevent breakage. Level base are of the finest seasoned castings with black wrinkle finish, accurately machined and finished on bearing surface. An involute longitudinal groove between bearing flats provides accurate seating on round work.

SPECIFICATIONS

Size	Catalog No.	EDP No.	Price
4"	98-4	50440	
6	98-6	50441	
8	98-8	50442	
12	98-12	50443	
12	982-12*	50444	
18	98-18	50445	
18	982-18*	50446	

* Supplied in fitted case.

CROSS TEST LEVEL AND PLUMB

STARRETT SERIES 134:

For approximate squaring, leveling, machine set up. Has two vials at right angles for cross test leveling without moving tool and a plumb level at the top for checking squareness.

Reliable and compact, weighs 3 ounces.



Size	Catalog No.	EDP No.	Price
2" x 3" x 1/2"/ 50 x 75mm	134	50569	

MASTER PRECISION LEVEL

STARRETT SERIES 199:



For critical machinery set-ups of all types. Ground and graduated main vial of 10-second accuracy – one division equals .0005" per foot. Auxiliary level vial shows lateral position as guide to horizontal setting. Insulated from handling by non-conductive top plate. Level vials positioned to reduce breakage. Made of seasoned cast iron. Base carefully machined and scraped. Black wrinkled finish on non-working surfaces. Furnished in wood case.

Length Base	Width Base	Height Level	Catalog No.	EDP No.	Price
15"/ 380mm	1-5/8"/ 40mm	3"/75mm	199Z	50719	

CROSS TEST LEVEL

STARRETT SERIES 136:



Has two vials at right angles for leveling in both directions without moving level from work. Compact, measuring 2-3/4" x 2-3/4" and weighs only 4 ounces. Attractive black wrinkle finish and a ground reference surface.

Catalog No.	EDP No.	Size	Description	Price
136	50572	2-3/4" x 2-3/4"	With cross test vials	

BENCH LEVELS

STARRETT SERIES 132:



All have main vial and double plumb vial with two graduated lines. Made of seasoned cast iron with black wrinkle finish, accurately machined on leveling surfaces. Bottom of base has involute groove for accurately seating level on cylindrical work. Flat lands and groove in the bottom of the base are machined at one setting, thereby assuring complete accuracy.

Size	Catalog No.	EDP No.	Price
6"150mm	132-6	50562	
9"-225mm	132-9	50563	
12"-300mm	132-12	50564	
24"-600mm	132-24	50566	

POCKET LEVELS

STARRETT SERIES 135:



Handy level, satin nickel plated finish. Available in 2-1/2" and 3-1/2" sizes made from hexagonal stock 3/8" and 1/2" wide respectively. Made with convex ends.

Description	Size	Catalog No.	EDP No.	Price
With main vial	2-1/2"	135A	50570	
With main vial	3-1/2"	135B	50571	

MASTER PRO™ MAHOGANY/ALUMINUM LEVELS MP SERIES



These levels are top of the line for Starrett-Exact products. Often prized by craftsmen, they are not only accurate and sturdy, but attractive and easy to handle.

Limited Quantities

- Mahogany construction, reinforced with an aluminum I-beam frame and working edge.
- Tough, yellow Pyrex vials with large bubbles and ceramic fired lines for fast, dependable reading.
- Clear glass windows protect vials from dirt and damage.
- Shock-absorbing end caps protect working edges and preserve accuracy.
- Holes for convenient hanging.

Size In.	Size Metric	Description	Catalog No.	Order No.	Price
24"	60 cm	6 Vials (4 Plumb, 2 Level)	MP-24	36004	
48"	120 cm		MP-48	36008	
72"	180 cm	8 Vials (4 Plumb, 4 Level), and Door Jamb Roller	MP-72	36009	
78"	198 cm		MP-78	36010	

BRASS BOUND MAHOGANY BB SERIES



These fine levels are crafted from fine mahogany and brass. A fine addition to the shop of a discriminating craftsman.

- Levels are made of finest mahogany and are permanently reinforced with double angle brass bindings.
- Tough, yellow Pyrex vials with large bubbles and ceramic fired lines for fast, dependable reading.
- Clear glass windows protect vials from dirt and damage.
- Brass edges provide added stability and wear for increased accuracy.
- Shock-absorbing end caps protect working edges and preserve accuracy.

Size In.	Size Metric	Description	Catalog No.	Order No.	Price
24"	60 cm	6 Vials (4 Plumb, 2 Level)	BB-24	36014	
48"	120 cm	Open Grips	BB-48	36016	

ALUMINUM LINE/POCKET LEVELS PE SERIES



Lightweight, durable aluminum construction prevents line sag. Sure-grip line hooks hold line and allows level to slide freely. Flat base for accurate surface leveling. Large vial sight. Permanently marked for fast, dependable readings.

Length	Description	Catalog No.	EDP No.	Price
3"	1 level vial with line hooks	E-3	36077	

DIE-CAST ALUMINUM LEVEL EP-24



- Extremely stable, die-cast construction.
- Working edges ground for accuracy, one edge ruled (1/8" and millimeters)
- Yellow vials with large bubbles and ceramic fired lines for fast dependable reading.
- Clear glass windows protect vials from dirt and damage.

Size In.	Size Metric	Description	Catalog No.	Order No.	Price
24"	60 cm	6 Vials (4 Plumb, 2 Level) Ruled Edge	EP-24	36022	

MASTER PRO HEAVY-DUTY DIE-CAST ALUMINUM MECHANICS' LEVELS ML Series



- Six function mechanics' level will level, plumb, check 45°, check pitch set pitch, and measure length.
- Extremely stable, die-cast construction.
- Graduated top-sight level vial indicates pitch (1/8" per foot)
- Working edges ground for accuracy.
- Clear glass windows protect vials from dirt and damage.
- Permanently marked rule affixed to top reads left to right (1/16") on one side and centering rule (1/8") on other.
- Locking pitch/grade-screw adjustment.
- Tough, yellow Pyrex vials with large bubbles and ceramic fired lines for fast dependable reading.

Size In.	Size Metric	Description	Catalog No.	Order No.	Price
18"	45 cm	4 Vials (2 Plumb, 1 Level, and 45°)	ML-18	36031	
24"	60 cm	Grade Screw Adjustment	ML-24	36032	

PROFESSIONAL STA-TRUE™ ALUMINUM LEVELS

STE Series / MST Series with Magnetic Edge



- One-piece extruded aluminum frame.
- I-beam cross-section with flanged edges for increased strength
- Permanently mounted acrylic vials require no adjustment.
- Rectangular vial sights with 360° viewing
- Large magnetic strip mounted flush to the working edge on one side of the MST Series models for increased holding power. Frees hands when leveling on ferrous surfaces.

Size In.	Size Metric	Description	Catalog No.	Order No.	Price
STE Series					
24"	60 cm	3 Vials (1 Plumb, 1 Level, and 45°)	STE-24	36053	
36"	90cm	3 Vials (2 Plumb, 1 Level)	STE-36	36055	
48"	120cm		STE-48	36056	
72"	180cm	5 Vials (3 Plumb, 2 Level)	STE-72	36057	
96"	240cm		*STE-96	36059	
MST Series					
24"	60cm	3 Vials (2 Plumb, 1 Level),	MST-24	36062	
48"	120cm	One Magnetic Edge	MST-48	36064	
72"	180cm	4 Vials (2 Plumb, 2 Level)	MST-72	36065	

* Made by special order



LEVELS
SERIES 43:



ALUMINUM TORPEDO LEVELS WITH GROOVED OR MAGNETIC BASE

A-9 / M-9



These levels have a cast aluminum frame with working surfaces that are ground for accuracy. The A-9 has a V-grooved base for plumbing and tubular work. The M-9 has a strong magnet set in the base to hold the level securely to iron and steel surfaces.

Base	Description	Catalog No.	Order No.	Price
V-Grooved	3 Vials (1 Plumb, 1 Level, and 45°)	A-9	36069	
Magnetic	Side and Top Reading	M-9	36070	

ALUMINUM TORPEDO LEVEL WITH MAGNETIC BASE AND GROOVED TOP SURFACE™

AM-9



This level has a cast aluminum frame with working surfaces that are lapped for accuracy. A strong magnetic base holds the level securely to iron and steel surfaces. The V-grooved top working surface is ideal for plumbing and tubular work.

Description	Catalog No.	Order No.	Price
3 Vials (1 Plumb, 1 Level, 1 45°) Side and Top Reading	AM-9	36071	

COLORED TORPEDO LEVEL W/MAGNETIC BASE AND GROOVED TOP EDGE

PLM Series



Levels feature a precision molded, high impact styrene frame and are available in three colors. Levels with magnetic base hold securely to ferrous surfaces and a V-grooved top edge for plumbing and tubular work.

Color	Description	Catalog No.	Order No.	Price
Black	3 Vials	PLM-9*	36074	
Orange	(1 Plumb, 1 Level, 1 45°)	PLMO-9	64409	
Green	Side and Top Reading	PLMG-9*	64410	

*Limited Quantity

COLORED LINE/POCKET LEVELS WITH V-GROOVED BASE

PE Series

Lightweight, rugged plastic construction prevents line sag. Sure-grip line hooks hold line and allows level to slide freely. V-grooved base for surface leveling and tubular work. Large top and bottom vial sights. Permanently marked level vial for fast, dependable readings. Handy pocket clip. Available in three colors.



Color	Description	Catalog No.	Order No.	Price
Red	1 Vial Level	PE-2	36076	
Green	and pocket clip	PEG-2	36266	

HEAVY-DUTY ALUMINUM TOP READING LEVELS - BC-TA SERIES

BC-MTA SERIES With Magnetic Edge
With Unbreakable, Adjustable Block Vial System



- Heavy duty aluminum I-beam frame checked and adjusted for level and plumb on the job.
- Large top-reading level vial is magnified, florescent and open on three sides for easy viewing.
- Spring loaded level vial is easily checked and adjusted for level and plumb on the job.
- Magnetic edge version frees hands when leveling ferrous metal surfaces

Size		Description	Catalog No.	Order No.	Price
In.	Metric				
BC-TA Series					
24"	60 cm	3 Vials, Adjustable Vials	BC-TA-24	0036377	
48"	120 cm	(2 Plumb, 1 Top-Reading Level)	BC-TA-48	0036378	
BC-MTA Series With Magnetic Edge					
24"	60 cm	3 Vials, Adjustable Vials	BC-MTA-24	0036379	
48"	120 cm	(2 Plumb, 1 Top-Reading Level)	BC-MTA-48	0036380	

ECONOMY ALUMINUM LEVELS



- Medium-duty aluminum I-beam cross section with flanged edges for increased strength. Large octagonal vial sights for maximum visibility
- Permanently mounted 360° vials require no adjustment

Size	Description	Catalog No.	EDP No.	Price
18"	2 vials (1 plumb, 1 level)	ST2-18	36042	
24"	2 vials (1 plumb, 1 level)	ST2-24	36043	
24"	3 vials (2 plumb, 1 level)	ST3-24	36044	
48"	3 vials (2 plumb, 1 level)	ST3-48	36048	

ANGLE METER - AM-2

This angle meter from Starrett offers a fast, easy and inexpensive way to measure angles.

FEATURES:

- Large, readable scale for accurate readings from 0-90° in any quadrant.
- Magnetic base frees hands when used on ferrous surfaces.
- Measures any angle for pitch or slope.
- Handy rise, run, angle, and pitch information on back of tool



Catalog No. AM-2

Order No. 36080	Price:	
-----------------	--------	--

BULL'S-EYE CIRCULAR LEVEL - BE-1

- Level with all purpose, 360° vial reads in all directions.
- Sturdy plastic construction.
- Large sight for ease of reading.
- Ideal for home, workshop and industry.
- Level appliances, turntables, etc.
- 1-3/4" diameter, carry in your pocket.



Catalog No. BE-1

Order No. 36078	Price:	
-----------------	--------	--



PORTABLE SPRAY COOLANT SYSTEMS

SERIES 372:



DL SPRAY SYSTEM

The DL provides cooling solutions for light duty machining and tool room applications. The DL dispenser is easy to install requiring only shop air and dropping the siphon line into a coolant tank.

FEATURES:

- 7 inch flexible segmented nozzle.
- 7 foot coolant line with stainless steel filter.
- 60 pound magnetic base with mounting arm.
- 1/8" NPT air inlet fitting.



Description	Order No.	Price
DL Spray System	30660	
DL Spray System with 1 quart Tricool	30655	

DL MAGNUM SPRAY SYSTEM

The DL Magnum provides cooling solutions for light duty machining and tool room applications. The DL Magnum is easy to install requiring only shop air and dropping the siphon line into a coolant tank.

FEATURES:

- 15 inch flexible metal conduit.
- Independent air and liquid adjustment.
- 6 foot coolant line with stainless steel filter.
- Check valve minimizes delay of fluid upon start-up.
- 1/4" NPT air inlet fitting.



Fitting	Description	Order No.	Price
1/4 NPT	DL Magnum	30632	
1/4 NPT	DL Magnum w/1 quart Tricool	30633	

SPRAY COOLANT SYSTEMS MISTMATIC®

The Mistmatic offers a wide range of coolant delivery patterns. The pressure pumping design allows use with a wide range of coolants compatible with Buna-N seals and lower than 1000 SUS viscosity. Auto electric models, 120 VAC, can be interfaced with machine controls for cyclic capabilities.

FEATURES:

- 7 inch plastic nozzle with control valve.
- One or two outlets with 5 ft. brass armored lines.
- Independent air and liquid adjustment at the nozzle.
- 1 gallon dimensions, 10-1/2" H x 8-1/2" W x 6" D.
- 4 gallon dimensions, 14-1/2" H x 17-1/2" W x 9" D.



Capacity (gal.)		No. of Lines	Control Mode	Order No.	Price
Plastic	Stainless				
1	-	1	Manual	30600	
1	-	2	Manual	9930601	
4	-	1	Manual	9930602	
4	-	2	Manual	30603	
1	-	1	Auto	30604	
1	-	2	Auto	30605	
4	-	1	Auto	30606	
4	-	2	Auto	9930607	
-	1	1	Manual	30608	
-	1	2	Manual	30609	
-	1	1	Auto	30610	
-	1	2	Auto	30611	

SPRAYMASTER®

Spraymaster systems provide convenient spray cooling in metal cutting. Requiring only compressed air as a power source, these units are easily installed in many machining applications.

FEATURES:

- Independent air and liquid adjustment.
- 4 inch brass nozzle.
- 1 or 2 outlet with 5 ft. brass armored line.
- 1 gallon reservoirs available in polyethylene and stainless steel.
- Sight gauge for viewing liquid level.
- Polyethylene reservoir dimensions - 12-1/4" H x 10" W x 5-1/4" D.
- Stainless steel reservoir dimensions 9-3/8" H x 8-3/8" W x 5-1/4" D.



Reservoir	No. of Lines	Order No.	Price
Polyethylene	1	30542	
	2	30543	
Stainless Steel	1	30548	
	2	30549	

SPRAYMASTER II®

The Spraymaster II is designed for applications where the ability to cycle the delivery is required. Solenoid control of spray coolant allows instant on-off operation for use in fixtured secondary machining.

FEATURES:

- 7 Inch flexible plastic nozzle.
- 1 or 2 outlet with 5 ft. brass armored lines.
- Independent air and liquid adjustment.
- Size - 12-1/2" H x 10" W x 5-1/4" D



Description	Order No.	Price
Spraymaster II w/ One Line	30458	
Spraymaster II w/ Two Lines	30459	

LI'L MISTER® SYSTEM

The compact size with a 1 quart reservoir makes the Li'l Mister ideal for tool room and other light duty machining applications. Typical applications include drilling, milling, turning, grinding and tapping.

FEATURES:

- Sight gauge for viewing of liquid level.
- 4 ft. plastic or brass armored line.
- Independent air and liquid adjustment.
- 3 inch straight brass nozzle.
- Size - 8-1/2" H x 5-1/4" W x 4" D.



Description	Order No.	Price
Li'l Mister with Plastic Lines	30540	
Li'l Mister with Brass Armored Lines	30541	

"SST" SPRAY COOLANT SYSTEMS

The "SST" coolant systems offers spray cooling with features normally costing much more. This unit is designed for production type applications where less frequent filling is desirable. Quality construction is evident in the 1 gallon stainless steel reservoir.

FEATURES:

- Independent air and liquid adjustment.
- 6 inch brass nozzle.
- 1 or 2 outlet with 4 ft. plastic line.
- Size - 8-7/8" H x 8-3/8" W x 5-5/32" D.



Description	Order No.	Price
"SST" Spray System w/ One Line	30546	
"SST" Spray System w/ Two Lines	30547	



PORTABLE SPRAY COOLANT SYSTEMS

SERIES 372:



TYPE "B" SPRAY COOLANT SYSTEMS

This system provides spray coolant delivery at up to six separate locations. Each line can be individually set for exact delivery. Independent air and coolant controls enable users to balance the delivery of coolant to each application. Type B models are suited to applications where multiple cutting locations, large diameter tools or higher heat transfer requirements are desired.



FEATURES:

- 5 gallon polyethylene reservoir.
- 1 to 6 outlet with 5 ft. brass armored delivery lines.
- Independent air and liquid adjustment.
- Reservoir handle for portability.
- Size - 15"H x 12 - 3/8" Diameter.

Description	Order No.	Price
"B" Spray Coolant System One Line	9930550	
"B" Spray Coolant System Two Lines	30551	
"B" Spray Coolant System Three Lines	30552	
"B" Spray Coolant System Four Lines	30553	
"B" Spray Coolant System Five Lines	30554	
"B" Spray Coolant System Six Lines	30556	

SYNTHETIC COOLANT

TRI-COOL®

For flood cooling and spray applications, Tri-Cool synthetic coolant is designed to provide optimum performance and long life for most metal cutting operations. Tri-Cool is excellent for use with ferrous and non-ferrous metals including stainless steel, aluminum, titanium, brass, bronze, and copper. It can be used for milling, tapping, drilling, grinding, turning, and sawing.



FEATURES:

- Non-hazardous synthetic formula improves operator safety.
- Synthetic E.P. Additives reduce heat build-up and extend tool life.
- Corrosion resistant even at high dilutions for improved rust protection.

Description	Order No.	Price
Gallons 4/Case	306561	
5 Gallon Pail	30657	



While we show only the most popular items we can supply their entire range of products; please inquire.



Coolant Systems and Accessories

The Choice Is Yours!!!

MICRO-DISPENSING SYSTEM

MD - 1200 MICRO-DROP®

The MD - 1200 dispenser provides a cost effective solution when flood cooling is impractical or unavailable. When used in milling, tapping, and sawing applications, the MD - 1200 dispenses small amounts of lubricant. Compared to flood cooling, there is no coolant sump to maintain or used coolant to dispose of. When compared to dry machining the MD - 1200 offers higher material removal rates, improved part finish, longer tool life, and tighter dimensional tolerances. Solenoid versions allow these units to be interfaced with CNC controls or other signaling devices. The pressurized delivery system of the MD - 1200, provides instant on-off performance when used with the solenoid control. Control module versions replace the air and liquid controls at the unit with controls located at the nozzle. This allows the operator to easily adjust the air and liquid setting in toolroom applications.



FEATURES:

- Available in 18" flexible plastic nozzle or 13" flexible copper nozzle.
- 6 Foot plastic delivery lines.
- Auto electric models come with a 120 VAC Solenoid.
- Size - 7.06"H x 10.09"W x 7.06"D.

Nozzle Type	No. of Lines	Control Module	Control Mode	Order No.	Price
Plastic	1	No	Manual	9930801	
Plastic	2	No	Manual	930802	
Plastic	1	No	Auto	30805	
Plastic	2	No	Auto	9930806	
Copper	1	No	Manual	30813	
Copper	2	Yes	Manual	30814	
Copper	2	Yes	Manual	30816	
Copper	1	No	Auto	30817	
Copper	2	No	Auto	30818	

MICRO-DROP® LUBRICANT

These environmentally safe lubricants can be used in nearly all machining applications. With the use of the Micro-Drop dispensing system, more effective machining productivity and savings in fluid costs can be achieved.



Both vegetable and synthetic lubricants can be used in many applications and with all metals. Vegetable lubricant performs more efficiently in high demanding machine operations because of its high lubricity and clinging power. The synthetic lubricant works in most applications where the depth of cut is not great.

Size	Synthetic Heavy Duty		Vegetable "NDF"	
	Order No.	Price	Order No.	Price
Gallons - 4/Case	306591		9306481	
5 Gallon Pail	30662		30647	
4oz. Squeeze Bottle -12/case	-		30678	



MACHINE TOOL COOLANT UNITS SERIES 708:

Little Giant "Flood Type" Machine Tool Coolant Units are designed for use with virtually any machine tool operational need. Units are engineered so that the flow of coolant liquids can be regulated to desired amount or completely shut off without harmful affects to the motor.



Model VMC - 1

Order No 560610	Price	
-----------------	-------	--

For use on small drill presses, tool grinders, tapping machines and small lathe equipment. Includes one gallon plastic tank, with screen and chip collector, tubing, flow rate nozzle, and pump with fan-cooled motor. 4' power cord with 3-prong molded plug. Thermally protected. 108 GPH.*

*GPH rate shown with Nozzle in place. 420 GPH without Nozzle.

SPECIFICATIONS:

115 Volt, 1/50 H.P., 1 Amp., 80 Watt.

DIMENSIONS:

9-1/4 H x 12 L x 6 W, 6 lbs.

Model MCT-5P

Order No 560040	Price	
-----------------	-------	--

For use on single-spindle drill presses, bench mills, tool grinders, single-spindle tapping machines, cut off saws, small lathes using water soluble or light cutting oil. Includes five gallon polyethylene tank, metal chip collector basket, baffle, 6' plastic hose, plastic flex nozzle and brass control valve, and all adapters and fittings for use with recommended pumps. (See Recommended Pump List below).

DIMENSIONS:

8 H x 10-15/16 L x 16-9/16 W, 19 lbs.

NOTE:

This unit does not include pump. Pump must be purchased in addition to MCT-5P Unit.

Model MCT-10

Order No 560300	Price	
-----------------	-------	--

For use with medium size lathes, grinders, cut off machines, milling and drilling machines using water soluble or light cutting oil. Includes ten gallon metal tank with baffle, 4' neoprene hose with brass nuts, plastic flex nozzle and brass control valve. Removable chip collector tray and splash deflector, plus all adapters and fittings for use with recommended pumps. (See Recommended Pump List below).

DIMENSIONS:

11-3/8 H x 10L x 25 H, 31 lbs.

NOTE:

This unit does not include pump. Pump must be purchased in addition to MCT-10 Unit.

RECOMMENDED PUMPS FOR UNITS: MCT-5P AND MCT-10 See chart below for pump specifications.

For MCT Unit	Pump Model No.	Pump Catalog No.	G.P.H. Water Soluble Oil					G.P.H. 100 SSU/Cutting Oil					G.P.H. 300 SSU/Cutting Oil					
			1'	3'	6'	12'	Shut Off'	1'	3'	6'	12'	Shut Off'	1'	3'	6'	12'	Shut Off'	
MCT-5P	1-YS	501020	72	60	36		7.4	24	14	6		3.5						
MCT-5P	NK-1	526003	70	60	40		10.2	24	14	6		5.0						
MCT-5P	NK-2	527003	82	78	64		12.2	35	29	19		6.1						
MCT-5P	3E-12N	503103	127	123	113	89	22.4	89	86	79	62	16.8	70	65	60	47	15.7	
MCT-5P	4E-34N	504103	134	129	119	100	24.3	95	89	81	68	18.3	75	71	64	54	17.5	
MCT-10	3E-12N	503103	197	192	182	155	22.4	139	133	123	105	16.8	108	100	93	80	15.7	
MCT-10	4E-34N	504103	210	204	192	162	24.3	157	156	150	126	19.4	124	123	120	100	18.6	
MCT-10	5-MSP	505000	212	208	198	167	26.8	161	159	154	129	21.4	127	125	123	102	20.5	
MCT-10	6-CIM-R	506271	185	178	163	118	18.5	138	136	127	92	14.7	108	107	101	73	14.0	

PUMP SPECIFICATIONS

Pump Model No.	Volts	H.P.	AMP/WATT	Weight	Dimensions (HxLxW)	Pump Order No.	Price
1-YS	115	1/150	1.1/70	3.4	4-1/4 x 4-1/8 Dia.	501020	
NK-1	115	1/150	1.1/70	3.4	4-9/16 x 4-1/8 Dia.	526003	
NK-2	115	1/40	1.7/100	4.1	4-9/16 x 4-1/8 Dia.	527003	
3E-12N	115	1/15	3.2/200	8.3	5-1/2 x 7 x 4-1/2	503103	
4E-34N	115	1/12	3.5/210	10.1	5-1/2 x 7 x 4-1/2	504103	
5-MSP	115	1/6	5/380	8.25	7-3/4 x 6-1/16 x 4-5/16	505000	
6-CIM-R	115	3/10	9/720	16.5	7-1/4 x 9-1/2 x 7-1/4	506271	





COOLING SUPPLIES

SERIES 690:



COOLANT PUMPS AND TANKS

Expressly built for those jobs which circulate coolant liquids and cutting oils separating chips, grit and abrasives.

- 1 Phase, 60 Cycle
- Made in USA
- Complete less hose assembly which can be ordered separately.
- 1/20 H.P. - recommended for soluble oil and lightweight cutting oil only.
- 1/3 H.P. and larger - recommended for all general purposes.



Model No.	Voltage	Motor H.P.	Tank Size	Tank Dimensions	Motor Height	GPM** 5ft.Hd.	Order No.	Price
521*	115	1/20	5 gal.	12 Dia. x 13 H	5 in.	6	6900521	
1021	115	1/20	10 gal.	24 L x 12.5 W x 9.5 H	5 in.	6	6901021	
1025	115/220	1/3	10 gal.	24 L x 12.5 W x 9.5 H	8 in.	16	6901025	
1030	115/220	1/3	20 gal.	30 L x 16 W x 10 H	8 in.	16	6901030	
1035	115/220	1/2	20 gal.	30 L x 16 W x 10 H	8 in.	24	6901035	
1040	115/220	1/2	36 gal.	36 L x 18 W x 13 H	8 in.	24	6901040	

* Round ** Gallons per minute.

HOSE ASSEMBLY

Includes: 4 ft. neoprene hose, valve, 15 in. flex hose with nozzle

Description	Order No.	Price
Complete	6900001	
Flex Hose & Valve only	6900002	
Hose only	6900003	

COOLANT PUMPS

- Pump and motor only.
- For replacement of old units or for use in building your own unit.

Model No.	Motor H.P.	Voltage	Pump Depth	GPM** 5 ft. Hd.	Order No.	Price
1022	1/20	115	5	6	6901022	
1023	1/20	115	8	6	6901023	
1026	1/3	115/220	8	16	6901026	
1027	1/2	115/220	8	24	6901027	

**Gallons per minute



MAGNETIC ADJUSTABLE HOLDER

For locating and holding nozzle in any position. Use with either liquid or mist systems.



Order No. 6900150	Price

MIST COOLANT SYSTEMS

- All with metal lines.

The heat of the tool and the part is more rapidly and thoroughly dissipated because a sprayed coolant mist exposes a greater fluid surface area and is thus capable of absorbing more heat faster. This extends tool life for lower costs per part.



SINGLE CONTROL UNITS

Model No.	Description	Order No.	Price
10	1 gal. plastic container, 1 outlet	6901010	
20	1 gal. plastic container, 2 outlets	6901020	

DUAL CONTROL UNITS

Model No.	Description	Order No.	Price
90	1 gal. plastic container, 1 outlet	6900090	
92	1 gal. plastic container, 2 outlets	6900092	
100S	1 gal. stainless tank, 1 outlet	6900100	
102S	1 gal. stainless tank, 2 outlets	6900102	
350C	3.5 gal. metal tank, 1 outlet	6900350	
352C	3.5 gal. metal tank, 2 outlets	6900352	

MIST COOLANT FLUID: M-16

Specially Concentrated :

- Increases tool life
- No-fogging — odorless
- For machining and tapping
- Contains rust preventative

Container Size*	Standard Package	Order No.	Price
1 Gallon	4 / case	6903010	

* Larger container sizes available; please inquire.



LINE ASSEMBLY

Description	Order No.	Price
4 ft. metal hose 45° nozzle	6900011 6900013	



MAGNETIC BASE COOLANT HOSE SYSTEMS

SERIES 221:

- Quickly attach to any metallic surface.
- Strong holding power.
- 1/4" dia. flexible coolant hoses attached to on-off magnetic base.

No. & Length of Coolant Hoses	Base Size	Order No.	Price
1 x 14"	2-3/4 x 2 x 2-7/8"	2390114	
2 x 14"	2-3/4 x 2 x 2-7/8"	2390214	
3 x 15"	2-3/4 x 2 x 2-7/8"	2390315	



INDUSTRIAL SUPPLIES

AQUAFLO®

SERIES 986:



FLEXBAR



COOLANT DISPENSER

Deluxe water-soluble oil dispensers enable you to take even heavy cuts such as in "flycutting". Compact in size, one-knob control instantly starts up and shuts down the nozzle. Spray settles on cutting tool and workpiece; will not clog or fog up your plant. Minimum air pressure 25 PSI with Maximum 80 PSI. Built to last.

SINGLE AQUAFLO®

Single coolant nozzle comes with bracket for fast attachment on to any 1/4" dia. fitting on your machine tool. Supplied with 2 each 4 foot length lines; one NPT fitting air line and one suction hose line. Works with any coolant container (not included).

Model No. 14014

Order No. 8614014	Price:	
-------------------	--------	--

CUTTING FLUID APPLICATOR

SERIES 79:

NOGA



MINICOOL - for maximum heat dissipation and extended tool life.

- Strong magnetic base
- Separate on/off and fluid controls
- Stainless steel armored siphon hose and air hose
- Nozzle connected via LOC-LINE flexible hose
- Simple, inexpensive, rugged

Order No. 9861700	Price:	
-------------------	--------	--



While we show only the most popular **FLEXBAR** items we can supply their entire range of products; please inquire.

THE ORIGINAL MODULAR HOSE SYSTEM

SERIES 692:

LOC-LINE®
MODULAR HOSE SYSTEM



- Accurately aim coolant flow and many other applications.
- Repeated positioning is easy and it will stay in position without any springback.
- Chemically resistant to petroleum products, coolants and most common chemicals. (also available in acid resistant polyester).
- Electrically non-conductive.
- Designed for low pressure applications.

The following specifications are guidelines for all Loc-Line® coolant hose systems:

LINE PRESSURE & FLOW RATES:

1/4" System 30-50PSI 250 Gal./Hr.

1/2" System 20-30PSI 478 Gal./Hr.

3/4" System 10-20PSI 1,140 Gal./Hr.

- Temperature specifications are as follows:
Melting point 329°F
Maximum operating temperature: 170°F

(Continued)





THE ORIGINAL MODULAR HOSE SYSTEM



1/4" SYSTEM • 1/4" INSIDE DIAMETER

SERIES 692:

	<p>1/4" Hose Kit 13" Length with Fittings: 2 - 5-3/4" Segments 1/4", 1/8", 1/16" Nozzles 1/4" & 1/8" Male NPT Connectors Order No. 9240413 Price: <input type="text"/></p>
	<p>1/4" Flared Tubing Replacement Pack: 8 - 5-3/4" Segments 1 - 1" Flare Nozzle Includes 4 ea. of: 3/8" Flare Nut Adapters 1/8" Round Nozzles 1/4" Round Nozzles Order No. 9240452 Price: <input type="text"/></p>
	<p>1/4" 90° Nozzle Kit: 1 ea. 1/16", 1/8", 1/4" & 1/4" Spray Bar Nozzles Order No. 9241474 Price: <input type="text"/></p>
	<p>1/4" Extended Element Kit with Element Clamps, Includes 4 ea. of: 1/4" Extended Elements 1/4" Element Clamps Order No. 9241475 Price: <input type="text"/></p>
	<p>1/4" Circle Flow Nozzle Kit Assembled with 15 Side Flow Nozzles 1/4", & 1 End Cap 1/4" Order No. 9241479 Price: <input type="text"/></p>
	<p>1/4" Segment Pack (2-5-3/4" pcs.) Order No. 9241401 Price: <input type="text"/> 1/4" Segment Pack Bulk 25 ft. Order No. 9249420 Price: <input type="text"/> 1/4" Segment 50 ft. Coil. Order No. 9241421 Price: <input type="text"/></p>
	<p>1/4" Extended Elements, Pack of 4 Order No. 9241476 Price: <input type="text"/> Pack of 20 Order No. 9249445 Price: <input type="text"/></p>
	<p>1/4" Element Clamp, Pack of 4 Order No. 9241477 Price: <input type="text"/> Pack of 20 Order No. 9249446 Price: <input type="text"/></p>
	<p>1/16" Round Nozzles, Pack of 4 Order No. 9241402 Price: <input type="text"/> Pack of 50 Order No. 9249422 Price: <input type="text"/></p>

	<p>1/8" Round Nozzles, Pack of 4 Order No. 9241403 Price: <input type="text"/> Pack of 50 Order No. 9249423 Price: <input type="text"/></p>
	<p>1/4" Round Nozzles, Pack of 4 Order No. 9241404 Price: <input type="text"/> Pack of 50 Order No. 9249424 Price: <input type="text"/></p>
	<p>1/16" 90° Nozzles, Pack of 4 Order No. 9241470 Price: <input type="text"/> Pack of 20 Order No. 9249439 Price: <input type="text"/></p>
	<p>1/8" 90° Nozzles, Pack of 4 Order No. 9241471 Price: <input type="text"/> Pack of 20 Order No. 9249440 Price: <input type="text"/></p>
	<p>1/4" 90° Nozzles, Pack of 4 Order No. 9241472 Price: <input type="text"/> Pack of 20 Order No. 9249441 Price: <input type="text"/></p>
	<p>1/4" 90° Spray Bar Nozzles, Pack of 2 Order No. 9241473 Price: <input type="text"/> Pack of 20 Order No. 9249442 Price: <input type="text"/></p>
	<p>1" Flare Nozzles, Pack of 2 Order No. 9241407 Price: <input type="text"/> Pack of 20 Order No. 9249427 Price: <input type="text"/></p>
	<p>1/8" NPT Connectors, Pack of 4 Order No. 9241405 Price: <input type="text"/> Pack of 50 Order No. 9249425 Price: <input type="text"/></p>
	<p>1/8" BSPT* Connectors, Pack of 4 Order No. 9241417 Price: <input type="text"/> Pack of 50 Order No. 9249437 Price: <input type="text"/> *British Standard Pipe Thread</p>
	<p>1/4" NPT Connectors, Pack of 4 Order No. 9241406 Price: <input type="text"/> Pack of 50 Order No. 9249426 Price: <input type="text"/></p>
	<p>1/4" BSPT* Connectors, Pack of 4 Order No. 9241418 Price: <input type="text"/> Pack of 50 Order No. 9249438 Price: <input type="text"/> * British Standard Pipe Thread</p>

	<p>1/4" Y Fittings, Pack of 2 Order No. 9241408 Price: <input type="text"/> Pack of 20 Order No. 9249428 Price: <input type="text"/></p>
	<p>1/4" Double Sockets, Pack of 4 Order No. 9241409 Price: <input type="text"/> Pack of 20 Order No. 9249429 Price: <input type="text"/></p>
	<p>1/4" Socket to 1/8" FNPT, Pack of 4 Order No. 9241411 Price: <input type="text"/> Pack of 20 Order No. 9249431 Price: <input type="text"/></p>
	<p>3/8" SAE Flare Nut Adapters, Pack of 4 Order No. 9241412 Price: <input type="text"/> Pack of 20 Order No. 9249432 Price: <input type="text"/> (5/8-18 Thread)</p>
	<p>1/4" SAE Flare Nut Adapters, Pack of 4 Order No. 9241414 Price: <input type="text"/> Pack of 20 Order No. 9249434 Price: <input type="text"/> (7/16-20 Thread)</p>
	<p>1/4" Elbow Fittings, Pack of 2 Order No. 9241415 Price: <input type="text"/> Pack of 20 Order No. 9249435 Price: <input type="text"/></p>
	<p>1/4" T Fittings, Pack of 2 Order No. 9241416 Price: <input type="text"/> Pack of 20 Order No. 9249436 Price: <input type="text"/></p>
	<p>1/4" Side Flow Nozzles, Pack of 4 Order No. 9241478 Price: <input type="text"/> Pack of 20 Order No. 9249443 Price: <input type="text"/></p>
	<p>1/4" End Caps, Pack of 4 Order No. 9241480 Price: <input type="text"/> Pack of 20 Order No. 9249447 Price: <input type="text"/></p>
	<p>1/4" Swivel Nozzle 40, Pack of 2 Order No. 9241481 Price: <input type="text"/> Pack of 20 Order No. 9249449 Price: <input type="text"/></p>
	<p>1/4" Swivel Nozzle 60, Pack of 2 Order No. 9241482 Price: <input type="text"/> Pack of 20 Order No. 9249450 Price: <input type="text"/></p>

INDUSTRIAL SUPPLIES

MACHINE SHOP DISCOUNT SUPPLY

THE ORIGINAL MODULAR HOSE SYSTEM

SERIES 692:



LOC-LINE®
MODULAR HOSE SYSTEM



INDUSTRIAL SUPPLIES

1/4" SYSTEM • 1/4" INSIDE DIAMETER (Continued)

	1/4" In-Line Check Valves Pack of 2 Order No. 9221191 Price: <input type="text"/> Pack of 10 Order No. 9229451 Price: <input type="text"/>
	1/4" Male NPT Valves Pack of 2: Order No. 9221192 Price: <input type="text"/> Pack of 10 Order No. 9229452 Price: <input type="text"/>
	1/4" Female NPT Valves Pack of 2 Order No. 9221193 Price: <input type="text"/> Pack of 10 Order No. 9229453 Price: <input type="text"/>
	1/4" In-Line Valves Pack of 2 Order No. 9221194 Price: <input type="text"/> Pack of 10 Order No. 9229454 Price: <input type="text"/>
	1/4" Flat Slot 40 Nozzle Pack of 4 Order No. 9241483 Price: <input type="text"/> Pack of 20 Order No. 9249451 Price: <input type="text"/>
	1/4" Flat Slot 60 Nozzle Pack of 4 Order No. 9241484 Price: <input type="text"/> Pack of 20 Order No. 9249452 Price: <input type="text"/>
	1/4" Flat 5 Hole Nozzle Pack of 4 Order No. 9241485 Price: <input type="text"/> Pack of 20 Order No. 9249453 Price: <input type="text"/>
	1/4" Flat 7 Hole Nozzle Pack of 4 Order No. 9241486 Price: <input type="text"/> Pack of 20 Order No. 9249454 Price: <input type="text"/>
	1/4" Flat Nozzle Assortment Pack: 1/4" Flat Slot 40 Nozzle - 1pc. 1/4" Flat Slot 60 Nozzle - 1pc. 1/4" Flat 5 Hole Nozzle - 1pc. 1/4" Flat 7 Hole Nozzle - 1pc. Order No. 9241487 Price: <input type="text"/>
	Hose Assembly Pliers 1/4" Order No. 9278001 Price: <input type="text"/> 1/4" & 1/2" Plier Set Order No. 9278003 Price: <input type="text"/>

1/2" SYSTEM • 1/2" INSIDE DIAMETER

	1/2" Hose Kit 13" Length with Fittings: 2 -5-1/2" Segments 1/4", 3/8", 1/2" Nozzles 3/8" & 1/2" Male NPT Connectors Order No. 9250813 Price: <input type="text"/>
	90° Nozzle Kit: 1 ea. 1/4", 3/8", 1/2" & Spray Bar Nozzles Order No. 9251832 Price: <input type="text"/>
	1/2" Extended Element Kit with Element Clamps Includes 4 ea. of: 1/2" Extended Elements 1/2" Element Clamps Order No. 9251835 Price: <input type="text"/>
	1/2" Circle Flow Nozzle Kit: Assembled with 15 Side Flow Nozzles 1/2" & 1 End Cap 1/2" Order No. 9251837 Price: <input type="text"/>
	1/2" Segment Pack (2-5-1/2" pcs.) Order No. 9251801 Price: <input type="text"/> 1/2" Segment Pack Bulk 25 ft. Order No. 9259860 Price: <input type="text"/> 1/2" Segment 50 ft. Coil Order No. 9259861 Price: <input type="text"/>
	1/2" Extended Elements Pack of 4 Order No. 9251833 Price: <input type="text"/> Pack of 20 Order No. 9259883 Price: <input type="text"/>
	1/2" Element Clamps Pack of 4 Order No. 9251834 Price: <input type="text"/> Pack of 20 Order No. 9259884 Price: <input type="text"/>
	1/4" Round Nozzles Pack of 4 Order No. 9251806 Price: <input type="text"/> Pack of 50 Order No. 9259866 Price: <input type="text"/>
	3/8" Round Nozzles Pack of 4 Order No. 9251802 Price: <input type="text"/> Pack of 50 Order No. 9259862 Price: <input type="text"/>

	1/2" Round Nozzles Pack of 4 Order No. 9251803 Price: <input type="text"/> Pack of 50 Order No. 9259863 Price: <input type="text"/>
	1/4" 90° Nozzles Pack of 4 Order No. 9251828 Price: <input type="text"/> Pack of 20 Order No. 9259878 Price: <input type="text"/>
	3/8" 90° Nozzles Pack of 4 Order No. 9251829 Price: <input type="text"/> Pack of 20 Order No. 9259879 Price: <input type="text"/>
	1/2" 90° Nozzles Pack of 4 Order No. 9251830 Price: <input type="text"/> Pack of 20 Order No. 9259880 Price: <input type="text"/>
	1/2" 90° Spray Bar Nozzles Pack of 2 Order No. 9251831 Price: <input type="text"/> Pack of 20 Order No. 9259881 Price: <input type="text"/>
	1-1/4" Flare Nozzles Pack of 2 Order No. 9251807 Price: <input type="text"/> Pack of 20 Order No. 9259867 Price: <input type="text"/>
	2-1/2" Flare Nozzles Pack of 2 Order No. 9251809 Price: <input type="text"/> Pack of 20 Order No. 9259871 Price: <input type="text"/>
	3/8" NPT Connectors Pack of 4 Order No. 9251804 Price: <input type="text"/> Pack of 50 Order No. 9259864 Price: <input type="text"/>
	3/8" BSPT* Connectors Pack of 4 Order No. 9251826 Price: <input type="text"/> Pack of 50 Order No. 9259876 Price: <input type="text"/> *British Standard



(Continued)



THE ORIGINAL MODULAR HOSE SYSTEM

SERIES 692:



1/2" SYSTEM • 1/2" INSIDE DIAMETER (Continued)

	1/2" NPT Connectors Pack of 4 Order No. 9251805 Price: <input type="text"/> Pack of 50 Order No. 9259865 Price: <input type="text"/>
	1/2" BSPT* Connectors Pack of 4 Order No. 9251827 Price: <input type="text"/> Pack of 50 Order No. 9259877 Price: <input type="text"/> *British Standard Pipe Thread
	1/2" Y Fittings Pack of 2 Order No. 9251808 Price: <input type="text"/> Pack of 20 Order No. 9259868 Price: <input type="text"/>
	1/2" to 1/4" Y Reducers Pack of 2 Order No. 9251822 Price: <input type="text"/> Pack of 20 Order No. 9259870 Price: <input type="text"/>
	1/2" to 1/4" Adapters Pack of 2 Order No. 9251821 Price: <input type="text"/> Pack of 20 Order No. 9259869 Price: <input type="text"/>
	1/2" Double Sockets Pack of 4 Order No. 9251811 Price: <input type="text"/> Pack of 20 Order No. 9259872 Price: <input type="text"/>
	3/8" SAE Flare Nut Adapters Pack of 4 Order No. 9251823 Price: <input type="text"/> Pack of 20 Order No. 9259873 Price: <input type="text"/> (5/8-18)
	1/2" Elbow Fittings Pack of 2 Order No. 9251824 Price: <input type="text"/> Pack of 20 Order No. 9259874 Price: <input type="text"/>
	1/2" T Fittings Pack of 2 Order No. 9251825 Price: <input type="text"/> Pack of 20 Order No. 9259875 Price: <input type="text"/>
	1/2" Side Flow Nozzle Pack of 4 Order No. 9251836 Price: <input type="text"/> Pack of 20 Order No. 9259889 Price: <input type="text"/>

	1/2" End Caps Pack of 4 Order No. 9251838 Price: <input type="text"/> Pack of 20 Order No. 9259885 Price: <input type="text"/>
	1/2" In-Line Check Valves Pack of 2: Order No. 9232091 Price: <input type="text"/> Pack of 10 Order No. 9239851 Price: <input type="text"/>
	1/2" Male NPT Valves Pack of 2 Order No. 9232092 Price: <input type="text"/> Pack of 10 Order No. 9239852 Price: <input type="text"/>
	1/2" Female NPT Valves Pack of 2 Order No. 9232093 Price: <input type="text"/> Pack of 10 Order No. 9239853 Price: <input type="text"/>
	1/2" In-Line Valves Pack of 2 Order No. 9232094 Price: <input type="text"/> Pack of 10 Order No. 9239854 Price: <input type="text"/>
	1/2" Flat Slot 80* Nozzle Pack of 4 Order No. 9251840 Price: <input type="text"/> Pack of 20 Order No. 9259890 Price: <input type="text"/> * Slot Height .080"
	1/2" Flat Slot 125* Nozzle Pack of 4 Order No. 9251841 Price: <input type="text"/> Pack of 20 Order No. 9259891 Price: <input type="text"/> * Slot Height .125"
	1/2" Flat 5 Hole Nozzle Pack of 4 Order No. 9251842 Price: <input type="text"/> Pack of 20 Order No. 9259892 Price: <input type="text"/> .125 Hole Diameter
	1/2" Flat 7 Hole Nozzle Pack of 4 Order No. 9251843 Price: <input type="text"/> Pack of 20 Order No. 9259893 Price: <input type="text"/> .080 Hole Diameter
	1/2" Flat Nozzle Assortment Pack: Contains 1 each 1/2" Flat Slot 80 Nozzle 1/2" Flat Slot 125 Nozzle 1/2" Flat 5 Hole Nozzle 1/2" Flat 7 Hole Nozzle Order No. 9251844 Price: <input type="text"/>

	1/2" Hose Assembly Pliers Order No. 9278002 Price: <input type="text"/>
	1/4" & 1/2" Plier Set Order No. 9278003 Price: <input type="text"/>



3/4" SYSTEM • 3/4" INSIDE DIAMETER

	3/4" Hose Kit: 14" Length with Fittings: 2 - 5-3/4" Segments 5/8, 3/4" Nozzles 3/4" Male NPT Connector Order No. 9260513 Price: <input type="text"/>
	3/4" Segment Pack (2-5-3/4" pcs) Order No. 9261501 Price: <input type="text"/> 3/4" Segment Pack Bulk 25 Ft. Order No. 9269540 Price: <input type="text"/> 3/4" Segment 50 Ft. Coil Order No. 9269541 Price: <input type="text"/>
	5/8" Round Nozzles Pack of 4 Order No. 9261503 Price: <input type="text"/> Pack of 50 Order No. 9269543 Price: <input type="text"/>
	3/4" Round Nozzles Pack of 4 Order No. 9261502 Price: <input type="text"/> Pack of 50 Order No. 9269542 Price: <input type="text"/>
	3" Flare Nozzles Pack of 2 Order No. 9261507 Price: <input type="text"/> Pack of 20 Order No. 9269547 Price: <input type="text"/>
	3/4" NPT Connectors Pack of 4 Order No. 9261505 Price: <input type="text"/> Pack of 50 Order No. 9269545 Price: <input type="text"/>

INDUSTRIAL SUPPLIES













LOC-LINE®
VACUUM HOSE SYSTEM

LOC-LINE®
VACUUM HOSE SYSTEM



3/4" SYSTEM • 3/4" INSIDE DIAMETER

	3/4" BSPT* Connectors Pack of 4 Order No. 9261509 Price: <input type="text"/> Pack of 50 Order No. 9269549 Price: <input type="text"/> *British Standard Pipe Thread
	3/4" Y Fittings Pack of 2 Order No. 9261511 Price: <input type="text"/> Pack of 20 Order No. 9269551 Price: <input type="text"/>
	3/4" to 1/2" Y Reducers Pack of 2 Order No. 9261512 Price: <input type="text"/> Pack of 20 Order No. 9269552 Price: <input type="text"/>
	3/4" to 1/2" Adapters Pack of 2 Order No. 9261508 Price: <input type="text"/> Pack of 20 Order No. 9269548 Price: <input type="text"/>
	3/4" Double Sockets Pack of 4 Order No. 9261514 Price: <input type="text"/> Pack of 20 Order No. 9269554 Price: <input type="text"/>
	6" x 8" Quick Set Shield Kit™ Order No. 9260525 Price: <input type="text"/> 7-1/2" x 10" Quick Set Shield Kit™ Order No. 9260526 Price: <input type="text"/> 8-1/2" x 12" Quick Set Shield Kit™ Order No. 9260527 Price: <input type="text"/> All Quick-set Shield Kits include a 14" adjustable 3/4" Loc-Line® arm, magnetic base and fitting for fixed mounting.
	6" x 8" Replacement Shield Order No. 9260528 Price: <input type="text"/> 7-1/2" x 10" Replacement Shield Order No. 9260529 Price: <input type="text"/> 8-1/2" x 12" Replacement Shield Order No. 9260530 Price: <input type="text"/>
	Shield Mounting Elbows Pack of 2 Order No. 9260531 Price: <input type="text"/>
	3/4" Magnetic Base Order No. 9260532 Price: <input type="text"/>
	3/4" Fixed Mounts Pack of 2 Order No. 9260533 Price: <input type="text"/>
	3/4" Hose Assembly Pliers Order No. 9278004 Price: <input type="text"/>

MODULAR & ADJUSTABLE VACUUM HOSE

Designed to be added to an existing central vacuum system to extract smoke, dust, fumes and particles at the source.







Applications: Soldering, wet grinding, machining applications, (especially mist, graphite, and particles), chemical odors and fumes (except acids)



Melting point 329°F • Maximum operating temperature 170°F

- Hand adjustable 360°
- Self supporting up to 3'.
- Durable, will not fray.
- Resistant to most chemicals.
- Bending radius of 5.75".



	Order No.	Description	Price
	9281201 9281202 9289220	9 elements 2.5" ID (1 foot segment) 18 elements 2.5" ID (2 - one foot segments) 180 elements 2.5" ID (20 - one foot segments)	
	9281203 9289223	4.5" Round Nozzle - 1 pc. 4.5" Round Nozzle - 10 pcs.	
	9281204 9289224	6" x 3.5" Rectangular Nozzle - 1 pc. 6" x 3.5" Rectangular Nozzle - 10 pcs.	
	9281205 9289225	Tapered Oval Nozzle - 1 pc. Tapered Oval Nozzle - 10 pcs.	
	9281206 9289226	3" Loc-Line PVC Adapter - 1 pc. 3" Loc-Line PVC Adapter - 10 pcs.	
	9281207 9289227	3" Loc-Line Sheet Metal Duct Adapter - 1 pc. 3" Loc-Line Sheet Metal Duct Adapter - 10 pcs.	

Caution: Loc-Line® Vacuum Hose is made from an acetal copolymer. This material is not fire retardant and thus would pose a fire hazard if the material is subjected to an application where high temperatures or flames exist.



Other **LOC-LINE®** products available:

- Modular Manifolds
 - Acid Resistant Hoses
- Please inquire.**



VAC AND COLD AIR COOLANT SYSTEMS



SERIES 225:

Cold Gun Air Coolant System



Replace messy mist systems and improve dry machining with cold air. The Cold Gun Aircoolant System produces a stream of clean cold air at 50°F (28°C) below supply air temperature. It will remove heat to prolong tool life and increase productivity on machining operations when liquid coolants cannot be used.

EXAIR's Cold Gun is non-adjustable to prevent freeze-up during use. Cold airflow and temperature drop are factory set to optimize the gun's cooling capability for continuous use.

The Adjustable Spot Cooler offers precise temperature settings from -30°F to room temperature with the simple turn of a knob (freezing possible). A swivel magnetic base provides easy mounting and portability.

Model 5215 Single Point Cold Gun System is recommended for grinding and drilling operations.

Model 5315 Dual Point Cold Gun System is ideal for larger surface areas such as milling or sawing.

Model 3825 Adjustable Spot Cooler System can be used in the applications listed when **continuous use** at temperatures below 20°F are not required.

Order No.	Description	Price
5215	Single Point Cold Gun System (Includes magnetic base, hose kit and filter.)	
5315	Dual Point Cold Gun System (Includes magnetic base, hose kit and filter.)	
3825	Adjustable Spot Cooler System includes swivel magnetic base, filter, (2) additional generators and single point hose kit with cone and fan nozzle.	
9003	Manual Drain Filter Separator, 1/4 NPT	
9012	Manual Shutoff Valve, 1/4 NPT	

Applications:

- Tool sharpening
- Drill & cutter grinding
- Routing
- Plunge and form grinding
- Milling
- Surface grinding
- Drilling
- Tire grinding
- Band sawing
- Plastic machining

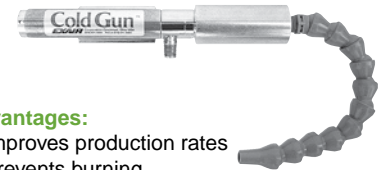

Advantages:

- Improves production rates
- Prevents burning
- Extends tool life - reduces breakage
- Improves tolerance control
- Prevents smearing of metal or plastics
- Maintenance free - no moving parts
- Quiet (less than 75 dBA)

Chip Vac System



EXAIR's compressed air operated Chip Vac is an industrial duty vacuum designed specifically for vacuuming chips. It creates a powerful cyclonic action that vacuums metal, wood or plastic chips into an ordinary 55 gallon drum. Dusty materials such as absorbents are trapped by the 0.1 micron filter bag to keep the surrounding air clean.

- Powerful cyclonic action
- No moving parts - maintenance free
- Quieter than electric vacuums
- No motors to clog or wear out
- Dust free-chips go directly into drum
- Includes all accessories



Order No.	Description	Price
6193	Chip Vac System includes the Chip Vac, lever lock drum lid, shutoff valve, filter bag, 10' chemical resistant hose (1.5" I.D.), chip wand, extensions, crevice tool, brush, skimmer and floor tool (drum not included).	
9001	Auto Drain Filter Separator, 1/4 NPT, 73 SCFM	

Pick up wet or dry chips from fixtures, floors and work surfaces of machining centers, lathes, saws, mills or other industrial equipment and deliver them directly to an ordinary 55 gallon drum.

Reversible Drum Vac System

The Reversible Drum Vac is a safe, maintenance free way to recover:

- Coolant
- Hydraulic oils
- Liquid spills
- Sludge and chips
- Tramp oil
- Waste water



EXAIR's compressed air operated Reversible Drum Vac System attaches quickly to any closed head 55 gallon drum. Its high powered vacuum fills the drum in less than two minutes. With the simple turn of a knob, the same stainless steel pump quickly empties the drum. Coolant sumps can be easily refilled, floor spills vacuumed, or contaminated liquids transferred to filtration tanks in minutes.

Electrically operated "all purpose" vacuums aren't designed for use in industrial environments. As a result, motors wear out quickly and impellers clog. The Reversible Drum Vac does not use electricity and has no moving parts, assuring maintenance free operation. An automatic safety shutoff valve prevents spills or overfilling.



Model 6901 Spill Recovery Kit.

Order No.	Description	Price
6191	Reversible Drum Vac System includes two-way pump assembly (1/4 NPT), shutoff valve, 10' flexible vacuum hose (1.5" I.D.) with 90° quick release elbow connection, (2) extension wands, crevice tool, skimmer tool and floor tool (drum not included).	
6901	Spill Recovery Kit includes a one-piece 54" ABS wand and 14" double blade squeegee tool.	
9001	Auto Drain Filter Separator, 1/4 NPT, 73 SCFM	

PNEUVAC GUNS SERIES 450:



STANDARD

- Unique design enables unit to act as both a blow gun and a vacuum.
- High-output venturi design multiplies air flow by 12 times. For example, an input air supply of 10 cfm results in an output of 120 cfm.
- Changing between blow and vacuum modes is accomplished by simply reversing the direction of the venturi.
- New trigger design reduces strain.
- High vacuum production with minimal air consumption.
- Made of rugged, anti-static nylon.

DEEPHOLE

For removing chips from blind holes up to 18" deep.

The deep hole gun is a modified version of the PneuVac gun, designed for removing chips from blind holes. The thin black tube blasts high pressure air to dislodge chips while the main nozzle draws them safely away. A clear plastic shroud protects the operator from flying debris.



Order No.	Description	Price
49005	PneuVac Gun Only	
49085	Dust Bag Kit: PneuVac Gun, dust bag, extension tube and clamp	
49080	Hose Kit: PneuVac Gun, 10ft. smooth-bore hose, extension tube and clamp	
49095	Accessory Kit: Two extension tubes, crevice tool, vacuum head, vacuum head brush and round brush	
49010	Deep Hole Gun Only	
49020	Dust Bag and Clamp Only	
49090	10ft Smooth Bore Hose Only	

PNEUVAC PUMP

The perfect way to clean coolant sumps.



The PneuVac pump is a simple device that uses a compressed air powered Venturi to create a vacuum. All you have to do to operate the unit is: attach the pump and hose to a standard 55-gallon drum, hook up your compressed air supply to the pump, insert the free end of the suction hose into the sump or storage tank and open the air valve. Designed to remove liquids, (and sludge and chips suspended in liquids) from:

- Lathes • Screw Machines • Grinders
- Machining Centers • Tanks
- EDM Machines • Spills
- Coolant Sumps
- Open Pits

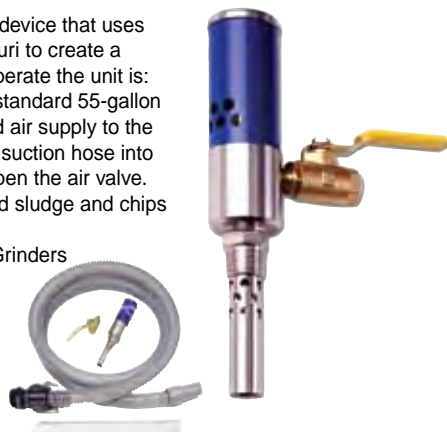

Caution:

1. Do not use the PneuVac pump with flammable or volatile liquids such as gasoline, alcohol, kerosene, aviation fuel, mineral spirits or any similar liquid with a low flash point.
2. Do not modify this product to pressurize drum to pump liquids out. Pressurizing drum could cause an explosion that might result in a serious injury.

PneuVac Pump Kit: Consists of pump, 1/4" ball valve, automatic shut-off valve, 10ft. of smooth-bore hose, quick-disconnect drum fittings, and one 18" aluminum wand.

Description	Order No.	Price
Stainless Steel Pump Kit	48010	
Aluminum Pump Kit	48017	
Replacement Hose 10 ft.	48019	



PISTOL VAC

SERIES 677:



Wherever powerful industrial vacuum cleaning is required. Pistol Vac connects directly to your air line and can be used for a wide range of industrial cleaning jobs in vacuum mode as well as blow mode.

Pistol Vac uses 14 CFM of shop-air at 85 PSI and has an air flow through gun of 115 CFM. To turn your vacuum gun into a very powerful air blowing tool, remove back of gun and reverse venturi so that small air flow arrow points forward.

- Made from heavy duty engineered polymer
- OSHA compliant in Blow Gun mode.
- Made in U.S.A.

Pistol Vac with Bag Kit

Kit includes:
Pistol Vac Tool #64016, Crevice tool, canvas dust bag, 1-1/4" x 3" hose and two #20 hose clamps.



Order No. 64000 Price:

ACCESSORIES

Item	Order No.	Price
Crevice Tool	64001	
Vacuum Bag	9964002	
Smooth Bore Hose/ft	64003	
Brush	64005	
20" Extension Tube	9964006	
2" Dia. Fitting for Steel Drum	64007	

HAND BLOWER

SERIES 442:



- Made of high quality rubber for long life.
- Special brass nozzle provides a strong, clean, air stream.
- For small air cleaning jobs, suck molten solder, drive out chips, sawdust from T slots, gears, etc.

Order No.	Approx. Lgth	Body Dia.	Price
4420027	4-1/2"/115mm	2-1/8"/54mm	



AIR HOSE
SERIES 959:



Neoprene Hose Assemblies

Able to withstand working pressures up to 300 psi and temperatures up to 180°F yet maintain flexibility.

Impervious to oil, gasoline, grease and solvents.



Neoprene Pigtail Assemblies

Extends the life of the coupler by acting as a shock absorber and protecting it against tool vibration.



Model No.	Hose Length	Hose ID	MPT Fitting	Order No.	Price Each
R14012	12'	1/4"	1/4"	24232	
R14025	25'	1/4"	1/4"	24239	
R14050	50'	1/4"	1/4"	24246	
R380124	12'	3/8"	1/4"	24330	
R380254	25'	3/8"	1/4"	9924344	
R380504	50'	3/8"	1/4"	24358	
R38012	12'	3/8"	3/8"	24323	
R38025	25'	3/8"	3/8"	24337	
R38050	50'	3/8"	3/8"	24351	

Model No.	Hose Length	Hose ID	MPT Fitting	Order No.	Price Each
RP0406	6"	1/4"	1/4"	25504	
RP0412	12"	1/4"	1/4"	25511	
RP0418	18"	1/4"	1/4"	25525	
RP0424	24"	1/4"	1/4"	25539	
RP0612	12"	3/8"	3/8"	25595	
RP0618	18"	3/8"	3/8"	25609	
RP0624	24"	3/8"	3/8"	25623	

Flexeel Inner - Braided Polyurethane Hose

200 psi working pressure.

Extremely flexible even in subzero temperatures.



Flexeel Lead-in Hose Assemblies with Ball Swivel Fittings

Prolongs hose life by eliminating end stress and increases production by facilitating tool manipulation.



Use between the air hose and the coupler.

Model No.	Hose Length	Hose ID	MPT Fitting	Order No.	Price Each
PFE40254T	25'	1/4"	1/4"	9950312	
PFE40256T	25'	1/4"	3/8"	0050313	
PFE40504T	50'	1/4"	1/4"	9950314	
PFE40506T	50'	1/4"	3/8"	9950315	
PFE41004T	100'	1/4"	1/4"	9950316	
PFE41006T	100'	1/4"	3/8"	9950317	
PFE60254T	25'	3/8"	1/4"	0950321	
PFE60256T	25'	3/8"	3/8"	9950322	
PFE60504T	50'	3/8"	1/4"	9950323	
PFE60506T	50'	3/8"	3/8"	9950324	
PFE61004T	100'	3/8"	1/4"	9950325	
PFE61006T	100'	3/8"	3/8"	9950326	

Model No.	Hose Length	Hose ID	Male Ball Swivel x Female Rigid	Order No.	Price Each
FP0412BS	12"	1/4"	1/4" NPT	29600	
FP0418BS	18"	1/4"	1/4" NPT	29601	
FP0424BS	24"	1/4"	1/4" NPT	29602	
FP0430BS	30"	1/4"	1/4" NPT	29603	
FP0436BS	36"	1/4"	1/4" NPT	29604	
FP0460BS	60"	1/4"	1/4" NPT	29605	
FP06124BS	12"	3/8"	1/4" NPT	29612	
FP06184BS	18"	3/8"	1/4" NPT	29613	
FP06244BS	24"	3/8"	1/4" NPT	29614	
FP06304BS	30"	3/8"	1/4" NPT	29615	
FP06364BS	36"	3/8"	1/4" NPT	29616	
FP06604BS	60"	3/8"	1/4" NPT	29617	

Nylon 11 Self Storing Hose

Withstands temperatures between -60°F and +200°F. Highly flexible and lightweight.



Model No.	Hose Length	Hose ID	MPT Fitting	Order No.	Price Each
N14-12B	12'	1/4"	1/4" (2 SW)	27475	
N14-17B	17'	1/4"	1/4" (2 SW)	27503	
N14-25B	25'	1/4"	1/4" (2 SW)	27531	
N14-50B	50'	1/4"	1/4" (2 SW)	27559	
N38-12B	12'	3/8"	3/8" (2 SW)	27678	
N38-17B	17'	3/8"	3/8" (2 SW)	27727	
N38-25B	25'	3/8"	3/8" (2 SW)	27776	
N38-50B	50'	3/8"	3/8" (2 SW)	27825	

Flexcoil Polyurethane Self Storing Hose

Kink and abrasion resistant. Lightweight and extremely durable.



Model No.	Hose Length	Hose ID	MPT Fitting	Order No.	Price Each
PU14-10B-B	10'	1/4"	1/4"	48022	
PU14-20B-B	20'	1/4"	1/4"	48102	
PU14-25B-B	25'	1/4"	1/4"	48142	
PU14-50B-B	50'	1/4"	1/4"	48402	
PU38-10B-B	10'	3/8"	3/8"	48942	
PU38-20B-B	20'	3/8"	3/8"	49062	
PU38-25B-B	25'	3/8"	3/8"	49122	
PU38-50B-B	50'	3/8"	3/8"	49442	

MACHINE SHOP DISCOUNT SUPPLY

BLOW GUNS

SERIES 959:



Standard Safety Tip Lever Operated Blow Gun



Ergonomically designed to fit the contour of the users' hand.

Model No.	Description	Order No.	Price Each
600S-DL	Safety Tip	9913123	

Tamperproof Safety Lever Operated Blow Gun



Features a tip that is permanently attached to the body assuring OSHA Compliance and user safety.

Model No.	Description	Order No.	Price Each
600ST-DL	Tamperproof Tip	9913205	

Extension Tip Safety Lever Operated Blow Gun



The ideal solution for longer reach into tight places.

Model No.	Description	Order No.	Price Each
603-S	3" Extension Tip	13179	
606-S	6" Extension Tip	13186	
612-S	12" Extension Tip	913207	
616-S	16" Extension Tip	13214	
624-S	24" Extension Tip	13228	
636-S	36" Extension Tip	13242	

Brass Tip Button Blow Gun



Ventless tip provides most economical means of achieving a concentrated air stream for many blow-off applications.

Model No.	Description	Order No.	Price Each
605	Brass Tip	9913172	

High Volume Safety Tip Pistol Grip Blow Gun



Designed to increase flow while reducing air consumption.

Model No.	Description	Order No.	Price Each
600V-S	High Volume Safety Tip	15257	

Needle Blow Gun Tips



These Needle Tips allow the user to get into and blow out tight cavities, crevices and dies that are too narrow for other tips to reach. The needle portion is made from stainless steel and the nickel plated brass base with 1/8" MPT will fit most blow guns.

Model No.	Description	Order No.	Price Each
SNT-1	.042" x 15/16"	22361	
SNT-2	.050" x 1-3/16"	22362	
SNT-3	.072" x 1-3/4"	22363	
SNT-4	.095" x 2-15/32"	22364	
SNT-5	.134" x 2-3/4"	22365	
SNT-KIT-DPB	Blow Gun Needle Tip Assortment	9922246	

Extended Nozzle Safety Pistol Grip Blow Gun



Slender 4" nozzle allows access to hard to reach places and holes as small as .200".

Model No.	Description	Order No.	Price Each
770S	Safety Tip	92271	

Pistol Grip Safety Tip Blow Gun



Assures user comfort even during long term use.

Model No.	Description	Order No.	Price Each
700S	Safety Tip	13473	

Rubber Tip Blow Gun



Ideal for blowing out molds or any other delicate surface brass tips might damage.

Model No.	Description	Order No.	Price Each
601	Rubber Tip	13158	

BLOW GUN KIT

SERIES 959:

Blow Gun Kit includes a tip for virtually every application

- 771 Pistol-Grip Blow Gun-light weight yet rugged with variable flow control
- Non-Safety tip for applications that require a concentrated air stream (SAT15)
- Standard Safety tip for OSHA compliance (ST10)
- Safety Booster tip for OSHA compliance and higher volume (ST11)
- High Volume Safety Tip for OSHA compliance, low air consumption and highest volume (SV-10)
- Inflator tip fits over valves to inflate tires
- Rubber tip for blowing out molds or use with other delicate surfaces (SAT13)



- Assortment of five needle tips for precise air delivery (SNT-Kit)
- 10" Safety Extension Tip OSHA compliant extension tip (ST210)
- A connector so the blow gun is ready to use right out of the box



- Strong transparent cover allows customers to see kit contents
- Durable and compact for easy storage in a work area or toolbox
- Gun features a brass-reinforced 1/4" FPT inlet
- Contents lock into place within the kit to ensure that they remain stationary and undamaged when not in use

Model No. BG-KITCST

Order No. 9590010	Price: <input type="text"/>
-------------------	-----------------------------



COUPLERS AND CONNECTORS



SERIES 959:

Industrial Interchange Couplers (15 Series)

1/4" Body Size



Thread/Barb	Female Model No.	Order No.	Price Each	Male Model No.	Order No.	Price Each
1/4"	150	11552		152	11573	
3/8"	151	11566		155	11601	

Industrial Interchange Connectors (15 Series)

1/4" Body Size



Thread/Barb	Female Model No.	Order No.	Price Each	Male Model No.	Order No.	Price Each
1/4"	1502	9911650		1501	11636	
3/8"	1505	11671		1503	11657	

Industrial Interchange Couplers (58 Series)

3/8" Body Size



Thread/Barb	Female Model No.	Order No.	Price Each	Male Model No.	Order No.	Price Each
1/4"	582	9912252		583	9912259	
3/8"	580	912238		581	9912245	

Industrial Interchange Connectors (58 Series)

3/8" Body Size



Thread/Barb	Female Model No.	Order No.	Price Each	Male Model No.	Order No.	Price Each
1/4"	5804	9912322		5803	12315	
3/8"	5802	9912308		5801	9912301	

ARO Interchange Couplers (14 Series)

1/4" Body Size



Thread/Barb	Female Model No.	Order No.	Price Each	Male Model No.	Order No.	Price Each
1/4"	140	9911461		142	11489	
3/8"	141	9911482		145	11499	

ARO Interchange Connectors (14 Series)

1/4" Body Size



Thread/Barb	Female Model No.	Order No.	Price Each	Male Model No.	Order No.	Price Each
1/4"	1402	11510		1401	11503	
3/8"	1405	11531		1403	11517	

Tru-Flate Interchange Couplers (16 Series)

1/4" Body Size



Thread/Barb	Female Model No.	Order No.	Price Each	Male Model No.	Order No.	Price Each
1/4"	160	11726		162	11747	
3/8"	161	11740		165	11768	

Tru-Flate Interchange Connectors (16 Series)

1/4" Body Size

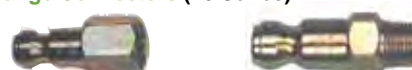

Thread/Barb	Female Model No.	Order No.	Price Each	Male Model No.	Order No.	Price Each
1/4"	1602	11803		1601	11796	
3/8"	1605	11824		1603	11810	

Lincoln Interchange Couplers (17 Series)

1/4" Body Size



Thread/Barb	Female Model No.	Order No.	Price Each	Male Model No.	Order No.	Price Each
1/4"	170	11886		172	11893	

Lincoln Interchange Connectors (17 Series)

1/4" Body Size



Thread/Barb	Female Model No.	Order No.	Price Each	Male Model No.	Order No.	Price Each
1/4"	1702	11907		1701	9911900	

Megaflow Interchange Couplers (11 Series)

1/4" Body Size



Thread/Barb	Female Model No.	Order No.	Price Each	Male Model No.	Order No.	Price Each
1/4"	110	911103		112	11117	
3/8"	111	11110		-		

Megaflow Interchange Connectors (11 Series)

1/4" Body Size



Thread/Barb	Female Model No.	Order No.	Price Each	Male Model No.	Order No.	Price Each
1/4"	1102	11145		1101	9911138	
3/8"	1105	911159		1103	9991152	

Automatic Universal Connectors

1/4" Body Size

Body Size	Thread/Barb	Female Model No.	Order No.	Price Each
1/4"	1/4"	150U	11560	



Automatic Universal Connectors

1/4" Body Size

Body Size	Thread/Barb	Male Model No.	Order No.	Price Each
1/4"	1/4"	152U	11578	





FOR APPLICATIONS WHERE SPACE IS LIMITED SUCH AS COMPACT CONTROLS AND MINIATURE CIRCUITS

Miniature Series Filters

Manual drain allows quick and easy removal of fluids. Bowl volume 1.5 oz.



Model No.	Pipe Size	Order No.	Price Each
MF1	1/8"	18499	
MF2	1/4"	18492	

Miniature Series Lubricators

Tamperproof cap can be used to adjust oil delivery rate and lock desired lubrication level in place.

Provides constant oil delivery at both steady and pulsing air flows.



Model No.	Pipe Size	Order No.	Price Each
ML1	1/8"	18513	
ML2	1/4"	18506	

Miniature Series Regulators

Built in self-relieving feature prevents excessive downstream pressure build up.



Model No.	Pipe Size	Order No.	Price Each
MR1	1/8"	18527	
MR2	1/4"	18520	

Miniature Series Filters, Regulator, and Lubricator Assemblies

Features tough die cast zinc body construction with either 1/8" or 1/4" in/out port.

Includes a 0 - 160 psi pressure gauge.



Model No.	Pipe Size	Order No.	Price Each
MFRL1-G	1/8"	77295	
MFRL2-G	1/4"	77367	

TOP LEVEL PERFORMANCE AND LONG LASTING DURABILITY

Heavy Duty Series Filters

Manual drain, polycarbonate bowl, and 40 micron sintered bronze element supplied as standard.



Model No.	Pipe Size	Order No.	Price Each
8822	1/4"	15491	
8823	3/8"	9915659	
8824	1/2"	9915876	

Heavy Duty Series Lubricators

Polycarbonate bowl supplied as standard.

Can be filled without shutting down air lines feeding production equipment.



Model No.	Pipe Size	Order No.	Price Each
8842	1/4"	16525	
8843	3/8"	16546	
8844	1/2"	16581	

Heavy Duty Series Regulators

Assures highest flow rates with accurate control and fast response.

Pressure gauge 0-125 psi supplied as standard.



Model No.	Pipe Size	Order No.	Price Each
8802G	1/4"	15172	
8803G	3/8"	15235	
8804G	1/2"	15298	

Heavy Duty Filter, Regulator, and Lubricator Assemblies

Top level performance and long lasting durability are assured with features such as extra large filter elements, critically close air regulation, positive mist type atomization & die cast aluminum bodies.



Model No.	Pipe Size	Order No.	Price Each
8882AAG	1/4"	16922	
8883AAG	3/8"	16964	
8884AAG	1/2"	17006	

While we show only the most popular  items we can supply their entire range of products; please inquire.



AEROSOLS CANNOT BE SHIPPED BY AIR



SERIES 447:

LIQUID THREADLOCKERS

262 Threadlocker
 Medium to High Strength
 A permanent locking threadlocker for fasteners up to 3/4" (20mm) diameter. High lubrication for easy assembly. Excellent for preventing rust and corrosion in extreme chemical/environmental conditions.



Container Size	Order No.	Price
10 ml. Tube	26221	
50 ml. Bottle	26231	
250 ml. Bottle	26241	

242[®] Threadlocker
 Medium Strength
 A general-purpose, removable threadlocker for fasteners between 1/4" and 3/4" (6 to 20 mm) diameters. Controlled lubricity for accurate clamp loads. Parts can be separated using hand tools.



Container Size	Order No.	Price
10 ml. Bottle	24221	
50 ml. Bottle	24231	
250 ml. Bottle	24241	

222 MS Threadlocker
 Low Strength/Small Screw
 Ideal for fastener diameters of 1/4" (6mm) and smaller. Controlled lubricity for accurate clamp loads. Parts can be separated using hand tools.



Container Size	Order No.	Price
10 ml. Bottle	22221	
50 ml. Bottle	22231	
250 ml. Bottle	22241	

SURFACE PREPARATION

7649 Primer N
 A solvent-based primer that features very long on-part life. Decreases the set-up time of Loctite[®] Threadlockers and increases breakaway torque on most fastener surfaces. Ideal for cure conditions below room temperature.

Container Size	Order No.	Price
25 gm. Aerosol Can	21347	
1.75 fl oz. Bottle	19269	
4.5 oz. Aerosol Can	21348	



THREAD SEALANT

565 PST[®] THREAD SEALANT
 Controlled Strength
 A general-purpose instant sealant for tapered and straight/tapered fittings. Controlled strength for ease of disassembly.



50 ml. Tube
 Order No. 56531
 Price:

BONDING ADHESIVES

454 PRISM[®] Surface Insensitive Instant Adhesive Gel
 A General-purpose, no-run clear gel. Can be applied to vertical surfaces. Excellent for almost all surfaces. Ideal for porous substrates and rough and acidic surfaces.



495 SUPER BONDER[®] Instant Adhesive
 A general-purpose adhesive designed to bond rubber, metal and plastic parts with gaps to .004".

Product No.	Order No.	Container Size	Price
454	9945404	3 gm Tube	
454	45440	20 gm Tube	
495	49504	3 gm Tube	
495	49550	1 oz Bottle	

COATING

Color Guard[®] Tough Rubber Coating
 Inhibits rust and corrosion; seals, insulates and identifies almost any material in minutes. Creates a non-slip gripping surface. Rubber coating won't crack or chip. Acid and alkali resistant. Lasts for years. Use to 200°F. Dip, spray or brush to apply. Suggested applications include: Tools, metal, electrical connections, masonry, wood, conveyors, glass, rope, fabric.



Size	Black	Blue	Red	Yellow	Price
14.5 oz. Can	34979	34982	34985	34988	

While we show only the popular **LOCTITE** items we can supply their entire range of products; please inquire.

MACHINE SHOP DISCOUNT SUPPLY

SPECIALTY FLUIDS



AEROSOLS CANNOT BE SHIPPED BY AIR



SERIES 447:

LUBRICANTS



C5-A Copper Based Anti-Seize
Exclusive formula suspends copper and graphite in a high-quality grease. Protects metal parts from rust, corrosion, galling and seizing at temperatures to 1800°F (982°C). Tested to MIL-A-907.

Container Size	Order No.	Price
8 oz. Brush Top	51147	
1 lb. Brush Top	9951007	



Heavy Duty Anti-Seize
Metal-Free. Excellent lubricity. Provides outstanding lubrication to all metals including stainless steel, aluminum, and soft metals up to 2400° F (1315°C).

Container Size	Order No.	Price
9 oz. Brush Top	9951605	
1 lb. Brush Top	9951606	



Nickel Anti-Seize
Copper-free. Recommended for stainless steel and other metal fittings. For preventing corrosion, seizing and galling in harsh, chemical environments, and temperatures to 2400° F (1315°C).

Container Size	Order No.	Price
8 oz. Brush Top	77124	
1 lb. Brush Top	77164	



Silver Grade Anti-Seize
Heavy duty, temperature-resistant, petroleum-based lubricant compound fortified with graphite and metallic flake. Inert, will not evaporate or harden in extreme cold or heat. For use in assemblies up to 1600°F (871°C).

Container Size	Order No.	Price
8 oz. Brush Top	76732	
1 lb. Brush Top	76764	



Graphite-50 Anti-Seize
Electrically conductive, non-metallic. Temperature resistant up to 900°F (482°C). Highly electrically conductive in metal-to-metal joints.

1 lb. Can	Order No. 9951084	Price:
-----------	-------------------	--------



While we show only the popular **LOCTITE** items we can supply their entire range of products; please inquire.

RETAINING COMPOUNDS

609 Retaining Compound
General-purpose low viscosity retaining compound that bonds rigid metal assemblies. Ideal for gap distances up to 0.005" diameter. Fixtures in 10 minutes and provides a shear strength of 3,000 psi after 24 hours. Easily joins dissimilar metals. Withstands temperatures to 300°F.

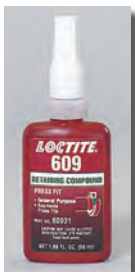

Container Size	Order No.	Price
0.5 ml Capsule	60905	
10 ml. Bottle	60921	
50 ml. Bottle	60931	
250 ml. Bottle	60941	

680 Retaining Compound
High Strength/High Viscosity. A retaining compound for joining fitted cylindrical parts. Fixtures in 10 minutes and provides a shear strength of 4,000 psi on steel after 24 hours. Fills diametral gap distances up to 0.015".



Container Size	Order No.	Price
10 ml. Bottle	68015	
50 ml. Bottle	68035	
250 ml. Bottle	68060	

CLEANER

Electrical Contact Cleaner
Removes grease, oil and other contaminants from electrical parts to prevent contact failure. Dries residue-free in seconds. Non-conductive, non-corrosive, non-flammable. Contains no CFCs or Class I ODCs. Contains HCFC-141 b. May attack some sensitive plastics.



15 oz. Aerosol	Order No. 24379	Price:
----------------	-----------------	--------



SPECIALTY CUTTING AND TAPPING FLUIDS

SERIES 460:



ALL 55 GALLON DRUMS SHIPPED F.O.B. FACTORY

TAPFREE EXCEL CUTTING AND TAPPING FLUID

Tapfree Excel is a high performance cutting oil that is safe for use on all metals. Formulated with a unique blend of low odor extreme pressure additives, Tapfree Excel is pleasant to work with and produces exceptional results especially on hard to cut metals such as stainless steel, titanium and exotic alloys.

- High performance cutting oil formulated to produce tighter tolerances, longer tool life and a better surface finish on all metals.
- Especially effective on difficult to machine metals such as stainless steel, titanium and exotic alloys.
- Clings to the cutting tool for better hold on horizontal operations and less product usage.
- Low odor extreme pressure additives make Tapfree Excel pleasant to work with.



Size	Units per case	Order No.	Price
4 oz. Bottle (.118L)	24	4600005	
8 oz. Bottle (.236L)	12	4630308	
16 oz. Bottle (.473L)	12	4630316	
Gallon Jug (3.78L)	4	4630328	
5 Gallons (18.9L)	1 Pail	4630305	
30 Gallons (114L)	1 Drum	4630330	
55 Gallons (208L)	1 Drum	4630355	

TAPFREE 2 CUTTING AND TAPPING FLUID

Tapfree 2's Environmentally Safe HYDRO-LUBE formulation offers remarkable performance in a water based cutting fluid. Easy, precise cutting and quick cleanup make Tapfree 2 the preferred choice for production jobs, maintenance repairs and use on construction sites. Especially effective on low and medium carbon steel, cast iron, milder grades of stainless steel and alloy steels.

- Proprietary Hydro-Lube formulation delivers amazingly efficient cutting action, reduces heat buildup, and extends tool life.
- Produces a superior finish and tight tolerances on most production metals from aluminum to stainless steel; not for use with magnesium.
- Easy to clean up - light residue is wiped away with a damp rag.
- Environmentally Safe formula better for workers and the environment.



Size	Units per case	Order No.	Price
4 oz. Bottle (.118L)	24	4600008	
8 oz. Bottle (.236L)	12	4620208	
16 oz. Bottle (.473L)	12	4620216	
Gallon Jug (3.78L)	4	4620228	
5 Gallons (18.9L)	1 Pail	4620205	
30 Gallons (114L)	1 Drum	4620230	
55 Gallons (208L)	1 Drum	4620255	

NEW ALUMTAP CUTTING AND TAPPING FLUID

New Alumtap is a special compound that enables speedy and precise machining of aluminum. It has exceptional penetrating and lubricating qualities that reduce galling and extend tool life while improving fit and finish. It is the best cutting fluid available for use on aluminum, magnesium, copper, and other soft metals.

- Specifically formulated for the machining characteristics of aluminum and other soft metals.
- Produces an ultrafine surface finish that is clean and bright without metal smear or staining.
- Increases tool life by inhibiting spot welding and reducing the tendency of aluminum to adhere to the cutting edge of the tool.
- The answer to "problem" aluminum jobs that require tight tolerance.



Size	Units per case	Order No.	Price
4 oz. Bottle (.118L)	24	4600006	
16 oz. Bottle (.473L)	12	4660616	
Gallon Jug (3.78L)	4	4660628	
5 Gallons (18.9L)	1 Pail	4660605	
30 Gallons (114L)	1 Drum	4660630	
55 Gallons (208L)	1 Drum	4660655	

CLEANTAP CUTTING AND TAPPING FLUID

Cleantap is a synthetic, aqueous based cutting fluid developed for use on operations where the presence of certain chemicals cannot be tolerated. It improves cutting performance without the use of chlorine, sulphur, silicone or oil. Recommended for plastics and all jobs where corrosion is of prime concern.

- Contains a non-corrosive extreme pressure additive that helps keep tools sharp and improves surface finish.
- Does not contain oil, chlorine, sulfur or silicone.
- Will not corrode or stain any ferrous or nonferrous metal and will not craze plastics.
- Easy to clean up - light residue is wiped away with a damp rag.



Size	Units per case	Order No.	Price
4 oz. bottle (.118L)	24	4600007	
16 oz. Bottle (.473L)	12	4650516	
Gallon Jug (3.78L)	4	4650528	
5 Gallons (18.9L)	1 Pail	4650505	
30 Gallons (114L)	1 Drum	4650530	
55 Gallons (208L)	1 Drum	4650555	



TAPPING & CUTTING FLUIDS, ETC.

SERIES 689:



ALL 55 GALLON DRUMS SHIPPED F.O.B. FACTORY

TAPMATIC TRICUT®

Clear plastic bottles allow end users to quickly check volume levels.

- Available in liquid or paste
- Suitable for most metals; excellent for stainless steel
- Extends tool life
- Reduces production costs
- Improves surface finish
- Allows increased removal rates
- Reduces friction
- Flows directly to cutting edge
- Suitable for high and low speed applications
- Provides smooth, accurate cutting action
- Is non-corrosive to steel



Size	Order No.	Price
16 fl. oz. liquid (0.473 liter)	6005316	
1 gal. liquid (3.78 liters)	6005328	

TAPMATIC NATURAL

Meets USDA requirements for P1.

- Nontoxic, nonhazardous and biodegradable
- Does not irritate the skin, eyes or respiratory tract
- Does not contain 1,1,1 trichloroethane, sulfur, chlorine, chlorinated solvents, water, mineral oil or inactive fillers
- High performance lubricating ability eliminates galling and seizing
- Safe on all metals



Size	Order No.	Price
16 fl. oz. (0.473 liters)	6044220	
1 gal. (3.78 liters)	6044230	
5 gal. (18.93 liters)	6044240	
55 gal. (208 liters)	6044260	

TAPMATIC EDGE LIQUID

Meets USDA requirements for P1.

Edge liquid replaces flood coolants and eliminates disposal costs.

- Compatible with drop applicators
- High film strength
- Reduces friction
- Compatible with oil and water systems
- Replaces flood coolants and eliminates disposal costs
- Low toxicity
- Increases tool life
- Safe on all metals
- Excellent for high alloy metals



Size	Order No.	Price
16 fl. oz. (0.473 liters)	8943020	
1 gal. (3.78 liters)	8943030	

TAPMATIC #1 GOLD

Meets USDA requirements for P1.

- Great for hard to machine metals
- Excellent for low speed, high pressure applications
- Minimizes torque increases
- Does not contain 1,1,1 trichloroethane, chlorinated paraffins, water, solvents or inactive fillers
- Aerosol provides a pinpoint stream with foaming action
- Safe on all metals



Meets or exceeds these specs:

Boeing BAC 5008

Boeing D6-48809

Size	Order No.	Price
16 fl. oz. (0.473 liters)	6040320	
11 oz. (312 g.) aerosol	6040312	
1 gal. (3.78 liters)	6040330	
5 gal. (18.93 liters)	6040340	
55 gal. (208 liters)	6040360	

TAPMATIC AQUACUT

Meets USDA requirements for P1.

- Water-based formula
- Excellent for high speed, low pressure applications
- Nonflammable
- Nonhazardous
- Does not contain 1,1,1 trichloroethane, sulfur, chlorine or oils
- Safe on all metals, except magnesium
- Corrosion inhibitors prevent flash rusting
- Provides fine finishes. Cinnamon scent



Size	Order No.	Price
16 fl. oz. (0.473 liters)	6001216	
1 gal. (3.78 liters)	6001228	
5 gal. (18.93 liters)	6001205	

TAPMATIC EDGE LUBE AND CREME

Meets USDA requirements for P1.

Edge Lube:

- Excellent for belt, wheel and disc grinding or sawing applications.
- White, solid waxy bar

Edge Creme:

- Excellent for vertical applications
- For use when drilling, tapping blind holes, forming, bending, pre-coating fasteners and lubricating rubber seals.
- Squeeze tube allows easy usage

Both:

- Biodegradable
- Eliminates heat buildup and belt loading
- Does not contain any hazardous chemicals
- Compatible with oil and water systems
- Extends grinding wheel life
- Low toxicity
- Safe on all metals



Description	Size	Order No.	Price
Edge Lube	13 oz. (364 grams)	8943200	
Edge Creme	11 oz. (.325 liters)	8943100	



CUTTING AND GRINDING FLUIDS AND OILS

SERIES 691:

ALL 55 GALLON DRUMS SHIPPED F.O.B. FACTORY



While we show only the popular **RUSTLICK** items we can supply their entire range of products; please inquire.

ULTRACUT 250R & 255R

CHARACTERISTICS

Safe, Biostable, Water Soluble Oils

- 250R - Contains Non-Chlorinated EP additives only
- 255R - Contains Chlorinated and Non-Chlorinated EP additives
- Provides long sump life
- Low foaming

APPLICATIONS

250R - General purpose, medium duty applications

255R - High Performance/severe applications including hard to machine alloys

- Can be used on all metals



Description	250R		255R	
	Order No.	Price	Order No.	Price
1 Gal (4/case)	9174615		-	
5 Gal	9174605		9174705	
55 Gal	9174655		9174755	

WS-5050

CHARACTERISTICS

Heavy duty soluble oil

- Effective chlorinated E.P. additive provides excellent tool life
- Special additives protect neoprene seals

APPLICATIONS

General purpose, medium/severe duty applications

- Can be used on all ferrous metals
- Not recommended for Titanium
- Compatible with CNC machining



Description	Order No.	Price
1 Gal (4/case)	9174016	
5 Gal	9174056	
55 Gal	9174556	

WS-500A

CHARACTERISTICS

Chlorine free soluble oil

- Designed with a proprietary E.P. additive
- Does not contain chlorine or active sulfur, thereby reducing disposal cost

APPLICATIONS

Excellent for general machining

- Good for Titanium, Inconel X, Aluminum, Rene 41, Stainless Steel and other metals
- Compatible with CNC machining



Description	Order No.	Price
5 Gal	9174055	
55 Gal	9174555	

WS-11

CHARACTERISTICS

Non-Chlorinated soluble oil

- An economical soluble oil

APPLICATIONS

General purpose, medium-duty applications

- Can be used as a light film rust preventative



Description	Order No.	Price
1 Gal	9174013	
5 Gal	9174053	
55 Gal	9174553	

SS-405L

CHARACTERISTICS

Semi-synthetic coolant

- Provides excellent lubricity and protects machines & parts from rust

APPLICATIONS

General purpose, for machining and grinding

- Can be used on many different metals including Aluminum



Description	Order No.	Price
5 Gal	9178405	
55 Gal	9178410	

VYTRON-N

CHARACTERISTICS

Synthetic coolant

- High level of rust prevention
- Long sump life prevents rancidity

APPLICATIONS

General purpose, machining and grinding on ferrous metals

- Setting the standard for over 20 years



Description	Order No.	Price
1 Gal (4/ case)	9175014	
5 Gal	9175054	
55 Gal	9175554	

G-25-J

CHARACTERISTICS

Grinding Synthetic coolant

- High level of rust prevention, non-foaming, transparent
- Enables the rapid settling of residues, which eliminates wheel buildup and ensures finer finishes

APPLICATIONS

General purpose, designed for grinding applications

- Excellent for Blanchard grinding



Description	Order No.	Price
1 Gal (4/case)	9175012	
5 Gal	9175052	
55 Gal	9175552	

CARBIDE POWERGRIND

CHARACTERISTICS

Synthetic carbide grinding fluid

- Cobalt leaching is minimal providing worker health and safety
- Its excellent lubricity and flushing keep grinding wheels clean
- High level of rust prevention

APPLICATIONS

High Performance Carbide Grinding Coolant

- Formulated to minimize the leaching of cobalt from carbide and to prevent chemical damage to carbide in grinding applications
- Can be used with all metals except magnesium



Description	Order No.	Price
5 Gal	9174052	
55 Gal	9174552	



EDM OILS: CLEANERS AND COOLANT MANAGEMENT



SERIES 691:

ALL 55 GALLON DRUMS SHIPPED F.O.B. FACTORY

EDM-250

CHARACTERISTICS - Dielectric Oil

- Low viscosity for excellent flushing and finishing
- Virtually odorless

APPLICATIONS

EDM machining, good for all filters

- Resists thermal degradation from high-amperage applications up to 400 amps

Description	Order No.	Price
55 Gal	9172550	



EDM-30

CHARACTERISTICS - Dielectric Oil

- Low viscosity allows for fast settling that yields higher quality finishes

APPLICATIONS

EDM machining

- Designed for paper cartridge filtration up to 150 amps

Description	Order No.	Price
5 Gal	9172052	
55 Gal	9172552	



KLEENZOL DY

CHARACTERISTICS - Water Soluble Alkaline Cleaner

- Non-flammable, non-toxic and biodegradable

APPLICATIONS

- Sump cleaner that quickly penetrates and dislodges grimy buildups of chips and oil residues

Description	Order No.	Price
1 Gal(4/case)	9176012	
5 Gal	9176052	
55 Gal	9176552	



GROTAN

CHARACTERISTICS - Broad Spectrum Bactericide

APPLICATIONS

- Provides added protection to extend coolant life.
- For use in individual sumps and large central systems.
- Helps protect machines, tools and workpieces from corrosion.
- Controls bacteria and fungus growth

1 Gal (4/case)

Order No.	Price
9177011	



TRAMP OIL SKIMMER

Tramp oils seal the surface of the coolant in your sump against air, providing an ideal growth environment for the microorganisms, which cause a host of problems. The tramp oil skimmer removes these oils at a rate of up to 1-1/2 gallons per hour automatically, reliably and economically.

Description	Order No.	Price
12" Skimmer	9178012	
18" Skimmer	9178018	



CNC SKIMMER - SC3000

Coalescent Skimmer

This portable coolant skimmer removes up to 95% of floating tramp oils from machine tool sumps. Detachable floating oil skimmers have no positioning requirements, provide perfect fluid flow and are easily installed. With the SC3000, the entire coolant filtration process takes place quickly, without removing the machine from operation

- Portable design for easy relocation and all multiple machine use
- Prevention of rancidity and "Monday morning odor"
- One-time setup with equipment modification required
- Reduced coolant replacement and disposal costs



Description	Order No.	Price
SC3000 Coalescent Skimmer	9178100	
SC3000 Float (pair)	9178101	
SC3000 Filter cartridge	9178102	



SafeTap

TAPPING FLUIDS

SERIES 691:

Aerosols cannot be shipped by air.



SafeTap

SAFE TAP PLUS

SafeTap Plus is a unique blend of synthetic additive creating a water based tapping fluid. The purpose of SafeTap Plus is to improve tool life and give better threads in tapped holes while providing the worker with a safe and clean environment.

- Higher viscosity and lubricity
- High in rust protection
- No oily residue
- No mineral oils or solvents
- Water-based formula for easy clean-up
- Safe for all metals except magnesium



Description	Order No.	Price
4 oz. (24/case)	9171911	
16 oz. (12/case)	9171912	
1 Gal. (4/case)	9171913	
5 Gal.	9171914	

SAFE TAP ULTIMA

SafeTap Ultima is an ultra-clean, high performance, environmentally compatible tapping fluid.

- 100% biodegradable
- Water-Clear
- All natural ingredients
- Non-staining and odorless
- Safe for all metals

Description	Order No.	Price
16 oz. (12/case)	9171952	
1 Gal. (4/case)	9171953	
5 Gal.	9171954	







SPECIALTY FLUIDS



SPECIALTY AEROSOLS
SERIES 693:



AEROSOLS CANNOT BE SHIPPED BY AIR

Product	Description	Performance	Applications	Order No. Price	
CORROSION PREVENTATIVES -REMOVABLE PROTECTIVE COATINGS					
Tool & Die Saver 11 oz.	Greasy elastic film	Absorbs moisture, fortified with lanolin Neutralizes acid formed by corrosive atmosphere.	Good for chucks, set-up jigs, tools, and stored molds. Ideal for long-term and long-distance storage. Easy to remove.	6933090	
Rust Inhibitor 11 oz.	Greasy elastic film	Absorbs moisture, fortified with lanolin. Neutralizes acid formed by corrosive atmosphere.	Prevents rust on tools, steel stock, parts and temporary or extended protection of machinery. Good for indoor storage.	6936007	
LUBRICANTS AND COOLANT					
Cutting Oil 10.5 oz.	Light oil	All purpose lubricant and coolant.	Turret lathes, gear cutters, grinders, automatic screw machines, and pipe threaders.	6937020	
TOOL ROOM SUPPLIES					
Blue Tool-maker's Ink 12 oz.		Enables accurate scribing without glare. Produces a quick drying film that will not chip. May be scribed within 5 minutes of application.	For production layouts, patternmaking, tool, die, and modelmaking. May be used for templates and machined parts.	6946001	
Toolmaker's Ink Remover 10.5 oz.	Solvent spray for layout fluids	Removes ink without residue	Fast acting and quick removal of toolmaker's ink and layout fluids from the surface of completed work. Can also be used as a paint stripper.	6946095	
MISCELLANEOUS					
Drive Belt Dressing 12 oz.	Clear liquid	Increases gripping and pulling power. Stops slippage of all types of belts while stopping squeaks and squeals. Helps preserve leather and rubber.	For use on compressors, pumps, conveyors, generators, fans, textile, automotive and farm equipment.	6938079	
Tan Box Saver 12 oz.		A cost effective spray that dries quickly, surfaces appear new, won't rub off.	For use on cartons or to salvage carton overruns. Covers up old print, or light stains. Boxes can then be restenciled or relabeled.	6932811	

SPECIALTY FLUIDS

MILWAUKEE SURE SHOT
SERIES 639:

- 1 Qt. capacity
- All metal construction
- Rechargeable with compressed air
- Working Pressure 80-150 PSI
- Adjustable spray nozzle
- Great for degreasers, cleaners, solvents, rust inhibitors, etc.
- Not recommended for paints



ENVIRONMENTALLY SAFE • SAVE THE OZONE

- Refillable, Rechargeable
- Completely Portable
- Use Inexpensive Bulk Liquids, Eliminate Aerosol Disposal Problems
- Non Ozone-Depleting



Anything an aerosol sprays SURE SHOT sprays safer !
Just fill with liquid, pressurize with standard air chuck and spray

Order No. 600059 | **Price**

TOOL AND INSTRUMENT OIL SERIES 789:



- 4 fl.oz. (0.1 liter) Plastic Bottle
- Assures maximum protection and lubrication of working parts.
- Especially useful for lubricating and protecting fine instruments, micrometers and other tools, light machinery and countless other applications.
- High-refining makes oil colorless.

Catalog No.	EDP No.	Price
1620	53216	

GORRILLA BRAND PREMIUM GLUE™ SERIES 526:



100% Solvent Free • Polyurethane
Absolutely the finest, strongest and most pure adhesive in the world.

- Bonds Metal, Ceramics, Wood, Stone, Plastics and more.
- Time tested polyurethane with 25 years of proven usage.
- Uses no thickeners, solvents or fillers
- Can be used indoors and out. (Only true waterproof glue)
- Sandable and stainable.
- Greater usable temperature range (40 to 130 degrees)
- 3 to 4 times the coverage of other glues.
- Virtually odorless.



4 oz. Bottle	Order No. 6050004	Price	
8 oz. Bottle	Order No. 6050008	Price	



M1 ALL PURPOSE LUBRICANT SERIES 792:



A special formula originally developed by Starrett to protect high quality precision tools. M1 when applied produces a micro-thin air-tight coating film that simultaneously dries as it protects, avoiding dirt, grime, etc. that other "wet" lubricants actually attract.
SPRAYS UPSIDE DOWN: The can will spray upside down in awkward places without losing propellant power.

LUBRICATES: M1 is free of silicone, making it an excellent lubricant that is also easily removed to prep surfaces for paint. Its ability to stand up to extreme temperatures makes it ideal year-round.

PENETRATES: Deep-down penetration works quickly to free frozen nuts, bolts and metal parts. Actually gets under caked-on dirt to the clean metal.

PREVENTS RUST: Protects metal against rust and corrosion damage for months by providing a molecular shield that locks to the metal.

CLEANS: Actually removes grease, tar and grime from metal parts and painted surfaces. Cleans and polishes for lasting protection.

STOP SQUEAKS: Has instant lubrication properties that spread into hard to - reach metal parts to stop squeaking and sticking.

DISPLACES MOISTURE: M1 is not soluble in water, so it gets under moisture to lift it away from the surface to be protected.

NON- CONDUCTIVE: Prevents short circuits in high moisture environments. Halts electrical leakage from wet ignition wires.

ENVIROMENTALLY FRIENDLY: Contains no harmful fluorocarbons/detergents and is also FDA approved for using in or near food-related environments.

Description	Catalog No.	EDP No.	Price
12 oz aerosol can	M1-95173	95173	
1 gallon container	M-1.01	93221	
5 gallon pail	M-1.05	93227	
53 gallon drum	M-1.53	93233*	
1 pint bulk spray dispenser, empty	M-1.15	93251	

*F.O.B. Factory

SIMPLE GREEN® SERIES 249:

Cleaner / Degreaser

Biodegradable, non-flammable, non-abrasive, non-toxic concentrate that can be custom-diluted to economically tackle any cleaning job. Safer alternative to hazardous chemicals and solvents. Exempt from OSHA and EPA special handling and personnel protection requirements for hazardous chemicals. Meets Federal Clean Air Act.

Simple Green-All Purpose Cleaner/Degreaser has a pleasant sassafras scent. Contains no petroleum distillates. Authorized by USDA for use in federally inspected meat and poultry plants.

Crystal Simple Green-Industrial Strength Cleaner/Degreaser for critical cleaning applications that demand a clear and fragrance-free solution. Ideal for industrial /manufacturing, electronics and parts washers. Meet FDA requirements for cleaning in cosmetic, medical and pharmaceutical environments.



55 gal. drums shipped F.O.B. factory.



Size	Case Qty.	Order No.	Price
Simple Green-All Purpose Cleaner/Degreaser			
24oz. Spray Bottle	12	4113012	
1 gal. Bottle	6	4113005	
5 gal. Pail	1	4113006	
55 gal. Drum	1	4113008	
Crystal Simple Green-Industrial Strength Cleaner/Degreaser			
24oz. Spray Bottle	12	4119024	
1 gal. Bottle	6	4119128	
5 gal. Pail	1	4119005	
55 gal. Drum	1	4119055	



PNEUMATIC TOOLS

SERIES 321:



While we show only the popular **MSI PRO** items we can supply their entire range of products; please inquire.

DIE GRINDERS

Features:

- Tool will accommodate both 1/8" (3mm) (with adapter or collet) and 1/4" (6mm) accessories.
- Variable speed throttle for positive speed control.
- Built in adjustable air regulator allows for a wide range of applications.
- Kit includes: Die grinder, 10 mounted points, 1/8" collet, and wrenches in plastic case.



9010025 1/4" Die Grinder



9918008 1/4" Die Grinder Kit

Order No.	Speed	Air Cons. (CFM)	Length	Weight	Price
9010025	22,000	4	6-3/4"	1-1/8 lbs.	
9918008	22,000	4	6-3/4"	1-1/8 lbs.	

1/8" (3mm) Adapter

Order No. 5080522	Price	
-------------------	-------	--

1/8" (3mm) Collet

Order No. 5080500	Price	
-------------------	-------	--

DIE & ANGLE GRINDERS

Features:

- Safety handle for accident prevention.
- Angle head designed to fit tight areas.
- 10012 has a built in governor that shuts tool down in case of overspeed.



9910007 1/4" Angle Die Grinder



9910012 4" Angle Grinder

Order No.	Wheel Size	Spindle Size	Speed	Air Cons. (CFM)	Length	Weight	Price
9910007	-	1/4" Collet	22,000	4	6-1/2"	1 lbs.	
9010012	4"	3/8" x 24	11,000	10	9"	4 lbs.	

ANGLE GRINDERS

Features:

- Heavy duty construction for tough grinding jobs.
- 5" tool accepts both 4-1/2" and 5" grinding wheels.
- Dead handle and rear throttle control for balanced tool operation



10019 5" Angle Grinder



10013 7" Angle Grinder

Order No.	Speed	Wheel Size	Spindle Thread	Air Cons. (CFM)	Length	Weight	Price
10019	10,000	4-1/2" to 5"	5/8" x 11	11	10-1/4"	4-1/2 lbs.	
10013	7,000	7"	5/8" x 11	12.5	13-1/2"	6-1/2 lbs.	

SANDERS

Features:

- Balanced construction for vibration free performance.
- Front exhaust helps keep work surface clear.



16013 6" Dual Action Sander

Features:

- 360° swing arm for all around positioning comfort.
- Rear exhaust directs air away from work surface.



9916026 3/4" x 20 -1/2" Mini Belt Sander

Order No.	Speed	Pad/Belt Size	Air Cons. (CFM)	Length	Weight	Price
16013	10,000	6"	12	8-3/4"	4 lbs.	
9916026	16,000	3/4" x 20-1/2"	14.2	13-3/4"	3.1 lbs.	



CLUTCH SCREWDRIVERS

Features:

- Reversible action for assembly and disassembly.
- Quick change hex collet.
- Excellent power to weight ratio handles tough jobs with minimal fatigue.



14011 1/4" Adjustable Clutch Screwdriver



14013 1/4" Positive Clutch Screwdriver

Order No.	Speed	Torque (in/lbs)	Air Cons. (CFM)	Length	Weight	Price
14013	1,800	115	4	7"	2-1/2	
14011	1,800	45 - 115	4	7"	2-1/2	

REVERSIBLE DRILLS

Features:

- Muffled handle exhaust for quiet operation.
- Variable speed trigger.
- Equipped with Jacobs® chuck.
- One hand forward and reverse lever.



14003 1/2" Reversible Drill



14004 3/8" Reversible Drill

Order No.	Speed	Chuck Size	Air Cons. (CFM)	Length	Weight	Price
14004	1,800	3/8"	4	6-1/2"	3	
14003	500	1/2"	4	7"	4	

RATCHET WRENCH & BUTTERFLY IMPACT WRENCH

Features:

- Teasing throttle for added control.
- Light weight aluminum handle for less operator fatigue.
- Butterfly throttle for single handed forward and reverse operation.
- 360° regulator on 15021.



15003 3/8" Ratchet Wrench



9915021 3/8" Butterfly Impact Wrench

Order No.	Square Drive	Free Speed	Torque (Ft/lbs)	Bolt Capacity	Air Cons. (CFM)	Length	Weight	Price
15003	3/8"	150	45	3/8"	4	10"	2-1/2	
9915021	3/8"	10,000	75	3/8"	3	5-1/2"	2-1/8	

IMPACT WRENCHES

Features:

- Ring socket retainer allows for rapid socket changes.
- Through bolt reverse lever allows for one hand forward and reverse control.
- Adjustable speed regulator sets and maintains air pressure for both forward and reverse operation.



9915022 1/2" Impact Wrench



15016 3/4" Impact Wrench

Order No.	Square Drive	Free Speed	Torque (Ft/lbs)	Bolt Capacity	Air Cons. (CFM)	Length	Weight	Price
9915022	1/2"	7,000	230	5/8"	4.75	7"	5-1/4	
15016	3/4"	4,600	700	1"	10.25	9-3/4"	10-1/2	

100-N/7 Single Speed Rotary Tool Kit

- Ideal when one speed is all you need
- Ideal for shaping, hollowing, grooving, slotting, inlaying and making tapered holes in soft metals, plastics and woods especially on curved surfaces
- Includes 7 genuine Dremel accessories



Tool Features & Benefits

- Single speed control for fulltime 35,000 rpm operation
- Cool-running ball bearing construction for smooth and quiet operation
- Replaceable motor brushes extend tool life
- Lightweight design for comfort during prolonged use

Specifications

- **Amperage** 1.15 • **Cord Length** 6' • **Speed** 35,000rpm
- **Voltage** 120 AC, 50-60 Hz • **Warranty** 2 years • **Weight** (lbs.) 18 oz.

Includes

- Dremel 100 Series Single Speed Rotary Tool • 402 Mandrel • 407 Coarse 1/2" Sanding Drum • 415 Dressing Stone • 420 Heavy Duty Emery Cut-Off Wheel • 432 1/2" 120 Grit Sanding Band • 932 Aluminum Oxide Grinding Stone • 84922 Silicon Carbide Grinding Stone

4000-2/30 High Performance Rotary Tool Kit

- High-performance motor for maximum performance at all speeds
- Electronic feedback for consistent speed under load
- Variable speed for greater versatility
- Can be used with all Dremel accessories and attachments
- Storage Case
- Includes 30 genuine Dremel accessories
- Quick Start Book



Tool Features & Benefits

- High-performance motor for maximum performance at all speeds
- Electronic feedback for consistent speed under load
- Variable speed provides maximum control and precision
- Separate on/off switch and speed control dial for the perfect speed every time
- Can be used with all Dremel attachments and accessories
- Quick collet lock for fast accessory changes
- Cool-running ball bearing construction for smooth and quiet operation
- Replaceable motor brushes extend tool life
- Five year warranty

Specifications

- **Amperage** 1.6 amps • **Cord Length** 6 ft. • **Speed Variable** (5,000 to 35,000 RPM)
- **Voltage** 120 AC, 50-60 Hz • **Warranty** 5 years
- **Weight** (lbs.) 18.8 oz.

Kit Includes

- Dremel 4000 High Performance Rotary Tool • Cicle Cutter/Straight Edge Guide • Sanding/Grinding Guide • Storage Case • Quick Start Book
- 191 High Speed Cutter • 401 Mandrel • 402 Mandrel w/Screw • 407 Coarse 1/2" Sanding Drum • 408 1/2" 60 Grit Sanding Band (2) • 411 3/4" Sanding Disc, 180 grit (3) • 412 3/4" Sanding Disc, 220 grit (3) • 413 3/4" Sanding Disc, 240 grit (2) • 414 Felt Polishing Wheel • 420 Heavy Duty Emery Cut-Off Wheel (2) • 421 Polishing Compound • 426 1-1/4" Fiberglass-Reinforced Cut-Off Wheel (2) • 428 Carbon Steel Brush • 429 1" Felt Polishing Wheel • 432 1/2" 120 Grit Sanding Band (2) • 445 1/2" 240 Grit Sanding Band (2) • 541 Aluminum Oxide Grinding Wheel • 561 MultiPurpose Cutting Bit • 84922 Silicon Carbide Grinding Stone • 90962 Wrench • 932 Aluminum Oxide Grinding Stone

300-1/24, 300 Series Variable-Speed

- New, dynamic design for additional comfort and control
- Includes Storage Case and 24 Accessories



Tool Features & Benefits

- Variable speed from 5,000 to 35,000 rpm
- Lightweight design for comfort during prolonged use
- Comfort grip housing for easier handling and better tool control
- "Dove-tail" feature for Dremel-exclusive attachments
- On board tool storage keeps your wrench close at hand
- Click-and-set on/off switch allows precise speed selection
- Cool-running ball bearing construction for smooth and quiet operation
- Replaceable motor brushes extend tool life

Specifications

- **Amperage** 1.15 • **Cord Length** 6' • **Speed Variable** (5,000 to 35,000 RPM)
- **Voltage** 120 AC, 50-60 Hz • **Warranty** 4 years • **Weight** (lbs.) 18.0 oz.

Includes

- 300 Series Variable Speed Rotary Tool • Cicle Cutter Attachment • 191 High Speed Cutter • 401 Mandrel • 402 Mandrel • 403 Bristle Brush • 407 Coarse 1/2" Sanding Drum • 414 Small Felt Wheels (2) • 420 Heavy Duty Emery Cut-Off Wheel (2) • 421 Polishing Compound • 422 Cone Polishing Tip • 426 1-1/4" Fiberglass-Reinforced Cut-Off Wheel • 428 3/4" Carbon Steel Brush • 429 Large Felt Wheel • 430 Coarse 1/4" Sanding Drum • 432 1/2" 120 Grit Sanding Band • 438 1/4" 120 Grit Sanding Band • 442 Carbon Steel Brush • 540 1-1/4" Cut-Off Wheel • 561 MultiPurpose Cutting Bit • 932 Aluminum Oxide Grinding Stone • 952 Aluminum Oxide Grinding Stone • 8193 5/8" Aluminum Oxide Grinding Stone • 85422 Silicon Carbide Grinding Stone

7700-1/15, 7.2V MultiPro Cordless Kit

- 7.2 Vosts for general applications
- Medium duty cordless that goes anywhere
- Compact and lightweight for easier handling and less fatigue.



Tool Features & Benefits

- Two speeds 10,000 and 20,000 rpm to match the proper speed required
- Removable battery pack lets you use additional packs for continuous use
- 3-hour charger with LED light shows proper charging
- Compact and lightweight for easier handling and less fatigue
- Two-year warranty

Specifications

- **Speed** 2-speed (10,000 / 20,000 RPM) • **Voltage** 7.2 V DC
- **Weight** (lbs.) 11 oz.

Kit Includes

- 7.2 V Cordless rotary Tool • Lawn Mower and Garden Tool Sharpener • 3-Hour Battery Charger • Wrench • Instruction sheet • 191 1/8" High Speed Cutter • 401 Mandrel • 402 Mandrel • 403 Bristle Brush • 407 1/2" Drum Sander • 408 1/2" 60 Grit Sanding Band • 414 Felt Wheel • 420 Heavy Duty Emery Cut-Off Wheel • 421 Polishing Compound • 430 1/4" Sanding Drum • 540 1-1/4" Cut-Off Wheel • 932 Aluminum Oxide Grinding Stone • 952 Aluminum Oxide Grinding Stone • 8193 5/8" Aluminum Oxide Grinding Stone • 84922 Silicon Carbide Grinding Stone

290-01 Electric Engraver

Engraves permanently on tools, machinery, hard steel, wood, plastics, ceramics and more. At 7,200 strokes per minute the 115V motor and replaceable carbide steel engraver point do more than just scratch the surface. Stroke adjustment dial on tool regulates engraving depth from fine lines to deep grooves.



Order No. 290	Price	
----------------------	--------------	--

Tool Description	Model No.	Order No.	Price
Single Speed Rotary	100-N/7	1007	
300 Series Variable-Speed	300-1/24	3001240	
High Performance Rotary	4000-2/30	4000230	
MultiPro Cordless	7700-1/15	7700115	

ACCESSORIES AND ATTACHMENTS

SERIES 937:

225-01 Flex-Shaft Attachment

- Easily attaches to corded Rotary Tool
- 36" long with slim 1/2" handpiece
- Accepts up to 1/8" shank accessories.

Model No.	Order No.	Price
225-01	0000225	



2222 Flex-Shaft Tool Holder

Conveniently supports any Dremel Rotary Tool above your workbench

- Clamps to workbenches up to 1-3/4" thick
- Adjusts in height 12" to 42"

Model No.	Order No.	Price
2222	0002222	



Collets

480 481 482 483
1/8" 3/32" 1/16" 1/32"

Model No.	Order No.	Price
480	0000480	
481	0000481	
482	0000482	
483	0000483	



Cut-off Wheels

For use with Mandrel 402

409 .025 thickness 15/16" dia. (36/pk)
420 .040 thickness 15/16" dia. (20/pk)
426 .045 thickness 1 1/4" dia. (5/pk)
(fiberglass reinforced)
540 .0625 thickness 1 1/4" dia. (5/pk)

Model No.	Order No.	Price/Pk
409	0000409	
420	0000420	
426	0000426	
540	0000540	

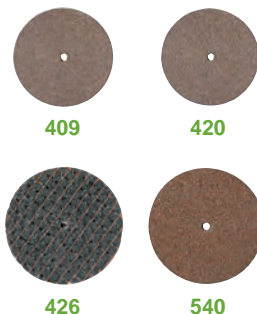

Brush Accessories

Versatile brushes for removing rust and corrosion, also for polishing metal surfaces.

428 442 443
3/4" 1/2" 1/8"

Model No.	Order No.	Price
428	0000428	
442	0000442	
443	0000443	



DREMEL
Tools for the Imagination™

FLEXIBLE SHAFT MACHINES

Series 443:

For Precise or Intricate Hand Grinding, Deburring, Drilling, Polishing, Buffing, or Sanding on Metals, Plastics, and Other Materials

FOREDOM



COMPLETE KITS WITH MOTOR, CONTROL, HANDPIECE AND ACCESSORIES

K.2272, General Applications, 115 Volt.



Includes M.SR hang-up motor, C.FCT foot operated control, H.30 handpiece, 88pc accessory kit, more.

Motor and Speed Control carry a 2 Year Warranty.

Components:

1. Series SR Motor: Foredom's most popular and best motor for general use. The 1/6 hp, ball bearing, hang-up style M.SR runs in forward and reverse at speeds up to 18,000 RPM. It comes equipped with a motor bale for hanging, and our standard 39" long key-tip inner shaft and outer sheath.

Order No. 4432272
Price

2. C.FCT Speed Control: Foredom's most popular foot operated speed control. It has solid state electronics and comes in a heavy duty plastic housing with an extra wide design.

3. H.30 Handpiece: Foredom's most popular general purpose handpiece. It features a 3-jaw, geared chuck with a 0-5/32" capacity. Accessory changes are easy with this handpiece using the supplied chuck key.

4. HPCK-0 Chuck Key in molded plastic handle for changing accessories.

5. AK21 Accessory Kit (88 pc. assortment with 3/32" and 1/8" shank accessories). It includes many unique items from Foredom- Purple Ceramic Sanding Bands and Discs, V Stones, CeramCut Blue Stones, steel cutters and burs, rubber bonded abrasives, mounted abrasive points, wire and bristle brushes, polishing compound and lots more.

6. Flexible shaft grease.

K.SRH440, Industrial Kit with Heavy Duty Shafting, 115 Volt.



Motor and Speed Control carry a 2 Year Warranty.

Components:

1. M.SRH Motor Description: Foredom's 1/6 HP, universal, flexible shaft machine runs in forward and reverse rotation at speeds up to 18,000 RPM. It combines the most important features power, reversibility, reliability, and versatility. This model comes equipped with a motor bale for hanging, and a 63" long, square drive shaft and heavy duty protective sheath. Heavy duty flex shafts are the ultimate power tools for deburring, buffing, grinding, polishing and metal finishing of any kind with larger rotary accessories. They are great for large scale woodcarving and sculpting applications with carbide or steel burs and larger mounted grinding stones.

Order No. 4432590
Price

2. C.SCT-1 Speed Control Description: The C.SCT-1 offers the same solid state electronics and smooth control as the C.FCT-1 but in a much heavier, cast iron housing. The added weight eliminates any unexpected movement of the control along the floor. The bottom surface of the speed control is covered with non-skid material.

3. H.44HT Handpiece: This special square drive, collet style handpiece is for exclusive use with our Series TXH, SRH and LXH heavy duty flex shafts. It comes with 1/8" and 1/4" collets. The tapered design allows for close and safe work.

4. AKHK25: This 10-pc accessory kit includes 2 aluminum oxide points, 2 CeramCut Blue stones, 1 carbide bur and 5 different mandrels for grinding wheels and cartridge rolls. All with 1/8" shanks.

5. Flexible shaft grease and spare motor brushes.

While we show only the popular **DREMEL** items we can supply their entire range of products; please inquire.

While we show only the popular **FOREDOM** items we can supply their entire range of products; please inquire.

SPECIALTY FLUIDS

MACHINIST JACK
SERIES 508:



**"LITTLE GIANT"
JACK SCREWS**
STARRETT SERIES 190, 191:



- Base is made of heavy cast steel.
- Adjustable screw and tilting swivel head.
- Range: 3-4"/75-100mm
- Approximately 1"/25mm adjustment
- 1000 lb. lifting capacity.
- For use on various machine tools or wherever leveling is necessary.

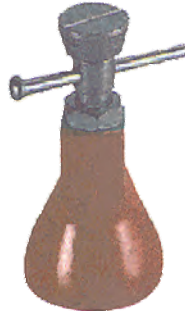

For leveling work on planer beds, upright drills and setting up machinery. The versatility of this tool is greatly increased by the number of attachments available.



- Ability to lift 1,000 lbs. or more.
- 20-pitch screws for fine adjustments.
- Can be used on uneven and round surfaces.

Order No. 5080001	
Price	

Catalog No.	EDP Order No.	Description	Price
Range 2-1/4" - 3-3/8"			
S190	50680	Set Complete with all Attachments	
Range 1-1/2" - 2-1/4"			
S191	50687	Set Complete with all Attachments	

HEAVY DUTY SET INCLUDES:

- Jack, extension bases & attachments.
- Range: 2-1/4 - 3-3/8"mm / 75-100mm

Order No. 5080150	
Price	

**HEAVY DUTY "INDUSTRIAL"
BENCH GRINDERS**
SERIES 508:

We also distribute **BALDOR** grinders. See our website or inquire.

See page 725 for **JET** grinders.



- Pre-lubricated and enclosed ball bearings ensure smooth operation under full load.
- Complete with eye shields, spark shields, adjustable tool rests, fine & coarse wheels.



Model No.	BG6	BG8	BG10
Wheel Size	6" x 3/4" x 1/2"	8" x 3/4" x 5/8"	10" x 1" x 1"
Motor / Electricals	1/3 HP, 1PH 110V	3/4 HP, 1PH 110V	1-1/2 HP, 1 PH 110V
RPM	3450	3450	1720
Weight	27 lbs.	53 lbs.	93 lbs.
Order No.	2585706	2585708	2585710
Price:			

CARBIDE TOOL GRINDER
SERIES 508:



Uses standard 6" x 1" x 1-1/4" plate mounted green silicon carbide or diamond wheels (supplied with white aluminum oxide plate wheels). Adjustable light swings over either wheel.

Precision built to do precision grinding - easy to operate. Vibration is virtually eliminated - armature dynamically balanced : wheels mount very close to oversize O4 ball-bearings; extra heavy 3/4" diameter shaft.

Motor supplied with heavy duty switch. Single phase grinder powered with capacitor run motor, no auxiliary moving parts - won't burn out even under repeated overloading. Protractor type tool support sets in slot of big 4-1/8" x 11-3/4" tool tables. Protractor at each end of grinder indicates angle (up to 45°) of tiltable tool tables. Water pot with spout and faucet - can be mounted over either wheel on support provided on both guards; two large water pans. Shipping weight : 110 lbs.



HP	RPM	Motor	Order No.	Price
1/2	3450	115V/1 Phase	5080000	

**SEE OUR GRINDING AND
DIAMOND WHEELS IN THE
ABRASIVE SECTION.**



While we show only the popular **KI** items we can supply their entire range of products; please inquire.

7" CUT-OFF SAW - 1 HP



Model K7B
Handles 1" solid round, 2" pipe. Adjustable work length stop and down stop furnished. 1/2" wheel arbor. Cast iron base rigid alignment. Dimensions - L 22 x W 10 x H 14.

1 HP TEFC motor, 1 PH (110 / 220V). With cord and switch. Less abrasive wheel. 75 lbs. Spindle RPM 4800.

Order No. 3490007	Price	
-------------------	-------	--

10" CUT-OFF SAW - 3 HP

- Big job capacity: 1-1/2" Solids, 2-1/2" Pipe.
- Swivel vise opens 4" - fast, lever-lock.
- 5/8" arbor, sealed-for-life bearings.
- Cast iron base rigid alignment.
- Dimensions - L 23 x W 10 x H 14.

Optional heavy steel floor stand and foot-operated chain vise (in place of swivel vise).

Model K10B 3HP TEFC motor, 1 PH (110/220V) or 3 PH (220/440V). Please specify voltage. With switch and vise. Less abrasive wheel. 110 lbs. Spindle RPM - 3450.



Model No.	Phase	Description	Order No.	Price
K10B-1	1	10" Saw, bench model, swivel vise, 120 lbs.	3490101	
K10B-3	3		3490103	
K10S-1	1	10" Saw, Steel Stand, swivel vise, 165 lbs.	3491101	
K10S-3	3		3491103	
K10SF-1	1	10" Saw, Steel Stand, Chain vise, 170 lbs.	3492101	
K10SF-3	3		3492103	
K10SW-1	1	10" Saw, WetTop Stand, swivel vise, 190 lbs.	3493101	
K10SW-3	3		3493103	

SERIES 349:

See following pages for **JET** saws, sanders & grinders.

1", 2" & 4" BELT SANDERS

Model 1SM
1" Belt Sander
• 1/3 HP motor, 1 PH
• 1725 RPM
• 1" x 42" belt
• 4" contact wheel
• Tilt table
Vertical sander only.
1800 SFPM., Wt. 32 lbs.



Order No. 3490001	
Price	

Model 2FSM
2" Sander
1/2 HP motor, 1 PH, 3450 RPM.
2" x 48" belt, 5" contact wheel, tilt table and removable platen. Full hinged guard for quick belt change. Vertical or horizontal position.
4500 SFPM., Wt. 48 lbs.



Order No. 3490002	
Price	

Model S4S
4" Sander
The all-purpose sander for metal, wood and plastics. Use in vertical or horizontal position.
1/2 HP, 1 PH TEFC motor. 3450 RPM.



4" x 36" belt with full OSHA guard, easy opening side door for belt change. Wt. 50 lbs.

Order No. 3490004	
Price	

Model S4 sander without full safety guard. Wt. 46 lbs.

Order No. 3490014	
Price	

6" BELT SANDER & STAND



Model S6MS
6" Belt Sander with stand
• 6" x 48" belt
• Direct drive (coupling)
• Quick-belt release
• Heavy-duty steel stand
• 1PH, or 3PH
• Manual switch
• 3500 SFPM
• Cast-iron table 6" x 10"
• Weight 230 lbs.
• Variable position
• Cast-iron frame
• Full safety guard
• 3 HP motor- 3450 RPM
• Reversible platen (6-1/2" x 14")
• 1/2" x 1/8" slot

Model No.	Phase	Order No.	Price
S6MS-1	1	3490061	
S6MS-3	3	3490063	

COMBINATION GRINDER/ SANDER



Model 1SK6
Combination Sander
Two machines in one. 6" bench grinder. (1/3 HP 110V) with a 1" x 42" belt sander. Use in vertical or horizontal position. Has tilt table, contact wheel, removable platen. 3450 RPM. Wt. 32 lbs.

Order No. 3490016	
Price	

DISC SANDER



Model DS10
• Heavy-duty, all steel. Wt. 48 lbs.
• Tilt table, 45° down, 15° up.
• Optional MG10 mitre gauge.
• 10" aluminum disc, 5/8" arbor.
• 6" x 11" table.
• 1/2 H.P., 110/220V, 1PH. TEFC motor.

Order No. 3490010	
Price	



BENCH GRINDERS / BELT & DISC SANDERS

SERIES 179:



BENCH GRINDERS



Includes 2 year warranty.

Order No.	577101	577102	577103
Model No.	JBG-6A	JBG-8A	JBG-10A
Shaft Diameter (in.)	1/2	5/8	1
Wheel Diameter (dia. x w/in.)	6 x 3/4	8 x 1	10 x 1
Wheel Speed (RPM)	3,450	3,450	1,725
Wheel Grits	36/60	36/60	24/46
Overall Dimensions (l x w x h/in.)	18 x 8-1/2 x 10-1/2	19 x 10 x 12-1/2	24-1/2 x 13 x 12-1/4
Motor	1/2 HP 115V 1Ph	1 HP 115V 1 Ph	1-1/2 HP 115V 1Ph
Net Weight (lbs.)	37	59	110
List Price			

FEATURES AND BENEFITS

- UL listed
- Totally enclosed pre-lubricated ball bearings
- Heavy-duty guarded toggle switch on 8" and 10"
- Rubber mounts prevent movement

STANDARD EQUIPMENT

- Cast iron wheel guards and dust vents
- One-piece quick adjusting spark guards
- Large eye shields with quick adjustment
- Adjustable tool rests
- Fine and coarse vitrified grinding wheels

If you have things that need cleaning, sharpening, buffing, removing rust, or removing burs from metal, then you need a grinder. JET Industrial Bench Grinders feature heavy duty construction with powerful, long-life motors for use all day, every day.

Pedestal Stand available; please inquire.

Please inquire for possible "promo" pricing.

1 x 42" BENCH BELT & DISC SANDER

FEATURES AND BENEFITS

- Hinged idler wheel cover
- Power take off, allows for mounting an optional flex shaft, can be used for carving, drums sanding, deburring and dozens of other jobs
- Deluxe miter gauge turns and locks for common angles 45° left and right
- Abrasive belt unit does the work of a jig-saw, copying saw or hand file while removing material and finishing at the same time, allows the operator to get into small openings plus handle odd shapes and angles
- Removable platen allows for sanding, grinding or finishing of outside curves or odd shaped work pieces on the belt



Includes 2 year warranty.

Please inquire for possible "promo" pricing.

Order No.	577003
Model No.	J-4002
Belt Size (w x l / in.)	1 x 42
Belt Speed (SFPM)	3000
Belt Table Size (in.)	6-1/8 x 7-1/8
Belt & Disc Table Tilt	45° out
Disc Diameter (in.)	8
Disc Speed (RPM)	1725
Disc Table Size (in.)	4 x 10
Dust Collection Outlet Diameter (in.)	1-1/2
Machine Dimensions (w x d x h / in.)	21 x 22 x 14
Motor	1/3HP, 115V, 1PH
Net Weight (lbs.)	80
List Price	

2 x 42" BENCH BELT & DISC SANDER

FEATURES AND BENEFITS

- Deluxe miter gauge that turns and locks for common angles, 45° both left and right
- Hinged idler wheel cover
- Abrasive belt unit does the work of a jig saw, coping saw or hand file while removing material and finishing at the same time, allows the operator to get into small openings, plus handle odd shapes and angles
- Allows for sanding, grinding or finishing of outside, curves or odd shaped work pieces on the belt
- Grind, sand or finish large work pieces on the disc unit fast and efficiently, combined with the tilting table, the operator has the advantage of chamfering or beveling, table is slotted to accept miter gauge



Includes 2 year warranty.

Please inquire for possible "promo" pricing.

Order No.	577004
Model No.	J-41002
Belt Size (in.)	2 X 42
Belt Speed (SFPM)	3,100
Belt Table Size (in.)	10 X 6
Belt & Disc Table Tilt	0 to 45°
Disc Diameter (in.)	8
Disc Speed (RPM)	3,450
Disc Table Size (in.)	10-3/4 X 7-1/2
Dust Collection Outlet Diameter (in.)	1-1/2
Machine Dimensions (w x l x h / in.)	20-1/2 X 22-3/4 X 20
Motor	3/4 HP, 115V, 1 Ph
Net Weight (lbs.)	60
List Price	

(Continued)



INDUSTRIAL COMBINATION BELT & DISC FINISHING MACHINES

FEATURES AND BENEFITS

- Belt operates at any angle
- Powered by a heavy duty 1-1/2 HP TEFC motor
- Contour finishing, mitering, flat finishing, beveling and precision finishing
- Plain and compound miters are easily obtained by using the standard die cast aluminum miter gauge
- Fully machined, balanced disc runs vibration free

Includes 2 year warranty.



Please inquire for possible "promo" pricing.

Order No.	414551	414552	414553
Model No.	J-4200A	J-4200A-2	J-4202A
Belt Size (w x l/ in.)	6 x 48	6 X 48	6 x 48
Belt Speed (SFPM)	2850	2850	2850
Belt Table Size (in.)	7-3/8 X 14-3/4	7-3/8 X 14-3/4	7-3/8 X 14-3/4
Belt Table Tilt	45° Out, 20° Platen	45° Out, 20° Platen	45° Out, 20° Platen
Disc Size (in.)	12	12	12
Disc Speed (RPM)	1960	1960	1960
Disc Table Size (w x l/ in.)	12 x 16-3/8	12 x 16-3/8	12 x 16-3/8
Disc Table Tilt	45° out, 20° in	45° out, 20° in	45° out, 20° in
Meter Gauge Groove (in.)	3/8 X 3/4	3/8 X 3/4	3/8 X 3/4
Motor	1-1/2HP, 115V, 1Ph	1-1/2 HP, 230V, 1 Ph	1-1/2 HP, 230V, 3Ph
Net Weight (lbs.)	327	327	324
List Price			

COMBINATION BELT & DISC FINISHING MACHINE

FEATURES AND BENEFITS

- 6" x 48" Belt
- 10" Disc
- Two cast iron tilting tables for mitering applications
- Full access to the belt when tilted in the horizontal position
- Dust collection shrouds on belt and disc

Includes 2 year warranty.



Please inquire for possible "promo" pricing.

Order No.	414550
Model No.	J-4210K
Belt Size (w x l/in.)	6 x 48
Belt Speed (SFPM)	1650
Belt Table Size (w x l/ in.)	6 x 10-1/2
Disc Size (in.)	10
Disc Speed (RPM)	2100
Disc Table Size (in.)	7-1/2 x 13
Table Slots (in.)	5/8
Table Tilt	45° out
Motor	1HP, 115V, 1Ph
Net Weight (lbs.)	215
List Price	

DISC SANDERS

FEATURES AND BENEFITS

- Tilting table capability adds flexibility of 45° forward and 15° backward on positive lock rack and gear
- Table can be lowered below the disc to accommodate large work pieces
- Direct drive motor
- Low voltage protection switch
- Rigid column and heavy duty base

Includes 2 year warranty.



Please inquire for possible "promo" pricing.

Order No.	577010	577011
Model No.	J-4421-2	J-4421-4
Disc Size (in.)	20	20
Disc Speed (RPM)	1725	1725
Table Size (in.)	27-1/2 x 10-1/2	27-1/2 x 10-1/2
Table Slot (in.)	3/8 x 10-1/2	3/8 x 10-1/2
Table Tilt	45° forward, 15° backward	45° forward, 15° backward
Motor	3 HP, 230V, 3 Ph	3 HP, 440V, 3 Ph
Net Weight (lbs.)	449	452
List Price		



DRILL PRESSES

SERIES 179:



Many more DRILL PRESSES available. See our website or inquire.

15" & 20" STEP PULLEY DRILL PRESSES

Practical light to medium duty drill presses.

STANDARD FEATURES

- Cast iron head
- Large quill allows greater accuracy
- Head casting features a permanently lubricated ball bearing spindle assembly, using four heavy duty ball bearings mounted in an enclosed quill for extended life
- Table tilts 45 degrees
- Large ground steel column diameter for maximum head and table support
- Accurate depth stop for precise hole depths
- 3-3/8" stroke for deep hole applications (J-2550)

STANDARD EQUIPMENT

- 5/8" Drill chuck & arbor



Includes 2 year warranty.

Please inquire for possible "promo" pricing.

Order No.	354401	354400	354402
Model No.	J-2530	J-2500	J-2550
Type	15" Bench	15" Floor	20' Floor
Drills to Center of Circle (in.)	15	15	20
Cast Iron Drilling Capacity (max./in.)	5/8	5/8	3/4
Steel Drilling Capacity (max./in.)	1/2	1/2	5/8
Quill Diameter (in.)	1-7/8	1-7/8	2-1/4
Quill Travel (in.)	3-3/8	3-3/8	4-3/4
Spindle Taper	2 MT	2 MT	3 MT
Separate Number & Range of Spindle Speeds (RPM)	12 (250, 340, 390, 510, 600, 650, 990, 1550, 1620, 1900, 2620, 3100)	12 (250, 340, 390, 510, 600, 650, 990, 1550, 1620, 1900, 2620, 3100)	12 (150, 260, 300, 440, 490, 540, 2220, 2950, 4200)
Overall Table Size (in.)	10 x 10	10 x 10	18-1/2 x 16-1/2
Column Diameter (in.)	2-7/8	2-7/8	3-5/8
Base Size (in.)	11 x 18-1/2	11 x 19-1/2	22-3/4 x 17-3/4
Spindle to Base (in.)	24-1/2	48-3/4	43-1/2
Motor	3/4HP, 115V, 1Ph, 1725 RPM	3/4HP, 115V, 1Ph, 1725 RPM	1-1/2HP, 115V, 1Ph, 1725 RPM
Floor Space Required (LxWxH/ in.)	26 x 13-3/8 x 39	26x13-3/8x63-1/2	34 x 21 x 67
Net Weight (lbs.)	147	167	321
List Price			

15" VARIABLE SPEED DRILL PRESSES

- Speeds from 400 to 5,000 RPM
- Handwheel adjustment sets the speeds
- Large 2-1/4" quill allows greater accuracy
- 3" column diameter for maximum head support
- Full bearing support on quill for maximum spindle stiffness
- 6" stroke for deep hole application
- Accurate depth stop for precise hole depths
- Safety collar
- 1/2" Drill chuck & arbor



For 20" Variable Speed Drill Presses, please see next page.

Includes 2 year warranty.

Please inquire for possible "promo" pricing.

Order No.	354550	354551
Model No.	J-A5816	J-A5818
Type	15" Floor	15" Floor
Range of Spindle Speeds (RPM)	400 to 5000	400 to 5000
Spindle Taper	2 MT	2 MT
Quill Diameter (in.)	2-1/4	2-1/4
T-Slots Number and Size (in.)	2 & 1/2	2 & 1/2
Work Table Weight Capacity (lbs.)	90	90
Column Diameter (in.)	3	3
Drilling Capacity Cast Iron (in.)	5/8	5/8
Drilling Capacity Mild Steel (in.)	1/2	1/2
Quill Travel (in.)	6	6
Table Size (in.)	15-1/4 x 17-3/4	15-1/4 x 17-3/4
Spindle Distance to Base (in.)	47-1/2	47-1/2
Net Weight	387.2	426
Motor	1HP, 115/230V, 1Ph, Prewired 115V	1HP, 220/440V, 3Ph, Prewired 220V
List Price		

Order No.	354020	354024
Model No.	GHD-20	GHD-20PF
Drills to Center of Circle (in.)	20	20
Cast Iron Drilling Capacity (in.)	1-1/2	1-1/2
Steel Drilling Capacity (in.)	1-1/4	1-1/4
Column Diameter (in.)	4-1/2	4-1/2
Distance Spindle to Column (max./in.)	10	10
Spindle Taper	MT-3	MT-3
Spindle Travel (in.) (GHD-20)	5	5
Spindle Travel (in.) (GHD-20PF) Manual	4-1/2	4-1/2
Spindle Travel (in.) (GHD-20PF) Auto	4-1/4	4-1/4
Quill Diameter (in.)	3	3
Spindle Distance to Base (in.)	44-3/8	44-3/8
Spindle Distance to Table (in.)	30-7/8	30-7/8
Table Size (in.)	21-1/4 X 18-1/2	21-1/4 x 18-1/2
T-Slots, Number & Size (in.)	2 & 5/8	2 & 5/8
T-Slot Centers (in.)	9	9
Number of Spindle Speeds	12	12
Range of Spindle Speeds (RPM)	60 to 3,000	60 to 3,000
Motor	2HP, 230V only, 3Ph, 2 Speed	2HP, 230V only, 3Ph, 2 Speed
Floor Space Required (in./L x W x H)	32 x 24 x 71	32 x 24 x 71
Net Weight (lbs.)	660	660
List Price		

20" GEARED HEAD DRILL PRESSES

- Heavy duty design allows a variety of precision drilling applications
- Easy to read internal depth gauge (GHD-20)
- Three power down feeds (GHD-20PF) .004, .007, .01
- Calibrated fine down feed built-in
- Built-in spindle lock
- Head tilts left or right
- Easy accessible table raiser
- Large production table and T-slotted base

Includes 2 year warranty.

Please inquire for possible "promo" pricing.



(Continued)

Many more **DRILL PRESSES** available. See our website or inquire.

20" VARIABLE SPEED DRILL PRESSES

FEATURES AND BENEFITS

- Variable spindle speeds from 300 to 2000 RPM
- External #3 Morse Taper
- Front mounted positive control depth stop
- 6" Quill travel
- Massive 3" quill diameter

The J-2221VS 20" Variable Speed Drill Press is an industrial machine with a 2HP motor. It boasts a variable spindle speed, external MT-3, 6" quill travel, massive 3" quill diameter, and a heavy-duty cast iron design. The table rotates 360 degrees around the column over the machined T-slotted base.



Includes 2 year warranty.

Please inquire for possible "promo" pricing.

Order No.	354221	354223
Model No.	J-2221VS	J-2223VS
Drills to Center of Circle (in.)	20	20
Cast Iron Drilling Capacity (in.)	1-1/4	1-1/4
Steel Drilling Capacity (in.)	1	1
Column Diameter (in.)	4-1/2	4-1/2
Range of Spindle Speeds (RPM)	300 to 2000	300 to 2000
Spindle Travel (in.)	6	6
Spindle Taper	3 MT	3 MT
Quill Diameter (in.)	3	3
Table Size (in.)	18-1/8 X 14-3/4	18-1/8 X 14-3/4
T-Slots Number & Size (in.)	2 & 5/8	2 & 5/8
Table Travel (in.)	32-3/8	32-3/8
Base Working Surface (in.)	15-1/4 x 12-1/16	15-1/4 x 12-1/16
Base Slots Number & Size (in.)	2 & 5/8	2 & 5/8
Motor	2 HP, 1 Ph, 115/220V, Prewired 115V	2 HP, 3 Ph, 220/440V, Prewired 440V
Floor Space Required (L x W x H/ in.)	34-1/4 x 27 x 77-1/4	34-1/4 x 27 x 77-1/4
Net Weight	750	750
List Price		

RADIAL DRILL PRESS

FEATURES AND BENEFITS

- The power train gears and spline shafts are made of the finest quality, heat treated and ground nickelchrome steel, giving extra strength and smoothness to high torque loads
- The spindle is made of finest case hardened steel, for extra strength and wear
- The spindle is supported by double row taper roller and thrust ball bearings at the nose, with thrust and radial axis bearings at the top
- Build to withstand exceptionally heavy drilling and boring loads to insure maximum accuracy
- Arm raising safety device prevents arm from dropping
- Counter balanced mechanism for spindle return
- 6 Speeds/3 Feed rates make exotic materials easier to drill, bore and tap
- Centralized control center
- Automatic tool ejector
- Independent arm electric clamping system, which locks and unlocks the head and column
- Push button controls are all reduced to 110VAC
- Electrical circuits are located in the build-in control box at the rear of the arm. This keeps the controls dust-and-humidity-free while making them easily accessible for maintenance
- Entire frame is made of Meehanite and high tensile strength cast iron to handle the heaviest of jobs
- Build in work light
- Coolant pump
- Tool kit
- Box table



Larger Radial Drills available. See our website or inquire.

Please inquire for possible "promo" pricing.

Includes 2 year warranty.

Order No.	320033
Model No.	J-720R
Steel Drilling Capacity (in.)	1-1/2
Cast Iron Drilling Capacity (in.)	2
Steel Tapping Capacity (in.)	3/4
Cast Iron Tapping Capacity (in.)	1
Steel Boring Capacity (in.)	2-3/4
Cast Iron Boring Capacity (in.)	4
Column Diameter (in.)	8-1/4
Distance from Column to Spindle (max./in.)	29-1/2
Distance from Column to Spindle center, (max./in.)	8-5/8
Travel of Head (Horizontal/in.)	20-7/8
Distance from base to spindle end, (max/in.)	41-3/4
Distance from base spindle end, (min/in.)	9-5/8
Travel of arm (Vertical/in.)	23-13/16
Table Size (in.)	23-5/8 x 17-1/2 x 15
T-slot Number & Size (in.)	3 & 3/4
Base Dimensions (in.)	49-5/8 x 25-3/16 x 6-9/32
Range of Spindle Speeds (RPM)	6 (88 to 1500)
Feed Rates (IPR)	.002, .004, .006
Motor	3 HP, 230/460V 3Ph, Prewired 230V
Elevating Motor	1HP
Coolant Pump Motor	1/8 HP
Machine Height from Floor (max./in.)	85-7/16
Floor Space Required (l x w x h/in.)	64 x 32 x 85
Net Weight (lbs.)	2970
List Price	



COLD SAW / BANDSAWS

SERIES 179:



Many more COLD SAWS & BANDSAWS available. See our website or inquire.

MANUAL BENCH COLD SAW

FEATURES AND BENEFITS

- Self-centering vise has dual jaws for burr-free cuts
- Sturdy oil bath gear box design
- Magnetic starter with overload protection
- Cutting head swivels up to 45° for miter cuts.



Order No.	414220
Model No.	J-F225
Blade Speed (RPM)	52
Blade Size (mm.)	225
Round at 90° (in.)	2-1/2
Round at 45° (in.)	2
Square at 90° (in.)	2-1/4
Floor Space Required (l x w x h/in.)	30 x 17 x 32
Motor	1 HP, 115V, 1 Ph
List Price	

The J-F225 Manual Bench Cold Saw comes with a 225mm blade for sawing solid steel. With a 1HP motor, manual vise, bronze worm gear, and hardened ground worm screw gear box, this bench cold saw is everything but small.

Please inquire for possible "promo" pricing.

5 x 6" HORIZONTAL / VERTICAL BANDSAW

FEATURES AND BENEFITS

- UL Listed single phase motor
- Exclusive design heavy-duty 14-gauge stand
- Large diameter wheels and built-in handle allows easy movement
- Front legs feature adjustable leveling pads
- Ball bearing supported blade wheel

ACCESSORIES

414301 Bandsaw Blade
1/2" x .025" x 64-1/2" x 14R- Carbon



Order No.	414458
Model No.	HVBS-56M
Round at 90° (in.)	5
Round at 45° (in.)	3
Rectangle at 90° (in.)	5 x 6
Rectangle at 45° (in.)	5 x 3
Vertical Worktable (in)	9-5/8 x 9-1/2
Vise Swivels (deg.)	45°
Blade Size (in.)	1/2 x 0.025 x 64-1/2
Blade Wheel Diameter (in.)	7-3/8
Blade Speeds (FPM)	80, 120, 200
Motor	1/2HP, 115/230V, 1Ph, Prewired 115V
Net Weight (lbs.)	115
List Price	

The JET HVBS-56M Metalworking Bandsaw is UL listed and powered by a 1/2 HP motor. 2 large diameter wheels and built in handle allow easy movement. Front legs ensure level and accurate cuts by featuring adjustable leveling pads. Each HVBS-56M comes equipped with a 1/2" carbon steel blade, adjustable material stop and vertical worktable. Worried about safety? Don't – the HVBS-56M shuts off automatically after each cut.

Please inquire for possible "promo" pricing.

5 x 8" HORIZONTAL METAL CUTTING BANDSAW

FEATURES AND BENEFITS

- Adjustable hydraulic feed system
- Adjustable ball bearing guides
- Heat treated steel worm gear and bronze driver gear
- Automatic shut off at end of cut
- Handles and wheels for convenient moving to various work stations



Order No.	414453
Model No.	J-3230K
Round at 90° (in.)	5
Round at 45° (in.)	4
Rectangle at 90° (in.)	5 x 7-1/2
Rectangle at 45° (in.)	4-1/2 X 5
Blade Size (in.)	1/2 X .025 X 68-1/2
Blade Speeds (SFPM)	85, 125, 200
Blade Wheel Diameter (in.)	7-1/2
Bed Height (in.)	23-1/2
Motor	1/2 HP, 115V 1 Ph, 1725 RPM
Floor Space Required (l x w x h/ in.)	37 x 16 x 37
Net Weight (lbs.)	165
List Price	

Please inquire for possible "promo" pricing.

(Continued)

BANDSAWS (Continued)

SERIES 179:

JET

JET

Many more BANDSAWS available. See our website or inquire.

7" X 12" HORIZONTAL/VERTICAL BANDSAW WITH COOLANT SYSTEM

FEATURES AND BENEFITS

- UL listed motor
- Heavy cast iron bow and bed
- Hydraulic downfeed for ease of cut
- Hardened and ground worm gear
- Roller cabinet with built-in chip tray
- Automatic shut-off after cut

STANDARD EQUIPMENT

- Complete coolant system
- Adjustable material stop
- Bi-metal variable pitch blade
- Vertical worktable
- Chip Brush

Includes 2 year warranty.



Please inquire for possible "promo" pricing.

Order No.	414459
Model No.	HVBS-7MW
Round Capacity at 90° (in.)	7
Round Capacity at 45° (in.)	4-1/2
Rectangle Capacity at 90° (in.)	7 x 11
Rectangle Capacity at 45° (in.)	5 x 4-1/2
Throat Depth (in.)	7
Vertical Worktable (in.)	9-3/8 x 10
Vise Swivels	45°
Blade Size (in.)	3/4 x .035 x 93
Blade Speeds (SFPM)	80, 130, 180, 285
Blade Wheel Diameter (in.)	11-3/4
Bed Height (in.)	23
Motor	3/4HP, 1Ph, 115/230V, Prewired 115V
Floor Space Required (in.)	20-1/2 x 49-1/2 x 38
Net Weight (lbs.)	330
List Price	

10" X 16" HORIZONTAL BANDSAWS

Order No.	414472	414478	414499
Model No.	J-7020	J-7040	J-7040-4
Round at 90° (in.)	10	10	10
Rectangle at 90° (in.)	9 x 16	9 x 16	9 x 16
Blade Size (in.)	1 x .035 x 135	1 x .035 x 135	1 x .035 x 135
Blade Wheel Speeds (SFPM)	100 - 350	100 - 350	100 - 350
Blade Wheels (in.)	14	14	14
Height of Work Table (in.)	23-1/2	23-1/2	23-1/2
Coolant Tank (gal)	8	8	8
Motor	1-1/2HP, 115/230V, 1Ph, Prewired 230V	2HP, 220V, 3Ph	2HP, 440V, 3Ph
Ship Weight (lbs.)	973	973	973
List Price			

Includes 2 year warranty.



Please inquire for possible "promo" pricing.

FEATURES AND BENEFITS

- Variable Speed drive system
- Exclusive 6 Contact point blade guide assemblies
- Exclusive Swivel control panel
- One piece wheel cover
- Heavy duty, rugged transmission with hardened and ground gears
- Adjustable blade guides with 6 point contact combination bearing and carbide
- Swing away control panel
- Patented 3-jaw rapid-action vise
- Recirculating coolant system standard, 1 GPM pump, 8 gallon reservoir and coolant applied through the blade guides
- Cast iron blade wheels
- 1" Bi-metal blade
- Adjustable material stop.

14" METAL/WOOD VERTICAL BANDSAWS

These saws are specially designed to effectively cut a variety of materials including wood, plastic, bakelite, composites, ferrous and non-ferrous metals. Capable of contour and straight cutting and resawing. Can cut delicate curves in both thick and thin stock.

FEATURES AND BENEFITS

- Cast Iron frame
- Solid, one-piece steel, base for extra stability
- Conveniently located on/off switch
- Exclusive gear box design allows wood/metal model saws to be used for a wider variety of metal, wood, non-ferrous metal and plastic cutting applications
- Miter gauge
- Dust chute
- Saw blades (Wood & Metal)
- Adjustable table

Includes 2 year warranty.



Please inquire for possible "promo" pricing.

Order No.	414500	414504	414502	414503
Model No.	J-8210K	J-8203K	J-8201VS	J-8203VS
Under Guide (in.)	6	6	6	6
Under Guide with Riser Block (in.)	12	12	12	12
Throat Depth (in.)	13-1/2	13-1/2	13-1/2	13-1/2
Blade Size (in.)	3/8x.025x92-1/2	3/8x.025x92-1/2	3/8x.025x92-1/2	3/8x.025x92-1/2
Cutting Speeds Wood (SFPM)	3300	3300	2600	2600
Cutting Speeds Metal (SFPM)	39, 57, 78, 107, 142, 196, 278	39, 57, 78, 107, 142, 196, 278	90-340, 116-334 Variable Speed	90-340, 116-334 Variable Speed
Table Tilt to Right	45°	45°	45°	45°
Table Tilt to Left	15°	15°	15°	15°
Table Height at 90° (in.)	68	68	68	68
Table size (in.)	14 x 14	14 x 14	14 x 14	14 x 14
Miter Gauge Groove (W x D/in.)	3/4 x 3/8	3/4 x 3/8	3/4 x 3/8	3/4 x 3/8
Motor	1HP, 115V, 1Ph, 1725 RPM	1HP, 230/460V, 3Ph, 1725 RPM, Prewired 230V	1HP, 115V, 1Ph, 1725 RPM	1HP, 230/460V, 3Ph, 1725RPM, Prewired 230V
Floor Space Required (L x W x H/ in.)	20 x 16 x 68	20 x 16 x 68	20 x 16 x 68	20 x 16 x 68
Net Weight (lbs.)	280	280	325	325
List Price				



MILLING MACHINES

SERIES 179:



Many more MILLING MACHINES available. See our website or inquire.

BENCH TOP MILLING & DRILLING MACHINES

Shown with optional Stand; please inquire for pricing.

FEATURES AND BENEFITS

- One-piece cast iron column for added support
- Belt cover - quick slide latch allows faster belt adjustment to change spindle speeds
- Base - taper allows for easier clean-up
- Larger hand wheel knobs
- UL listed motor
- Extra large worktable
- Heavy-duty tapered roller bearings support the spindle, resulting in greater tolerance and more accurate drilling depth
- New positive quick-stop knob and easy-to-read internal depth gauge (external on JMD-15)
- Extra large worktable
- 360 degree head swivel
- Heavy-duty power downfeed with manual fine feed (JMD-18PFN)
- Three power down feeds (JMD-18PFN) .004", .007", .01"



Please inquire for possible "promo" pricing.

Packages which include DRO &/or powerfeeds available; please inquire.

STANDARD EQUIPMENT

- Worklamp
- Adjustable carbide face mill
- Drill Press angle vise
- 1/2" drill chuck, chuck arbor
- Draw Bar

Includes 2 year warranty.

Order No.	350017	350018	350020
Model No.	JMD-15	JMD-18	JMD-18PFN
Drill Capacity (in.)	1	1-1/4	1-1/4
Face Mill Capacity (in.)	2-1/2	3	3
End Mill Capacity (in.)	1/2	3/4	3/4
Number of Spindle Speeds	12	12	12
Max Distance Spindle to Table (in.)	15	18	26
Spindle Taper	R-8	R-8	R-8
Quill Diameter (in.)	2-1/2	3	3
T-slots, Number and Size (in.)	4 and 9/16	4 and 5/8	4 and 5/8
Motor	1HP, 1Ph, 115/230V Prewired 115V	2HP, 1Ph, 230V Only	2HP, 1Ph, 230V Only
T-slot Centers (in.)	1-13/16	1-13/16	1-13/16
Distance Base to Spindle	11	11	11
Table Size (in.)	7-1/2 x 23	9-1/2 x 31-3/4	9-1/2 x 31-3/4
Net Weight (lbs.)	457	739	787
Floor Space Required (l x w x h/ in.)	37 x 38 x 37	43 x 40 x 44	42 x 40 x 52
List Price			

JVM-836 VERTICAL MILLING MACHINES

FEATURES AND BENEFITS

- Precision bored and honed milling head
- Large diameter quill is chromed
- High precision spindle bearings
- Over 10" of front to back ram travel
- Locks on all movable surfaces
- Hardened and ground precision table
- Head tilts left or right
- Graduated scale on column
- Precision ground dovetail ways

STANDARD EQUIPMENT

- One-shot lubrication system
- Way Covers
- Draw bar
- Tool box and tools

These small mills have all the features found on our larger mills, but sized for the home shop, repair shops or small maintenance shops.



Packages which include DRO &/or powerfeeds available; please inquire.

Please inquire for possible "promo" pricing.

Order No.	9690036	9690038
Model No.	JVM-836-1	JVM-836-3
Table Size (in.)	7-7/8 x 35-3/4	7-7/8x35-3/4
Spindle Taper	R-8	R-8
Diameter of Quill (in.)	3-3/8	3-3/8
Number of Spindle Speeds	5	5
Range of Spindle Speeds (RPM)	240 - 1,550	120 - 1,550
Spindle Travel (in.)	5	5
Head Movement	90° R & L	90° R & L
Distance Spindle to Table (max./in.)	13-3/4	13-3/4
Distance Spindle to Column (min./in.)	5-1/4	5-1/4
Distance Spindle to Column (max./in.)	15-3/4	15-3/4
Longitudinal Table Travel (in.) (X-axis)	22-1/4	22-1/4
Cross Travel (in.) (Y-axis)	9-1/2	9-1/2
Collet Capacity (in.)	1/8 - 7/8	1/8 - 7/8
T-Slots, Number & Size (in.)	3 and 5/8	3 and 5/8
T-Slot Centers (in.)	2-1/2	2-1/2
Maximum Weight of Workpiece (lbs.)	500	500
Travel of Knee (in.) (Z-axis)	14	14
Travel of Ram (in.)	10-1/2	10-1/2
Motor	1-1/2HP, 1 Ph, 115/230V Prewired 115V	1-1/2HP, 230V, 3Ph Prewired 115V
Overall Dimensions (in./WxDxH)	55 x 52 x 78	55 x 52 x 78
Net Weight (lbs.)	1544	1544
List Price		

(Continued)

SERIES 179:

Many more MILLING MACHINES available. See our website or inquire.



JTM-1 JTM-2 VERTICAL MILLING MACHINE

FEATURES AND BENEFITS

- VERTICAL MILLING MACHINES - JTM-1/2
- Meehanite casting
- Precision bored and honed milling head
- Large diameter quill is chromed
- High precision Class 7 spindle bearings
- Spindle head is internally cooled
- Satin chrome finished dials
- Heavy-duty splined motor drive
- One-piece quill pinion and shaft
- Three-stage power downfeed with automatic stop
- Heavy-duty spindle brake
- Precision hardened and ground ways
- Precision ground table
- Adjustable gibs throughout
- Internal coolant tank built into base for use with coolant system (Coolant pump not included)
- Tolerance test sheet included
- One-shot lubrication system
- Way covers
- Draw bar
- Tool box with tools



Includes 2 year warranty.

Jet's Step Pulley milling machine is the perfect solution for maintenance shops, repair shops, job shops, schools and light production.

Packages which include DRO &/or powerfeeds available; please inquire.

Please inquire for possible "promo" pricing.

Order No.	690082	690089
Model No.	JTM-1	JTM-2
Table Size	9 x 42	9 x 42
Spindle Taper	R-8	R-8
Quill Diameter (in.)	3-3/8	3-3/8
Number of Spindle Speeds	16	8
Range of Spindle Speeds (RPM)	80 - 5440	80 - 2720
Downfeeds of Spindle (IPR)	.0015 - .003 - .006	.0015 - .003 - .006
Spindle Travel (in.)	5	5
Head Movement (degrees)	90 R & 45 F & B	90 R & 45 F & B
Distance Spindle to Table (max./in.)	17-1/2	17-1/2
Distance Spindle to Column (min./in.)	4-1/2	4-1/2
Distance Spindle to Column (max./in.)	19	19
Longitudinal Table Travel (in.) (X-axis)	23-7/8	23-7/8
Cross Travel (in.) (Y-axis)	12-1/2	12-1/2
Collet Capacity (in.)	1/8 - 7/8	1/8 - 7/8
T-slots, Number & Size (in.)	3 and 5/8	3 and 5/8
Overall Dimensions (w x d x h/ in.)	57 x 64 x 82	57 x 64 x 82
Motor	2HP, 230V, 3Ph	2HP, 115/230V, 1Ph, Prewired 230V
Net Weight (lbs.)	2200	2200
List Price		

Note: Use of static phase converter will void warranty

JTM-4VS VARIABLE SPEED VERTICAL MILLING MACHINE

FEATURES AND BENEFITS

- Variable speed vertical milling machines JTM-4VS
- Meehanite casting
- Precision bored and honed milling head
- Large diameter quill is chromed
- High precision Class 7 spindle bearings
- Chrome plated motor shaft with lower bearing support
- Spindle head is internally cooled
- Satin chrome finished dials
- Heavy-duty splined motor drive
- One-piece quill pinion and shaft
- Three-stage power downfeed with automatic stop
- Heavy-duty spindle brake
- Locks on all movable surfaces
- Precision hardened and ground ways and table
- Adjustable gibs throughout
- Internal coolant tank built into casting base for use with coolant system (Coolant pump not included)
- Tolerance test sheet included
- One-shot lubrication system
- Way covers
- Draw bar
- Tool box with tools



(Shown with optional DRO & Powerfeed).

Please inquire for possible "promo" pricing.

Includes 2 year warranty.

Packages which include DRO &/or powerfeeds available; please inquire.

Note: Use of static phase converter will void warranty

Order No.	690180	690182
Model No.	JTM-4VS-1	JTM-4VS
Number of Spindle speeds	Variable	Variable
Spindle Taper	R-8	R-8
Quill Diameter (in.)	3-3/8	3-3/8
Head Movement (deg.)	90°R & L, 45° F & B	90°R & L 45° F & B
Max Distance Spindle to Table (in.)	17-1/2	17-1/2
Distance Spindle to Column (in.)	19	19
Table Longitudinal Travel (in.)	34 (maximum travel)	34 (maximum travel)
Table Cross Travel (in.)	12	12
T-Slots Number and Size (in.)	3 and 5/8	3 and 5/8
T-Slot Centers (in.)	2-1/2	2-1/2
Work Table Weight Capacity (lbs.)	660	660
Travel of Knee (in.)	14-1/2	14-1/2
Travel of Ram (in.)	13-3/8	13-3/8
Quill Travel (in.)	5	5
Quill Down feed Rates (IPR)	.0015-.003-.006	.0015-.003-.006
Range of Spindle Speeds (RPM)	60-4,200	60-4,200
Table Size (in.)	9 x 49	9 x 49
Distance Spindle to Column (min./in.)	4-1/2	4-1/2
Overall Dimensions	65-1/2 x 63 x 85	65-1/2 x 63 x 85
Motor	2HP, 115/230V, 1Ph, Prewired 230V	3HP, 230/460V, 3Ph, Prewired 230V
Net Weight (lbs.)	2420	2420
List Price		



LATHES

SERIES 179:



Many more LATHES available. See our website or inquire.

13 x 40" BELT DRIVE BENCH LATHE

- Enclosed gearbox design provides smooth, quiet operation
- Fast, easy speed changes
- Low voltage motor controls
- Helical cut headstock gears reduce noise
- Change gears allow metric threading
- Spindle is supported by precision tapered roller bearings
- V-way bed is induction hardened and ground
- Gap bed section provided for large diameter work
- Independent leadscrew and feed rod
- T-slotted compound slide with four-way tool post
- Carriage mounted spindle control lever
- Automatic feeding and threading are fully interlocked
- Feed selectors travel in grooved ways
- Tailstock may be offset for turning tapers and includes an inch/metric graduated quill
- Oil pan included
- Tolerance test certificate included

Includes 2 year warranty.

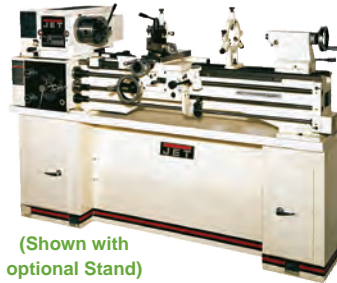

(Shown with optional Stand)

Please inquire for possible "promo" pricing.

Order No.	9321360
Model No.	BOB-1340A
Swing over Bed (in.)	13
Swing over Cross Slide (in.)	7-25/32
Swing over Gap (in.)	18-3/4
Length of Gap (in.)	8
Distance between Centers (in.)	40
Spindle Bore (in.)	1-3/8
Spindle Mount	D1-4
Spindle Taper (with sleeve)	MT-5 (MT-3)
Number of Spindle Speeds	12
Range of Spindle Speeds (RPM)	60 - 1,240
Motor	2HP, 230V, 1Ph
Net Weight (lbs.)	1055
List Price	

Packages which include DRO &/or powerfeeds available; please inquire.

Includes: 3-Jaw & 4-Jaw Chucks, Steady Rest, Follow Rest, 4-Way Tool Post and Face Plate

13 x 40" GEARED HEAD BENCH LATHE

- Enclosed gearbox design provides smooth, quiet operation
- Fast, easy speed changes
- Hardened and ground gears are featured in the headstock and gearbox
- D1-4 spindle is precision ground for accuracy and supported by high quality tapered roller bearings
- Headstock is constantly oiled during operation
- Gear box gives wide inch threading and feed capabilities with no gear changes
- V-way bed design is induction hardened and ground
- Gap bed section provided for larger diameter work
- Independent leadscrew and feed rod
- Spindle actuation control is apron-mounted
- Compound and cross slide have backlash elimination
- Adjustable gibs are incorporated in the carriage and slideways
- Tailstock may be offset for turning tapers and includes an inch-metric graduated quill
- Oil pan included
- Tolerance test certificate included



(Shown with optional Stand)

Please inquire for possible "promo" pricing.

Order No.	9321357
Model No.	GHB-1340A
Swing over Bed (in.)	13
Swing over Cross Slide (in.)	7-25/32
Swing through Gap (in.)	18-3/4
Length of Gap (in.)	8
Distance between Centers (in.)	40
Spindle Bore (in.)	1-3/8
Spindle Mount	D1-4
Spindle Taper (with sleeve)	MT-5 (MT-3)
Motor	2HP, 230V, 1Ph
Net Weight (lbs.)	1,215
List Price	

Includes: 3-Jaw & 4-Jaw Chucks, Steady Rest, Follow Rest, 4-Way Tool Post and Face Plate

Packages which include DRO &/or powerfeeds available; please inquire.

Includes 2 year warranty.

14 x 40" GEARED HEAD ENGINE LATHES

- Hardened and ground gears are featured in the headstock and gearbox
- D1-4 spindle is precision ground for accuracy and supported by high-quality tapered roller bearings
- Headstock is constantly oiled during operation
- Splined, not keyed, shafts are utilized in the headstock
- Gearbox gives large threading and feed capabilities with no gear changes
- V-way bed design is induction hardened and ground
- Gap bed section provided for larger diameter work
- Independent leadscrew and feed rod
- Spindle actuation control is apron mounted
- Inch-metric dials are standard
- Compound and cross slide have backlash elimination
- Adjustable gibs are incorporated in the carriage and slideways
- Tailstock (MT3) may be offset for turning tapers and includes an inch-metric graduated quill
- Tolerance test certificate included
- Heavy-Duty Stand.



Please inquire for possible "promo" pricing.

INCLUDES:
3-Jaw & 4-Jaw Chucks, Face Plate, 4-way Tool Post, Follow Rest, Steady Rest, Full Length Splash Guard, Work Lamp, Foot Brake and Micro Carriage Stop

Packages which include DRO &/or powerfeeds available; please inquire.

Includes 2 year warranty.

Order No.	321830	321840
Model No.	GH-1440W-1	GH-1440W-1
Swing over Bed (in.)	14	14
Swing over Cross Slide (in.)	8-1/2	8-1/2
Swing through Gap (in.)	20	20
Distance between Centers (in.)	40	40
Spindle Bore (in.)	1-1/2	1-1/2
Spindle Taper (with sleeve)	MT-5(MT-3)	MT-5(MT-3)
Number of Spindle Speeds	12	12
Range of Spindle Speeds (RPM)	40 - 1,800	40 - 1,800
No. of Longitudinal and Cross Feeds	40	40
Range of Longitudinal Feeds (in./rev.)	.0012 - .0294	.0012 - .0294
Range of Crossfeeds (in./rev.)	.0003 - .0103	.0003 - .0103
Number, Range of Inch Threads	40, 4 - 112	40, 4 - 112
Number, Range of Metric Threads	22, 0.45 - 7.5	22, 0.45 - 7.5
Maximum Tool Size (in.)	5/8 x 58	5/8 x 58
Max. Compound Slide Travel (in.)	3-1/2	3-1/2
Maximum Cross Slide Travel (in.)	6-3/8	6-3/8
Maximum Carriage Travel (in.)	37-1/2	37-1/2
Tailstock Spindle Travel (in.)	4-3/4	4-3/4
Steady Rest Capacity (in.)	3-3/4	3-3/4
Follow Rest Capacity (in.)	2-3/4	2-3/4
Width of Bed (in.)	10-1/2	10-1/2
Motor	3HP, 230V, 1Ph	3HP, 3Ph, 230/460V, Prewired 230V
Floor Space Required (in./LxWxH)	73-3/4 x 29-1/2 x 47-1/2	73-3/4 x 29-1/2 x 47-1/2
Net Weight (lbs.)	2295	2295
List Price		

MACHINERY & ACCESSORIES

SHOP PRESSES / SHEAR, BRAKE & ROLLS / SLIP ROLLS

SERIES 179:



HYDRAULIC SHOP PRESSES

FEATURES AND BENEFITS

- HYDRAULIC SHOP PRESSES
- For pressing, bending and straightening operations
- Easy-to-use, hand-operated with pressure gauge for direct pressure readings
- Tables raise and lower easily with use of hand crank on the 15-, 35- and 60-ton models
- Side frames are open for inserting long material

Includes 2 year warranty.

Please inquire for possible "promo" pricing.



Order No.	331406	331416	331431
Model No.	HP-5A	HP-15A	HP-35A
Capacity (Tons)	5	15	35
Ram Diameter (in.)	1-3/4	2-1/2	3
Piston Stroke (in.)	4	4-1/2	4-3/4
Screw Stroke (in.)	3	3-1/8	4
Work Table Size (in.)	19 x 5-1/2	24-3/4 x 7-1/2	31 x 10-3/8
Lateral Movement (in.)	-	10-3/16	15
Vertical Table Travel (in.)	15-3/4	22-3/16	23-5/8
Base Size (in.)	23-1/2 x 26	33-7/8 x 29-1/2	33-1/2 x 42
Height (in.)	51-1/2	65-1/2	68
Net Weight (lbs.)	192	435	783
List Price			

COMBINATION SHEAR, BRAKE & ROLL

FEATURES AND BENEFITS

- COMBINATION SHEAR, BRAKE AND ROLL
- Combination shear, brake and roll in one compact machine
- Right or left hand operation
- Shear can be used for mild steel, aluminum, brass, copper, lead, plastic and zinc
- Brake is equipped with easily removable fingers that permit angle, channel, box and other complex bending operations

Includes 2 year warranty.

Please inquire for possible "promo" pricing.



Order No.	754031	754041
Model No.	SBR-30N	SBR-40N
Shearing Capacity (mild steel) (Gauge x in.)	20 x 30	20 x 40
Bending Capacity (mild steel) (Gauge x in.)	20 x 30	20 x 40
Rolling Capacity (mild steel) (Gauge x in.)	20 x 30	20 x 40
Size of Slip Roll (in./L x W)	30 x 1-1/2	40 x 1-5/8
Width of Upper Dies (in.)	1, 2, 3, 6, 8, 10	1, 1-1/2, 2, 2-1/2, 4, 7, 10, 15
Upper Die Height (in.)	4-3/8	3-3/8
Net Weight (lbs.)	300	651
List Price		

Optional stand available; please inquire.

SLIP ROLLS



Please inquire for possible "promo" pricing.

Includes 2 year warranty.

Optional stand available; please inquire.

Order No.	754020	754026	754050
Model No.	SR-2024N	SR-2236N	SR-1650N
Capacity (Mild Steel Gauge)	20	22	16
Max. Forming Length (in.)	24	36	50
No. & Diameter of Rolls (in.)	3 and 2	3 and 2	3 and 3
Min. Forming Radius (in.)	1	1	2
Wire Grooves (in.)	3/16, 1/4, 5/16	3/16, 1/4, 5/16	1/4, 5/16, 3/8
Overall Dimensions (in./l x w x h)	37 x 14-1/2 x 13-3/4	49 x 17 x 17	72-1/2 x 16-1/2 x 19-1/4
Net Weight (lbs.)	216	256	565
List Price			

FEATURES AND BENEFITS

- SLIP ROLLS
- Suitable for many industrial, educational and vocational shop uses
- Precision turned carbon steel rolls that are ground and polished
- Large roll adjusting screws facilitate lifting upper roll for easy material removal
- Wire grooves are standard on SR-2024N, SR-2236N and SR-1650N

ARBOR PRESSES
SERIES 422:

- Heavy duty construction
- Precision made
- 4-way anvil

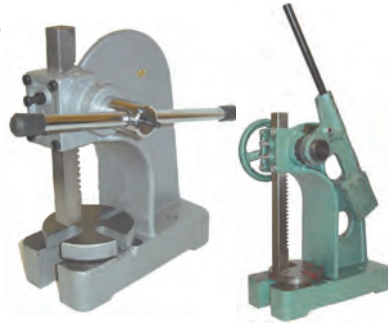

MEGA
Superior Import

Ratcheting
Type

PANAPRESS
SERIES 345:

PANAVISE Made in U.S.A.

Model 502

Ideal for pressing bearings, sleeves, collars, forming and assembling small parts, broaching, staking, etc.

- Reversible ram is 0.75" x 0.75" (19.1mm x 19.1mm) and 5.875" (149.2mm) long and applies up to 1/4 ton (500 lbs/227 kg) of pressure!
- One end of the ram is pre-drilled for adding tooling
- Four adjustable nylon gibs provide exceptional ram control
- Arm is 8" (203.2mm) long.
- Base footprint is 3.7" (94 mm) x 7" (177.8mm) and includes four 0.25" (6.3mm) holes countersunk at the corners for bolting to a work surface.
- Height (from base to top of back-not including variable ram height or arm length): 7" (177.8mm).
Weight: 5.4 lbs. (2.5 Kg).



Order No. 3450502
Price **\$175.99**

Model No.	Tons Pressure	Height Over Table	Height of Press	Base Size	Leverage Ratio	Wt.	Order No.	Price
0	1/2	4-1/2	10	4 x 9-1/2	20:1	25 lbs.	2405000	\$39.50
1	1	5-1/2	13	5 x 11	25:1	40 lbs.	2405001	\$59.75
2	2	8-1/2	18	6-3/4 x 17	35:1	88 lbs.	2405002	\$123.50
3	3	12-1/2	23	8 x 18	50:1	160 lbs.	2405003	\$180.50
5	5	18	35	10 x 26-3/4	50:1	325 lbs.	2405005	\$707.00
Ratcheting Type - For Heavier Applications								
2R	2	8-1/2	18-1/2	6-1/4x15-3/4	-	99 lbs.	2401222	\$185.00
3R	3	12-5/8	21-1/2	8 x 18	-	178 lbs.	2401013	\$315.65
5R	5	18-1/4	34-1/2	11.5 x 26.5	-	380 lbs.	2401015	\$802.50

PHASE-A-MATIC PHASE CONVERTERS
SERIES 222:

Runs three-phase equipment on existing 220V single-phase power

For long heavy starting loads, instant reversing, momentarily overloaded motors, or imported equipment; please inquire. Voltage stabilizer available for high line voltage and voltage-sensitive equipment such as CNC's; please inquire.



STATIC CONVERTERS
(Runs motor loads only at 2/3 rated HP)

How to Size:

The largest motor on your machine must fall within the minimum and maximum range of the converter. Do not order a larger unit or heavy duty model thinking it will give you more horsepower.

When To Use Heavy Duty:

Heavy starting loads (lathes, flywheel driven equip., etc.). Instant reversing, frequent starting, jogging. Air compressors (motor pulley must be reduced by 1/3 diameter).

Heavily Loaded Equipment:

Pumps, fans, blowers, direct-drive compressors, or equipment requiring greater than 2/3 of its rated HP, use a **PHASE-A-MATIC** rotary converter listed below.



For Light to Moderate Loads

Regular Duty Series			
Model No.	Order No.	H.P. Range	Price
PAM-100	2220100	1/3 TO 3/4	\$99.00
PAM-200	2220200	3/4 TO 1-1/2	\$111.00
PAM-300	2220300	1 TO 3	\$123.00
PAM-600	2220600	3 TO 5	\$144.00
PAM-900	2220900	4 TO 8	\$177.00
Heavy Duty Series			
PAM-100HD	2221100	1/3 TO 3/4	\$132.00
PAM-200HD	2221200	3/4 TO 1-1/2	\$147.00
PAM-300HD	2221300	1 TO 3	\$165.00
PAM-600HD	2221600	3 TO 5	\$198.00
PAM-900HD	2221900	4 TO 8	\$240.00
PAM-1200HD	2211200	8 TO 12	\$333.00
PAM-1800HD	2211800	12 TO 18	\$615.00
PAM-3600HD	2213600	20 TO 30	\$837.00
PAM-5000HD	2215000	30 TO 50	\$1257.00

ROTARY CONVERTERS
(For running motor loads greater than 2/3 rated HP)

FEATURES:

- Multi-motor operation
- Multi-speed applications
- Resistive load applications
- No changing motors or switch gear
- Full 12 month warranty
- Easy to install
- No interference to TV, etc.

For larger sizes or 460V operation, please inquire.



Heavy Load Applications

Model No.	Order No.	H.P. Range	Price
R-1	2222001	1	\$432.00
R-2	2222002	2	\$524.00
R-3	2222003	3	\$628.00
R-5	2222005	5	\$820.00
R-7	2222007	7-1/2	\$1076.00
R-10	2222010	10	\$1396.00
R-15	2222015	15	\$1956.00
R-20	2222020	20	\$2368.00
R-30	2222030	30	\$3232.00
R-40	2222040	40	\$4028.00
R-50	2222050	50	\$4760.00
R-60*	2222060	60	\$6460.00
R-80*	2222080	80	\$8056.00
R-100*	2222100	100	\$9520.00

*Multiple Unit Model

QUILL STOP

SERIES 508:



- Quick acting clip easily attaches to quill of Bridgeport® or similar type machines for rapid depth setting
- Top or bottom positioning
- Easily removable



Order No. 2585003	Price	
-------------------	-------	--

QUILL FEED HANDLE

SERIES 508:



Replaces conventional handle for speeding up operations on Bridgeport® type machines.



Order No. 2585001	Price	
-------------------	-------	--

HAND SHEAR MACHINES

SERIES 508:



- Lever type
- Ideal machine for shearing sheet, steel, bars and rods.
- Hardened and tempered replaceable blades.
- Long handles provides plenty of shearing torque.
- Comes with predrilled holes to bolt down to work bench.



Order No.	Blade Length	Weight	Price
5086001	6"/150mm	26lbs/12kg	
5086002	8"/200mm	40lbs/19kg	
5086003	10"/250mm	48lbs/22kg	
5086004	12"/300mm	54lbs/24kg	

TWO-LIFE DRAWBARS

SERIES 508:

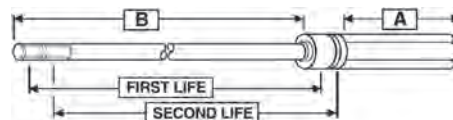

- Two drawbars in one
- Prevents excessive downtime
- Longer hex head & extended thread length
- To obtain "second life" after the end wears out, cut off at "V" notch and remove large spacer

Order No.	Dim. "A"	Dim. "B"	Thread Size	Type of Milling Mach.	Price
5081026	4-1/4	18-1/4	R8 7/16-20	Variable Speed	
5081028	1-1/2	18-1/4	R8 7/16-20	Step Pulley	

CLOCK SPRING ASSEMBLY

FOR MOST BRIDGEPORT® TYPE MACHINES



SERIES 508:

Order No. 5081112	Price	
-------------------	-------	--



MACHINE MOUNTS

SERIES 450:



Effectively Isolate Vibration In Two Ways:

1. By preventing a vibrating machine from transferring vibration to other machines.
2. By insulating precision machinery from external sources of vibration.

Choosing the Correct Royal Machine Mounts. Calculate the load on each mount by dividing the total weight of the machine by the number of mounting locations. Note: sometimes it may be necessary to compensate for machines which do not have an evenly distributed load.

Type	1	2	3	4	5
Order No.	27001	27002	27003	27004	27005
Load Range per Mount (lbs.) General Non-Impact Machinery	100-1,100	880-2,200	1,760-5,500	3,300-8,800	6,600-12,000
Load Range per Mount (lbs.) Presses					
125 strokes/min-max	150-440	440-880	880-3,080	3080-5,940	5,940-8,800
180 strokes/min-max	130-300	260-770	770-2,420	2420-4,290	4,290-7,700
200 strokes/min-max	110-260	260-550	550-1,760	1760-2,860	2,860-5,280
Max. Load per Mount (lbs.) Plastic Injection Molding Machines	390	790	2,180	5,450	8,220
Diameter	3-5/32"	4-3/4"	6-5/16"	6-5/16"	7-7/8"
Height, Including Leveling Plate	1-5/8"	1-15/16"	2-5/16"	2-5/16"	2-23/32"
Over-All Height	5-1/4"	5-1/4"	7-1/2"	7-1/2"	7-7/8"
Level Adjustment	23/32"	23/32"	1"	1"	1"
Leveling Bolt Size	M12x1.25	M16x1.5	M20x1.5	M20x1.5	M20x1.5
Standard Leveling Bolt Length	4-23/32"	4-23/32"	6-11/16"	6-11/16"	6-11/16"
Price Each					



- Royal Machine Mounts meet OSHA requirements by preventing machines from "walking" - without the need for bolting or cementing.
- All mounts incorporate a large, chloro-prene rubber base which is resistant to oil, water, and many chemicals.
- All metal parts are zinc plated for rust protection and long life.
- Support cup is machined from a solid bar instead of deep drawn, resulting in increased thickness and longer life.
- Unique retaining clip ensures that mounts will stay together when machine is moved to a new location.
- Better machine performance and reduced maintenance costs are two of the many benefits of using Royal Machine Mounts.

Stainless steel and zinc plated mounts available; please inquire.

POWER FEED
SERIES 508:



LONGITUDINAL

- New stronger design with polished aluminum housing.
- 110v with manual reset switch.
- Eliminate gear changing.
- Auto cut-off at end of cut.
- Pilot light.

"X" and "Z" Axis Power feeds available; please inquire.



SPECIFICATIONS:

- Speed Range: 1-9" per minute
- Rapid Traverse: 40" per minute
- Torque Rating: 135 lbs/in
- Gearing: Helical

Order No. 5080015	Price	
-------------------	-------	--

ELECTRONIC COUNTER & ELECTRONIC TIME COUNTER
SERIES 257:



- Super compact, large LCD display, long battery life, panel mount, reset.
- Connection: Lead wires, wire-wrap terminals.
- Counter has 30 cycle per second counting speed. Counts to 99,999,999.
- Time counter - elapsed time up to 99,999.99 hours.

Electronic Counter

Order No. 2575000	Price	
-------------------	-------	--



Electronic Time Counter

Order No. 2577500	Price	
-------------------	-------	--

DIGITAL READOUT KITS
SERIES 725:



Digital Z-Axis Readout for Bridgeport® Type Mills



Horizontal



- Can be mounted on almost any surface.
- SPC Output • Resolution .0005" / 0.01mm.
- Accuracy: ± .001" / 0.03mm
- LCD unit displays "E-05" for movement error.
- Includes 2 mounting brackets and EZ mount bracket kit.
- Offers precise linear measurement capabilities.
- One SR44 1.5V battery is supplied.
- Sliding unit can be moved 40" per second.

Range	LCD Horizontal		LCD Vertical	
	Order No.	Price	Order No.	Price
6"/150mm	7250061		7250062	
8"/200mm	7250081		7250082	
12"/300mm	7250121		8250122	
18"/450mm	7250181		8250182	

PRO/CALC® - MATERIAL DIRECTORY & SPINDLE SPEED CALCULATOR
SERIES 508:



Throw out those oil stained charts!

Pro/Calc® takes the guess work out of the question "what RPM should I be using?"

The Pro/Calc® a hand held battery operated reference directory that requires no mathematical computation

It is as easy as 1-2-3

Simply Select:

- 1- Material to be machined (80% of the most used metals)
- 2- Operation: cut-off, form tool, end mills, counterbore, turning, fly-cutting, face milling, tapping, reaming, and drilling.
- 3- Diameter of tool.

The correct RPM will automatically be displayed. (Also displayed are heat treated materials and tap drill sizes.)

Order No. 6000008	Price	
-------------------	-------	--



5-FIGURE DIGIT COUNTER
SERIES 257:



Counts to 99,999. Reset knob for quick "zero" setting. 4 holes in base for easy and rigid mounting. Counter is activated by a 45° movement of the arm. Unit comes with a spring on the lever arm for attaching to machine.

Order No. 1735005	Price	
-------------------	-------	--



39" overall; knee length with full bib and pocket.

Order No. 1915500	
Price	



QUILL KIT
SERIES 572:

Easy Installation Fits Most Vertical Knee Mills

FEATURES:

- Easy to read LCD with resolution of .0005"/0.01mm
- Push button controls for inch/mm, Zero-Set and On/Off
- Powered by a single SR-44 Battery which lasts about 1 year with normal use
- SPC Output for data transmission to Data Processors or LED Remote Display Box



Kit mounted on a vertical mill

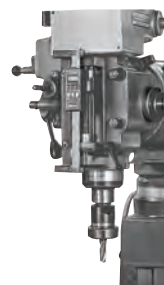

Digimatic Quill Kit complete with brackets & scale for Bridgeport® Type machines.

Order No. 053-906	
Price	

NEW MITUTOYO AOS - DRO SYSTEM KA COUNTER WITH AT - 715 MAGNETIC SCALES

SERIES:

KA Counter

- Selectable Resolutions (.00005, .0001, .0002, .0005") allows choice according to the tolerance requirements of the work being performed
- Bolt Circle Calculation (eliminates need to use trigonometry to calculate hole positions)
- Diameter Mode (doubles reading on cross axis of lathe)
- Tool Offsets (stores datum points for 10 tools which eliminates need to re-zero after tool changes)
- Connectable with AT-715 Magnetic scales or AT-100 series Glass scales (allows use of magnetic and/or glass scales for different applications)
- RS-232 Output (optional) allows data capture and storage on remote computer
- Touch Probe (optional) allows automatic edge detection for zeroing part



AT-715 Magnetic Scales



- Fully submersible in coolant (coolant never effects scale position reading)
- +/- .00012" accuracy over ft./12 in.
- True Absolute (no battery backup - means position information is never lost, even after power interruption)
- Shock Resistant
- Reader Head mounted on saddle guide for easy installation (alignment not as critical)

ABS AOS DRO Linear Scale System SPECIFICATIONS

AT715 Linear scale

Detection system	Electromagnetic induction system (3 tracks, absolute AOS)	
Resolution	0.005 mm / 0.002 mm / 0.001 mm (Changeable by parameter setting) .0005 inch / .0002 inch / .0001 inch / .00005 inch (Changeable by parameter setting)	
Dimensions	Height	1.43" / 36.5mm
	Width	.87" / 22mm
	Length	varies according to travel length specified/ordered
Effective range	3.94" x 70.87"/100 ~ 1800 mm	
Signal output	Mitutoyo original Serial format (can not connect to KL, KLL, KS, KC Counter)	
Accuracy	(7 + 13L / 1000)um [L : Effective range (mm)]	
Maximum response speed	50 m / min.	
CE marking	Corresponding to the regulations	

KA-Counter

Resolution	0.005 mm / 0.002 mm / 0.001 mm (Changeable by parameter setting) .0005 inch / .0002 inch / .0001 inch / .00005 inch (Changeable by parameter setting)
Readout	2-axis, 3-axis (Using 2-axis counter for 1-axis requirement.) (For lathes, using 3-axis counter with the parameter setting changed
Display	Seven segment LED / 7 digit, 1 digit for coordinate number
Main function	Zero setting, Preset, Low digit OFF, 10 coordinate position memory, Bolt-Hole-Circle, mm / inch conversion, Counting direction setting, Resolution setting (Parameter setting), Diameter display, 1/2 calculation, Smoothing display, Tool offsets (Parameter setting)
Input	Automatic discrimination of scale connected ABS AOS DRO scale (AT715 and AT100 series) 2Vpp sine wave
Output	RS-232C interface (Option)
CE marking	Corresponding to the regulations

MAGNETIC ABS - AOS - DRO PACKAGE FOR MILLING SYSTEM

USING KA COUNTER AND AT715 SCALES

2 Axis, KA Counter Milling System

Specify "Package" number when ordering.

	Y Axis Travel			
	AT715-300 (12")	AT715-350 (14")	AT715-400 (16")	
	For Bridgeport #1	For Taiwan	For Lagun	For Taiwan
AT715-750 (30") Axis Travel	Package Number 174-173PM1	Package Number 174-173PM3	Package No.	Package No.
AT715-900 (36") Axis Travel	174-173PM2		174-173PM4	174-173PM5
AT715-1000 (40") Axis Travel		174-173PM6	174-173PM7	174-173PM8

Package Includes:

- KA Counter
- Brackets for Scales
- AT715 Linear Scales
- Display Arm Kit

Order No. 5720001
Price

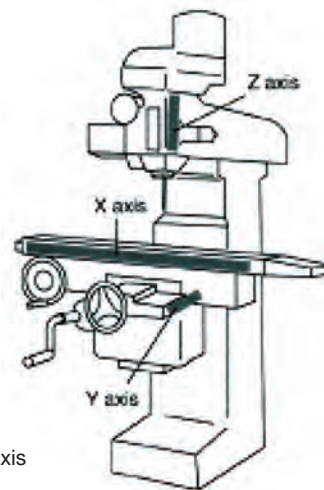

3 Axis, KA Counter Milling System (Z axis length 6")

	Y Axis Travel			
	AT715-300 (12")	AT715-350 (14")	AT715-400 (16")	
	For Bridgeport #1	For Taiwan	For Lagun	For Taiwan
AT715-750 (30") Axis Travel	Package Number 174-175PM1	Package Number 174-175PM3	Package No.	Package No.
AT715-900 (36") Axis Travel	174-175PM2		174-175PM4	174-175PM5
AT715-1000 (40") Axis Travel		174-175PM6	174-175PM7	174-175PM8

Package Includes:

- KA Counter
- Brackets for Scales
- AT715 Linear Scales/ AT715-150mm (6") for Z axis
- Display Arm Kit

Order No. 5720002
Price

AT100 SERIES - GLASS SCALE UNITS

FEATURES

1. Low-priced model AT115

The low-priced version of Mitutoyo Linear Scale AT115 series are available. The mounting dimensions of all the AT115 models are the same as those of the AT111 series. Most suitable for mounting on a milling machine or an XY table.

2. Joint structure of detector

The ball joint structure is employed at the joint of the detector head and the slider (sensor unit) inside the scale. This structure prevents the slider movement from deviating from the normal moving directions when the detector head shifts to right and left, thus providing a normal scale reading and increasing flexibility in the scale installation. In addition, this structure is highly rigid and therefore has an excellent durability.

3. Water-proof connector

A waterproof/splash-proof connector is used to enable separation of the signal cable. Thus, an installation and maintenance of the Linear Scale can be easily performed. (The signal cable in AT115 cannot be separated.)

4. Conduit armored type signal cable

A waterproof/splash-proof connector is used to enable separation of the signal cable. Thus, an installation and maintenance of the Linear Scale can be easily performed. (The signal cable in AT115 cannot be separated.)

5. Unique rubber-lip openings

The rubber-lip openings are shaped like the bottom of a ship that plows the water.

6. Excellent splash and dust-proof rubber lip structure

The rubber lips are made of a strong, special urethane and wires are inserted in these lips to improve the splash-proofing and dust-proofing of the scale. (AT102 only)

GLASS LINEAR SCALE PACKAGE FOR GRINDER SYSTEM

USING KA COUNTER AND AT115

2 Axis, KA Counter Grinder System

Specify "Package" number when ordering.

Vertical	Cross Side			
	AT115-150 (6")	AT115-200 (8")	AT115-250 (10")	AT115-300 (12")
AT115-300 (12")	Package Number 174-173PG1L	Package Number 174-173PG8L	Package Number	Package Number
AT115-350 (14")	174-173PG7L	174-173PG3L	174-173PG5L	
AT115-400 (16")		174-173PG4L	174-173PG13L	
AT115-450 (18")	174-173PG2L	174-173PG9L	174-173PG6L	174-173PG14L
AT115-500 (20")	174-173PG10L	174-173PG11L	174-173PG15L	
AT115-600 (24")	174-173PG12L	174-173PG16L		

Package Includes:

- KA Counter
- AT115 Glass Linear Scale / Magnetic Scale available at same price; please inquire
- Bracket Kits
- Display Arm Kit

Order No. 5720003
Price

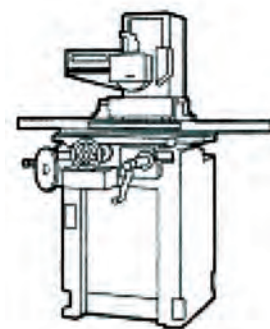

LINEAR SCALE PACKAGES FOR LATHES

2 Axis, KA Counter Lathe System

Package Includes:

- KA Counter
- AT115, AT102 Glass Linear Scale and Extension Cable.
- Bracket Kits
- Counter Stand
- Counter Tray

Z Axis Travel	X Axis Travel		
	AT115-200 (8")	AT115-250 (10")	AT115-300 (12")
AT715-1000 (40")	Package Number 174-173PL3	Package Number 174-173PL4	-
AT715-1200 (48")		174-173PL6	-
AT715-1500 (60")		174-173PL7	174-173PL29

Z-Axis Travel	Order No.	Price
1000	5720004	
1200, 1500	5720005	

Specify "Package" number when ordering.

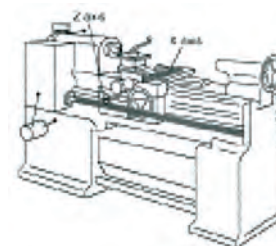



MACHINE SAFETY GUARD SYSTEMS

SERIES 986:



VISORGUARD™

Unbreakable Lexan® Shield Provides Complete Protection Between Cutting Tool and Operator's Eyes.

DOWN-TO-EARTH-FEATURES!

- Flexbar® arm permits setting of Visorguard™ at the correct height and angle for each setup.
- Flip shield up to load part and down for machining.
- Special spring-loaded shaft makes shield stay put - no springback.
- Wing-shaped shield protects workers at adjacent machines.
- Flexbar® locks rigid; has stainless aircraft grade tension cable.
- Can be installed in minutes on CNC mills, conventional milling machines and others.



Dimensions:

- Shield Size - 16" wide X 8" high
- Flexbar arm - 10" long

Model No.	Description	Order No.	Price
13055	Visorguard™ Complete with Mounting Bracket, Flexbar, and all mounting hardware.	8613055	
13050	Long Reach Visorguard™ Up to 40" total reach. Complete with hardware, tube and mounting bracket.	8613050	
13054	Lexan® Shield Replacement for both guards.	8613054	



While we show only the popular **FLEXBAR** items we can supply their entire range of products; please inquire.

LATHEGUARD™



- Ready to mount: affix mounting bracket with two screws.
- Back of shield reinforced with plated wire-form housing.
- Locks in swing away or functional positions.
- Swings away easily
- Heavy Duty Cast Mounting bracket supplied.
- Heavy Duty Chrome-plated extension tube and hardware.

- Clear Lexan®, semi-circular Wrap-a-round Guards.
- Rib reinforced
- Robust construction
- Light in weight

EXCEEDS O.S.H.A. REQUIREMENTS

Model No.	Suggested Lathe Size	Center Height	Use With Chucks	Shield Width	Shield Length	Tube Length	Order No.	Price
12999	Very Small Lathes	3.9"	up to 6" dia.	6-1/4"	7.8"	10"	8612999	
13060	6" to 12"	6"	up to 8" dia.	6-1/4"	11.8"	10"	8613060	
13061	12" to 16"	8"	up to 12" dia.	8"	15.8"	11-1/2"	8613061	
13062	16" to 20"	10"	up to 16" dia.	8"	19.70"	13"	8613062	
13064	20" to 24"	13"	up to 20" dia.	8"	23.6"	13"	8613064	

TRAVELGUARD™

Cross slide type.

Extra-heavy duty O.E.M. type for Lathes, Grinding Machines, etc. Travels with cross slide operator protection wherever tool is cutting.

- Easy to mount on cross slide (tool compound).
- Fully adjustable in all directions- forwards & frontwards.
- Heavy steel construction with thick Lexan® window.
- Frame is 3/4" construction made of heavy gauge steel with high quality painted finish.
- Front panel is hinged and can be lifted for quick access to machine.

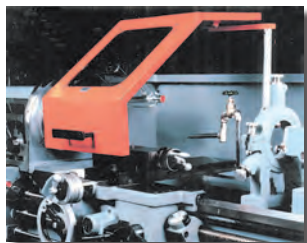

Model No.	Description	Order No.	Price
13086	20" Chuck Max	8613086	
13087	28" Chuck Max	8613087	

THE LEXAN® FLEX-SHIELD

Protects Your Eyes Against Chip & Liquid Burns. Safety Shield on Flexbar® Universal Positioning Arm. Quick Cam Action Locking (Shield swivels 360° and locks positively where placed).

- Overall Height of Flexbar Stand: 14"
- Super Power Disc Mag Base: 3.16" dia.
- Shields made of durable clear view Lexan - 1/8" thick.
- Choice of concave or flat.

Concave Shield Models - Complete

Model No.	Shield Size	Order No.	Price
13313	6" x 8"	8613313	
13314	8" x 10"	8613314	
13315	10" x 12"	8613315	



Flat Shield Models - Complete

Model No.	Shield Size	Order No.	Price
13316	6" x 8"	8613316	
13317	8" x 10"	8613317	
13318	10" x 12"	8613318	

Lexan® Replacement Shields - Carton of 3

Shield Size	Concave			Flat		
	Model No.	Order No.	Price	Model No.	Order No.	Price
6" x 8"	13093-L	8613093		13120-L	8613120	
8" x 10"	13094-L	8613094		13121-L	8613121	
10" x 12"	13095-L	8613095		13122-L	8613122	

PANEL GUARD™

Portable, yet sturdy free-standing guard. Ideal for separating or back guarding machines. Additional panels can be added to cover any size area.

Flexbar Panel Guards™ consist of 4 hinged panels with a pivot spine. Frames are extruded aluminum; inserts are replaceable; lower panels are safety colored, tempered masonite; upper panels are 1/8" thick, high impact resistant, transparent Lexan® Panel Guard™ does not obstruct air circulation or visibility, yet confines chips and oil to machine area for easy cleanup.



Model No.	Description	Order No.	Price
13035	Flexbar Panel Guard™ Basic 4-Panel Set Complete	8613035	
13036	Flexbar Panel Guard™ 2-Panel Expansion Set	8613036	
13037	Flexbar Panel Guard™ Extra Slide-In Flexible Hinge (1 ea.)	8613037	

INDUSTRIAL GLOVES
SERIES 309:



MAGNETIC BASE WITH SAFETY SHIELD
SERIES 309:



All split leather.
"Welders" glove.

Order No. 1915300
Price: \$5.50



Full split leather palm.
Stretch wrist.

Order No. 1915200
Price: \$1.85

Full split leather palm. Leather knuckle guard.
Elastic band for snug fit.

2-1/2" Gauntlet

Order No. 1915000	Price: \$2.15
--------------------------	----------------------

4-1/2" Gauntlet

Order No. 1915100	Price: \$2.90
--------------------------	----------------------



Many other styles of gloves available; please inquire.

- Prevents accidents
- Grips flat or round surfaces
- Fits lathes, grinders, shapers etc
- Provided with crystal clear flat shield
- Shield swivels 360° and locks in place



Size Of Flat Shield		Order No.	Price
6 x 8"	150 x 200 mm	3090580	\$25.80
8 x 10"	200 x 250 mm	3090581	\$27.80
10 x 12"	250 x 300 mm	3090582	\$29.40
12 x 16"	300 x 400 mm	3090583	\$33.00
16 x 20"	400 x 500 mm	3090584	\$35.40
Magnetic base only without shield		3090379	\$22.80

HIGH INTENSITY FLEXIBLE LIGHT TOOLS

SERIES 317:



BEND-A-LIGHT®

- High intensity flexible light.
- Amazing brightness from a 1/8" or 3/16" Dia. High intensity bulb.
- Goes where ordinary lights won't fit.
- Alkaline batteries included.



Model No.	Description	Order No.	Price
16102	11", Mini-Pro, 3/16" Lamp	6016102	\$18.95
10150A	16", Pro, 3/16" Lamp	6010150	\$23.50
15150A	24", Krypton Pro, 1/8" Lamp	6015150	\$45.30

EYELIGHTS HANDS FREE FLASHLIGHT

- Ideal for all professional work
- Batteries included
- The plastic used in Eyelights is flexible.
May be adjusted by bending bows in and out.



Model No.	Description	Order No.	Price
17200	EyeLIGHTS, black, AA batteries	9917200	\$13.25
50103	Replacement bulb	6050103	\$1.15

INSPECTOR™ LIGHTED MIRRORS & ACCESSORIES

- Lighted 1-1/2" x 2-1/2" mirror
- Light floods inspection area
- Thumb controls 90° mirror adjustment
- Makes thorough inspection possible
- 2 (AAA) Batteries Included

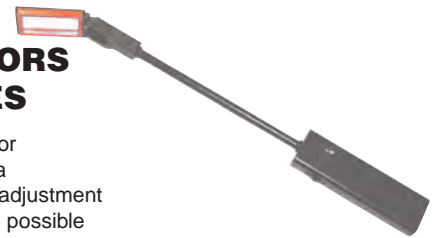

Model No.	Description	Order No.	Price
05100A	18" Rigid shaft adj. mirror 1-1/2 x 2-1/2"	6000031	\$24.65
05180A	18" Flexible shaft adj. mirror 1-1/2 x 1-1/2"	6005180	\$30.05
05240A	24" Flexible shaft adj. mirror 1-1/2 x 2-1/2"	6005240	\$35.15
05420	42" Flexible shaft adj. mirror 1-1/2 x 2-1/2"	6005420	\$40.35
50103	Replacement lamp for 05420	6050103	\$1.15
05154	Replacement 1X mirror 4 x 4"	6005154	\$5.90
05515	Replacement bulb for 05100A, 05180A, 05240A	6005515	\$4.50



While we show only the popular **STEELMAN** items we can supply their entire range of products; please inquire.

LIGHTING

SERIES 958:

MACHINE AND MAGNIFIER LAMPS

SERIES 958:

MAGNIFIER LAMP

- 60 watt, 110 volt, incandescent bulb.
- 4" round magnifier 3x with small 7x magnifier for extra detail.
- 32" swing arm assembly.



Order No. 9580008	
Price	

MACHINE LAMP

- Up to 32" extension.
- 4-way mounting clamp.
- Rated up to 75 watts.
- 360° swivel spring balanced arm of durable construction.



Order No. 9580009	
Price	

MEGA
Superior Import

MAGNETIC LAMP

SERIES 239:

MEGA
Superior Import

Flexible arm allows any projection angle of light. UL power supply cord and 60VA rating. With a powerful high strength ALINCO permanent magnet. Dimension of magnetic base body: L (2.28") x W (2") x H (20.4"). Magnet attraction: 110 lbs.



Order No. 2390013	
Price	

FLUORESCENT FIXTURES

IP67 (WATERPROOF UNDER PRESSURE)

Perfect For Washdown Applications

APPLICATION

These powerful, industrial strength, fluorescent fixtures provide exceptionally bright and natural white light (4100K), over a wide surface area. They are built to endure the harshest machine and industrial environments, including severe levels of water/coolants/ lubricants, vibration, dust and flying metal debris. Ideal for machining centers, inspection stations, presses, EDMs, screw machines and industrial task lighting.

VIRTUALLY INDESTRUCTIBLE ACRYLIC LENS

The "Super Acrylic" outer casing (lens) is remarkably resilient, virtually unbreakable, and lightweight for use in the most hostile environment. It is built to endure extreme vibration while remaining waterproof in the wettest conditions. Optional polycarbonate and borosilicate lenses are available.

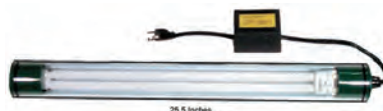

HIGHEST QUALITY

Specifically designed for your machine tool or your production machine. The entire series is rated IP 67 (waterproof under pressure) assuring resistance to moisture and coolant drenching. Secure bulb mounts ignore machine vibration. Standard, off the shelf bulbs are available worldwide offering an average life of 10,000-12,000 hours. "Super Acrylic" lenses resist flying debris and chips. Ballasts are pre-drilled for mounting, easily serviceable, and mounted away from the fixture for maximum operator safety and to ensure long life. Oil resistant (SJT), 25 ft., grounded, cording is standard. All fixtures ship complete with bulb for "Plug 'N Light" installation.



Model No.	Watts	Lgth	Lumen Rating	Rated Hrs	Volts	Hz	Order No.	Price	Replacement Bulb Model No.
FLP-2600	26	10.5"	1500	10,000	120/240	50/60	9582600		PL-C-26W-4
FLP-3600	36	20.5"	2900	12,000	120/240	50/60	9583600		FT36DL /841
FLP-5500	55	25.5"	4800	10,000	120/240	50/60	9585500		Dulux L 55W/21-840
FLP-8000	80	26.5"	6000	10,000	120/240	50/60	9588000		PLL80W841

* All fixtures in the MILLENNIUM SERIES are standard with customer adjustable ballasts

FLUORESCENT GOOSENECK LAMP

WATERPROOF UNDER PRESSURE



APPLICATION

The Series 900 design was created to offer exceptional functionality as well as withstand the harshest machine and industrial environment using heavy coolants and liquids.

This waterproof fixture is virtually shatterproof even in the most hostile environments such as vibration, coolants and liquids, dust, and flying metal debris.

SUPERIOR FEATURES

- Waterproof
- 10-1/2 inch acrylic globe is virtually shatterproof.
- 13 watts rough surface fluorescent, 4100 degree Kelvin bulb offers pure natural white natural light over a large surface area. The rough surface is 10 times more impact-resistant than standard fluorescent bulbs.
- The dual neck system offers "stay-in-place" positioning virtually forever.
- Field proven water-tight base protects the expensive ballast.
- 6 feet of SJT oil-resistant cabling with grounded plug.
- Use standard off-the-shelf Phillips or Osram bulb found easily anywhere in the world.
- Fluted base offers simple mounting.



Model No.	Description	Order No.	Price
FLP-900-20	Beaded Fluorescent Gooseneck 110 volt 13 watt		
OPTIONAL ACCESSORIES			
HLP-29-005 Surface Plate		9580295	
HLP-22 Wall Bracket		9580010	
HLP-23 C' Clamp		9580011	
HLP-30 Magnet Base Assembly (8" x 8")		9580012	
PL13/41CW-RS 13 Watt Replacement Bulb		9580013	
FLP-08 Magnet Cord Holder		9580108	

Model No.	Order No.	Price
FLP-900-20	5890020	

LIGHTING

SERIES 958:



HALOGEN LAMPS (12/24 VOLT VERSION)

IP67 (WATERPROOF UNDER PRESSURE)
IDEAL FOR HOSTILE MACHINE ENVIRONMENTS

Perfect For Washdown Applications

APPLICATION

The new Tough Guy Series (HLP-1000) of Halogen Lighting fixtures are designed and built to meet the demands of the most hostile machine and industrial environments in terms of heavy coolant/lubricants, vibration, and flying metal chips.

SUPERIOR FEATURES

- 5" head is molded as a single piece of extruded aluminum. This offers a waterproof head for maximum reliability in a harsh coolant application.
- Articulated arms, elbow joints, and bases are waterproof, keeping the light dry in even the most hostile coolant and lubricant environments.
- Superior chip-resistant tempered glass lenses offer your operation maximum safety, provides maintenance-free operation, and ease of cleaning. No protective guards are needed that can fracture the light source.
- Large positioning knobs are standard. Once positioned, each light will withstand the most hostile coolant and vibration environment without movement. Up to five points of adjustment. Base offers 320 degree swivel providing accurate light disbursement to the work area.
- Bulbs are easily replaced by removing the front 6 screws and tempered glass lens.
- 70 watt/24 volt halogen bulb is standard with each fixture offering intense white light to the operator and application. Fixtures will also accommodate 70, 50, and 20 watt halogen bulbs. If a 12 volt fixture is required, simply replace the 24 volt bulb with a 12 volt bulb.
- Made of anodized extruded aluminum that won't rust over time and ships standard with 6 feet of SJT oil-resistant cable.
- The Tough Guy 1000 Series of halogen machine tool lights operates with an external 12 or 24 volt transformer or can be wired directly to the 12 or 24 volt outlet in the machine control panel. Operator safety is enhanced without danger of electric shock.

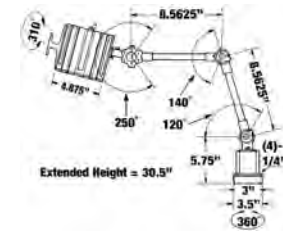

Part No.	Description	Order No.	Price
HLP-1000L	34" Long Arm / Extended Height = 44"	9581000	
HLP-1000M	20" Medium Arm Extended Height = 30.5"	5810001	
HLP-1000S	Short Arm Extended Height = 13.5"	5810002	
HLP-T12/120	Coil Transformer 12/120 Volt	9512120	
HLP-T24/120	Coil Transformer 24/120 Volt	9524120	

Ordering Instructions:
Light & Transformer
purchased separately;
please specify.

Part No.	Description
OPTIONAL ACCESSORIES	
HLP-22-1000	Wall Bracket / Machine Bkt.
HLP-30	Magnet Base Ass'y (8"x8")
FLP-8	Magnetic Cord Holder
HLP-99-1000	Fuse 1.00 / 4
HLP-23	'C' Clamp
BULBS	
HLP-55-H3-12	55 Watt Bulb - 12 volt H-3
HLP-70-H3-24	70 Watt Bulb - 24 volt H-3
HLP-75-B1-12	75 Watt Bulb - 12 volt Bi-pin

HALOGEN GOOSENECK LAMPS

IP54 (Splashproof)

110 Volt Version

APPLICATION

Recommended for dry environments.

SUPERIOR FEATURES

- 35 watts of halogen natural white light standard.
- Transformer built into the base. Fixture can be plugged directly into a 110 volt power source.
- Designed with highly efficient plastic beads over a coaxial cable that hold the light in position vertically forever. Neck will not loosen over time.
- Heavy duty plastic head with on/off switch offers maximum safety.
- Magnets, machine bracket and surface plate available.



Part No.	Description	Order No.	Price
HLP-005-14	Long Neck - 14 Beads - 35 Watts 110 Volts	9580514	\$235.75
HLP-005-20	Extra Long - 20 Beads - 35 Watts 110 Volts	9580520	\$223.95
OPTIONAL ACCESSORIES & BULB			
HLP-24-005	Magnet	9580245	
HLP-29-005	Surface Plate	9580295	
FLP-8	Magenetic Cord Holder	9580108	
HLP-35-MR 16-12 35	Watt Replacement Bulb	9580135	





Made in U.S.A.



Made in U.S.A.

MACHINERY'S HANDBOOK CD-ROM 28TH EDITION

COMBO PACK
(Includes: "Toolbox"
Edition Handbook & CD-ROM)

Order No. 6951000	
Price:	



- Complete text searches to locate information quickly and easily.
- Interlinks to connect to related topics, including a live index.
- Prints correctly on virtually any printing device.
- Text and graphics displayed exactly as created.
- Zoom features for detailed viewing.
- Cut and paste capabilities for inserting text and graphics into other documents and programs.

Minimum System Requirements: 486 PC, Win 95/98/ME/NT/2000/XP, 10MB RAM Win95/98, 16 MB RAM WinNT, 10MB HD CD-ROM drive, VGA monitor.

TABLE OF CONTENTS - HANDBOOK & CD-ROM:

Mathematics • Mechanics • Strength of Materials • Properties, Treatment and Testing of Materials • Plastics • Dimensioning, Gaging, and Measuring • Tooling & Toolmaking • Machining Operations • Manufacturing Processes • Fasteners • Threads & Threading • Gears, Splines, and Cams • Bearings & Other Machines Elements • Measuring Units • Index

CD-ROM

Order No. 6950000	Price	
-------------------	-------	--

CNC PROGRAMMING HANDBOOK, THIRD EDITION

600 pages



This best-selling book has become the de facto standard for training and reference material at all levels of CNC programming. Used in hundreds of educational institutions around the world as the primary text for CNC courses, and used daily by many in-field CNC programmers and machine operators, this book literally defines CNC programming. This extraordinarily comprehensive work is packed with over one thousand illustrations, tables, formulas, tips, shortcuts, and practical examples.

The enclosed CD-ROM also offers many training exercises based on individual chapters, along with solutions and detailed explanations. Special programming and machining examples are provided as well, in form of complete machine files, useful as actual programming resources. Virtually all files use Adobe PDF format and are set to high resolution printing.

FEATURES:

- Fully functional shareware version of CNC toolpath simulator/editor, NCPlot(TM), included on the CD-ROM. This powerful software includes an amazing array of features, including those not found in competitive products. Support for many advanced features is standard, and the included macro interpreter can simulate Fanuc and compatible macro toolpath programs
- Detailed section on CNC lathes with live tooling, including examples
- Image files of many actual parts, used as examples
- More programming examples (both in printed text and on the CD-ROM)
- Optimized for the latest Fanuc and related control systems
- Additional formulas, calculations and handy reference material
- Fourth axis programming (indexing and rotary)
- CD-ROM based projects, including several as interactive PDF forms
- Improved index for better search of topics

Order No. 6953136	Price	
-------------------	-------	--

MACHINERY'S HANDBOOK 28TH EDITION

2,704 pages with thumb index

After more than 85 years of continuous publication, **Machinery's Handbook** remains unchallenged as "The Bible" in its field, and the new 27th edition remains true to the Handbook's original design as an extraordinarily comprehensive yet practical and easy-to-use reference for mechanical and manufacturing engineers, designers, draftsmen, toolmakers, and machinists. While virtually every section has been carefully reviewed and updated to one degree or another, the following are the most notable improvements.

- Nearly 100 pages longer overall than prior editions.
- An expanded table of contents and index to make finding information easier and faster.
- An expanded coverage of speeds and feeds, including new material on grinding.
- A new and innovative presentation on the economics of machining and grinding which is designed to help lower unit manufacturing costs and/or maximize production output in the most cost-effective way.
- An expanded mathematics section, including new coverage of coordinate systems and interpolations.

"Toolbox" Edition (5" x 7")

Order No. 6950001	Price:	
-------------------	--------	--

"Larger Print" Edition (7" x 10")

Order No. 6950003	Price:	
-------------------	--------	--

MACHINERY'S HANDBOOK GUIDE 28TH EDITION

277 pages



Completely updated to reflect the changes and additions made to the Handbook. Throughout the Guide, you will find useful information on how to make full use of the Handbook to solve problems encountered on the job. In addition to offering a wealth of timesaving data that can help in almost any situation, it includes over 500 examples and questions (with answers) specially selected for engineers and apprentices.

Order No. 6950100	Price:	
-------------------	--------	--

POCKET REF

Compiled by Thomas J. Glover over 10 years

Pocket Ref contains an amazing amount of information on an amazing number of topics, including tables, maps, formulas, constants, & conversions. Find helpful everyday information and information that is difficult to locate anywhere. If you can think up a question, there is a great chance the answer can be found in Pocket Ref!

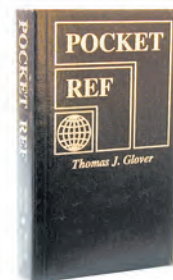

Order No. 6950500	Price	
-------------------	-------	--



INDEXES & STANDS
SERIES 569:



DRILL INDEXES

JOBBERS LENGTH
SILVER & DEMING-1/2" Shank



Model No.	Description	Order No.	Price
313	1/16" to 1/4" x 64ths (single panel) Jobbers Length	5612750	
15	1/16" to 1/2" x 32nds Jobbers length	5610350	
20	No. 61 to 80 inc. Jobbers length	5610400	
21	1/16" to 3/8" x 64ths Jobbers length	5610450	
26	A to Z inc. Jobbers length	5610500	
29	1/16" to 1/2" x 64 ths Jobbers length	5610550	
60	No. 1 to 60 inc. Jobbers length	5610600	
80	No. 1 to 80 inc. Jobbers length	5610700	
10001	Hang-up 1/16" to 1/4" x 64ths Jobbers length	5610001	
88SD	9/16" to 1" by 16ths Silver Deming	5610760	
	15 Silver Deming 1/2" to 23/32" by 64ths	5610761	
	10 Silver Deming 47/64" to 7/8" by 64ths	5610762	
	8 Silver Deming 33/64" to 23/32" by 64ths	5610763	
1316	1/64" to 1/4" x 64ths Jobbers lengths	5610800	
119	Maintenance Index holds: 1/16", 5/64", 3/32", 1/8" #29,#, #25, 5/32", #21,3/16", 7#, 7/32", 1/4" #F, 5/16, #U, 3/8", 27/64", 7/16", 1/2"	5610875	
2100	1/16" to 1/4" x 64ths and 9/32" to 1/2" x 32nds Jobber length	5612300	

METRIC

Order No.	Description	Model No.	Price
4011	1 to 6mm by 0.5mm	5611000	
4013	1 to 7mm by 0.5mm	5611050	
4019	1 to 10mm by 0.5mm	5611100	
4025	1 to 13mm by 0.5mm	5611150	
4041	6 to 10mm by 0.1mm	5611200	
4050	1 to 5.9mm by 0.1mm	5611250	
118	Holds 118 drills from 1.0mm to 13.0mm	5611825	
12765	Holds 1.0, 1.2, 1.5, 2.0, 2.5, 3.0, 3.5, 4.0, 4.5, 5.0, 5.5, 6.0, 6.5	5612765	

TAPER SHANK AND TAPER LENGTH DRILL INDEXES



No.	Model Description	Order No.	Price
1016	33/64" to 3/4" x 64ths taper shank	5610900	
2016	49/64" to 1" x64ths taper shank	5610950	
326	A to Z taper length	5611525	
329	1/16" to 1/2" x 64ths taper length	5611600	
360	No.1 to 60 taper length	5611650	

COMBINATION INDEXES



Model No.	Description	Order No.	Price
115	Holds 115 drills, same as #60, #26, #29, in one case	5611700	
135	Holds 135 drills, same as #20 #60, #26, #29, in one case	5611750	
134	Holds 134 drills, same as #20, #60, #29, #4025 in one case	5611800	
118	Holds 118 drills, from 1.0mm to 13mm	5611825	

STUB SCREW MACHINE DRILL INDEXES



Model No.	Description	Order No.	Price
2013	1/16" to 1/4" x 64ths	5611300	
2021	1/16" to 3/8" x 64ths	5611350	
2025	1 to 13mm by 0.5mm	5611375	
2026	A to Z	5611400	
2029	1/16" to 1/2" x 64ths	5611450	
2060	No. 1 to 60	5611500	
11550	Holds 115 drills: 1/16 to 1/2 x 64th, No. 1-60, A-Z	5611550	

DRILL STANDS AND BURR STAND



Model No.	Description	Order No.	Price
826	A to Z inc.	5611850	
829	1/16" to 1/2" x 64ths	5611900	
833	For jobbers & stub or screw machine length from 1/2" to 1" by 64ths	5611975	
833SD	For Silver Deming drills from 1/2" to 1" by 64ths	5611985	
824	Holds 24 1/4" shank burrs	5611875	

SPECIALTY FLUIDS



INDEXES, STANDS & GAGES

SERIES 569:



TAP/ DRILL INDEXES



Model No.	Description	Order No.	Price
99	Holds 9 drills and 9 taps - NC 6-32, #36 to 1/2"-13, 27/64"	5612600	
18	Holds 9 drills and 9 taps - NF 6-40, #33 to 1/2"-20, 29/64"	5612650	
4099	Holds 9 drills and 9 taps- METRIC 2.5mm x 0.45 tap, 2.05 drill to 12.0mm x 1.75 tap 10.20mm drill	5612675	
36	Holds 18 drills & 18 taps both models 18 & 99 in one case	5612700	

REAMER INDEXES

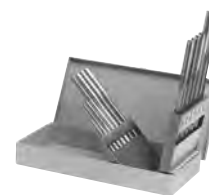

Model No.	Description	Order No.	Price
126	A to Z inc.	5612000	
129	1/16" to 1/2" x64ths	5612050	
160	No. 1 to 60 inc.	5612200	
14	14 Over and Under reamers .124-.126 to .499-.501 by 16ths	5612100	
12125	14 Dowel pin reamers .123 to .4995	5612125	
125	Metric 1.00mm to 13.00mm by 0.5mm	5612130	

STORAGE PRODUCTS

TAP INDEXES



Model No.	Description	Order No.	Price
19	10 taps 0-80 to 12-28 & 9 taps 1-64 to 12-24, 19 total	5612550	
10	5 taps 1/4-20 to 1/2-13 & 5 taps 1/4-28 to 1/2-20, 10 total	5612575	
12590	10 taps 4-40, 6-32, 8-32, 10-24, 10-32, 1/4-20, 5/16-18, 3/8-16, 1/2-13, 5/8-11	5612590	

DRILL GAGES



Model No.	Description	Order No.	Price
9092	1/16" to 1/2" x 64ths	5612250	
12260	1 to 60 wire gauge	5612260	
12280	1/2" to 1" x 64ths	5612280	

SCREW EXTRACTOR INDEX



Model No.	Description	Order No.	Price
55	Holds #1 to #5 screw extractor with matching drill bits	5610200	



While we show only the popular **Huot** items we can supply their entire range of products; please inquire.

NEEDLE FILE INDEX



Model No.	Description	Order No.	Price
10010	Holds 12 assorted needle files for quick selection	5610010	

TAP & DRILL STANDS

SERIES 639:

Easy access to proper Body Drill, Tap Drill, and Tap.



English



Metric

Description	Order No.	Price
English (65 Holes for #2 to 1/2")	6000032	
Metric (45 Holes for 2-14mm)	6000033	



DISPENSERS & TOOL BOX

SERIES 569:



DRILL DISPENSERS



Model No.	Description	Wt.	Order No.	Price
1	For 1/16" to 1/2" X 64ths drills	10 lbs	5613000	
2	For No. 1 to 60 drills	13 lbs	5613025	
3	For A to Z drills	11 lbs	5613050	
4	For metric 1mm to 13 mm by 0.5mm	10 lbs	5613075	
5	For metric 1mm to 6.9 by 0.1 mm	13 lbs	5613100	
84	For #1 to 80 drills 84 compartments	14 lbs	5613040	
13175	For 1/16" to 1/2" x 64ths drills; A to Z, 1 to 60 drills	43 lbs	5613175	
13180	Metric .35 to 2.5mm x .05, 2.6mm to 10mm x .1 common sizes to 13mm	43 lbs	5613180	

REAMER DISPENSERS



Model No.	Description	Wt	Order No.	Price
196	Fractional reamers 1/8" to 1/2", Over/ Under Reamers from .1240 to .5010, Dowel pin reamers from .1230 to .4995	38 lbs	5613400	
13410	1/16 to 1/2 reamers 4 drawer cabinet	12 lbs	5613410	
13415	A to Z size reamers 3 drawer	11 lbs	5613415	
13420	1 to 60 reamers 5 drawer cabinet	13 lbs	5613420	
13430	Over/ Under and Dowel pin reamers	12 lbs	5613430	
13450	Fractional reamers 1/16" to 1/2", Over/ Under Reamers from .1240 to .5010, Dowel pin reamers from .1230 to .4995, Metric reamers 1.0mm to 13.0mm x .5	46 lbs	5613450	

TAP DISPENSERS



Model No.	Description	Wt.	Order No.	Price
13500	For taps 1/4-20 thru 1"-14	10 lbs	5613500	
13550	For taps 2-56 thru 12-28	13 lbs	5613550	
13575	For metric taps 3mm to 24mm	10 lbs	5613575	
13580	Holds 1/4-20 to 1"-14 taper, plug, bottoming & 2-56 to 12-28 taper, plug, bottoming & spiral	50 lbs	5613580	
13585	Holds popular NC and NF taps from 1/4 " to 1-1/2", machine screw sizes 2-56 thru 12-28 and metric 2.5mm to 30mm	50 lbs	5613585	

END MILL DISPENSERS



Model No.	Description	Wt	Order No.	Price
13300	2 Flute single and double end mills 1/16 to 1"	37 lbs	5613300	
13325	4 Flute single and double end mills 1/16 to 1"	37 lbs	5613325	
13350	1/8" to 1" end mills	10 lbs	5613350	
13375	Metric end mills in a 3 drawer Master cabinet 2.0 to 25.0	38 lbs	5613375	

TAP/ DRILL DISPENSER

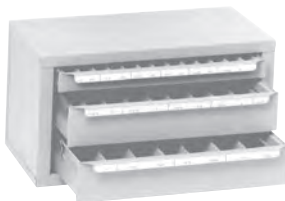

Model No.	Description	Weight	Order No.	Price
1414	For taps and drills from 6-32 #36 to 1/2"-20 29/64"	10 lbs	5613590	

TOOL BOX - HEAVY DUTY

SERIES 451:



Spacious storage compartment and four smooth-gliding cantilever trays. Made of 0.8mm heavy gauge steel. Sturdy construction. Blue baked enamel durable finish. Complete with two padlock eyes on cover for attachment of lock; two heavy easy-grip round handles extending over full length of box.



Size (L x W x h)	Weight	Order No.	Price
16-3/4 x 8 x 8	11 lbs.	2525000*	

*LIMITED QUANTITY

SERIES 451:



Made in U.S.A.

*Please specify color when ordering.

Model 520

7 Drawer Machinist's Chest

- Drawers and top till wool felt-lined
- Vinyl cushioned, steel core top handle
- Six drawer dividers
- 20-1/8" W x 8-9/16" D x 13 5/8" H
- Brown wrinkle finish
- 35 lbs.



Order No. 8410520

Price

Model 52611

11 Drawer Machinist's Chest

- Drop front panel adds security
- Heavy Duty plated side handles
- Eight drawer dividers and wool felt-lined drawers and top till
- 26-11/16" W x 8-9/16" D x 13 5/8" H
- Brown wrinkle finish
- 56 lbs.



Order No. 4152611

Price

Model 266

6 Drawer Mechanist's Chest

- Full length staked chest hinges are securely welded.
- Partitioned top till holds lift-out tray
- Drawers lock when the lid is closed by internal drawer locking system.
- 26-1/8" W x 12-1/16" D x 14-3/4" H
- Brown wrinkle or smooth red finish*
- 58 lbs.



Order No. 8410266

Price

Model 10491

11 Drawer Pro-Line Maintenance Cart With Side Compartment

- Heavy, welded-steel construction
- Huge 39" x 18" MDF work surface
- Side compartment has adjustable MDF shelf and locking door
- Ball-bearing drawer slides
- Includes tubular side handle, aluminum drawer pulls, two keyed alike tubular locks and 5 x 2" roller bearing casters
- 39"-3/8" W x 18" D x 35" H
- High-gloss black powder finish
- 205 lbs.



Order No. 4110491

Price

Model 277 (Bottom)



7 Drawer Roller Chest

- Tamper proof internal drawer locking system...Fully lockable
- Comes with 5 x 1-1/4" casters
- 27" W x 18" D x 35" H
- Brown wrinkle or smooth red finish*
- 138 lbs.

Order No. 8410277

Price

Model 1018

Cantilever Tool Box

- Moveable/removable partitions and divider sets in two trays
- Steel core, vinyl
- 18-1/8" L x 10-1/16 W x 12-5/8" H
- Brown wrinkle finish with tan enamel trays
- 19.5 lbs.



Order No. 8411018

Price

Model 297 or Model 297X

7 Drawer Roller Cabinet

- Tamper proof internal drawer locking system. Fully lockable.
- Comes with 5 x 2" casters
- 29" W x 20" D x 35" H
- Brown wrinkle or smooth red finish*



Model No.	Weight	Order No.	Price
297	158 lbs.	8410297	<input type="text"/>
297X	165 lbs.	8412971	<input type="text"/>

- Model 297 comes with friction slides
- Model 297X comes with ball-bearing slides on all drawers

Model K20

Professional Flat Top Tool Box/20"

- Heavy duty, heavily plated hardware plus rolled and flattened body and lid edges for added strength
- Vinyl cushioned steel core top handle
- Lift-out tray
- 20-1/8" L x 8-5/8 W x 9-3/4 "H
- Brown wrinkle finish with tan enamel tray
- 14 lbs.



Order No. 8410020

Price

While we show the most popular **Kennedy** items, we can supply their entire range of products; please inquire.



MAINTENANCE PRODUCTS

SERIES 906:



PRO-FLEX™ SWEEPS

Strongest sweep on the market, easiest to assemble AND unbreakable!



Block Size	Trim Length	Fill Material	Order No.	Price
24"	3"	Grey Polystyrene Border with Stiff Black Poly Center	44600	
24"	4"	Palmyra	44601	
24"	3-1/4"	Medium Maroon Poly	44604	
24"	3-1/4"	Stiff Blue Poly	44606	

Includes comfort grip handle and scraper

FINE SWEEPING

Lacquered hardwood block. Two threaded handle holes. For sweeping smooth surfaces, tile, wood, linoleum and smooth concrete.



Block Size	Trim Length	Fill Material	Order No.	Price
24"	3"	Black Horsehair	42002	
24"	3"	Silver Poly	942042	
36"	3"	Silver Poly	42098	

Handles Sold Separately

COARSE SWEEPING

Non-absorbent - oil resistant - wash easily. Wet or dry sweeping. Lacquered hardwood block. Two threaded handle holes.



Block Size	Trim Length	Fill Material	Order No.	Price
18"	3"	Black Tampico	42134	
24"	3"	with Wire Ctr.	42135	

Handles Sold Separately

PERMA SWEEP™

Tough synthetic block will not split, crack, or warp. The synthetic fill is chemical and solvent resistant. Wet or dry application.



Block Size	Trim Length	Color	Use	Order No.	Price
24"	3"	Green	Fine	42164	
24"	3"	Yellow	Medium	42166	
24"	3"	Maroon	Coarse	42168	

Handles Sold Separately

HANDLES

Lacquered hardwood. Standard threads.



Length	Dia	Tip	Order No.	Price
60"	15/16"	Threaded Metal	944300	
60"	1-1/8"	Threaded Metal	44435	
72"	15/16"	Threaded Metal	944302	
60"	15/16"	Threaded Wood	44018	
60"	1-1/8"	Threaded Wood	44019	
60"	1-1/8"	Tapered Wood	44020	
60"	15/16"	Perma-Flex Threaded	44301	
60"	1"	Tapered/Threaded Plastic	44561	

HEAVY-DUTY STEEL BRACE



Description	Order No.	Price
Attaches to block with screws and wraps around handle. Fits all handle sizes.	44290	

MEDIUM SWEEPING

Oil resistant. Lacquered hardwood block. Two threaded handle holes. For sweeping semi-rough floors, wood, concrete or brick.



Block Size	Trim Length	Fill Material	Order No.	Price
18"	3"	Black Tampico	42007	
24"	3"	Economy Black Tampico	925232	
24"	3"	Black Tampico	42008	
24"	3"	Economy Black Poly	925235	
24"	3"	Black Poly	42037	

Handles Sold Separately

GARAGE BRUSHES

For wet or dry sweeping on rough concrete or wood floors. Lacquered hardwood block. Two threaded handle holes.



Block Size	Trim Length	Fill Material	Order No.	Price
24"	4"	Economy Palmyra	925242	
24"	4"	Palmyra	942023	

Handles Sold Separately

STREET BROOM

Wide flared ends for sweeping close to curbs and walls. Hardwood block. Two tapered handle holes.



Block Size	Trim	Fill Material	Order No.	Price
14"	4"	White Poly.	70210	

Handles Sold Separately

ANGLE BROOM



Trim Length	Fill Material	Order No.	Price
7-1/2"-6"	Flagged Plastic	944305	

COUNTER DUSTERS - HARDWOOD Blocks



Brush Length	Trim Length	Fill Material	Order No.	Price
8"	2-1/4"	Horsehair	44003	
8"	2-1/2"	Black Poly	925252	

VEHICLE WASH BRUSHES



Block Size	Trim Length	Fill Material	Order No.	Price
9-1/2" x 2-3/4"	2-1/2"	White Poly	44510	
9-1/2" x 2-3/4"	2-1/2"	Green Poly	973146	

Handles Sold Separately

Utility Scrub Brush - Hardwood Block



Length	Trim Length	Fill Material	Order No.	Price
20"	2"	White Tampico	44017	

MASONRY BRUSH

Hardwood Block - Handle Attached



Block Size	Trim Length	Fill Material	Order No.	Price
6-1/2"	3-1/2"	White Tampico	44031	