

HIGH SPEED STEEL

**METAL SLITTING SAWS  
WITH STAGGERED SIDE TEETH**

SERIES 139 :



also available.  
See our website  
or inquire.

Dia.	Thickness	Hole Dia.	No. Of Teeth	Order No.	Price
2-1/2	1/16	1	32	315254	
2-1/2	3/32	1	32	315256	
2-1/2	1/8	1	32	315258	
3	1/16	1	32	9603047	
3	1/16	1-1/4	32	9603048	
3	5/64	1	32	9603057	
3	5/64	1-1/4	32	9603058	
3	3/32	1	32	9603067	
3	3/32	1-1/4	32	9603068	
3	7/64	1	32	9603077	
3	7/64	1-1/4	32	9603078	
3	1/8	1	32	9603087	
3	1/8	1-1/4	32	9603088	
3	9/64	1	32	9603097	
3	9/64	1-1/4	32	9603098	
3	5/32	1	32	9603107	
3	5/32	1-1/4	32	9603108	
3	11/64	1	32	9603117	
3	11/64	1-1/4	32	9603118	
3	3/16	1	32	9603127	
3	3/16	1-1/4	32	9603128	
3	7/32	1	32	9603147	
3	7/32	1-1/4	32	9603148	
3	1/4	1	32	9603167	
4	1/16	1	34	9604047	
4	1/16	1-1/4	34	9604048	
4	5/64	1	34	9604057	
4	5/64	1-1/4	34	9604058	
4	3/32	1	34	9604067	
4	3/32	1-1/4	34	9604068	
4	7/64	1	34	9604077	
4	7/64	1-1/4	34	9604078	
4	1/8	1	34	9604087	
4	1/8	1-1/4	34	9604088	
4	9/64	1	34	9604097	
4	9/64	1-1/4	34	9604098	
4	5/32	1	34	9604107	
4	5/32	1-1/4	34	9604108	
4	11/64	1	34	9604117	
4	11/64	1-1/4	34	9604118	
4	3/16	1	34	9604127	
4	3/16	1-1/4	34	9604128	
4	7/32	1	34	9604147	
4	7/32	1-1/4	34	9604148	
4	1/4	1	34	9604167	
4	1/4	1-1/4	34	9604168	

Dia.	Thickness	Hole Dia.	No. Of Teeth	Order No.	Price
5	3/32	1	38	9605067	
5	1/8	1	38	9605087	
5	1/8	1-1/4	38	9605088	
5	9/64	1	38	9605097	
5	9/64	1-1/4	38	9605098	
5	5/32	1	38	9605107	
5	5/32	1-1/4	38	9605108	
5	11/64	1	38	9605117	
5	11/64	1-1/4	38	9605118	
5	3/16	1	38	9605127	
5	3/16	1-1/4	38	9605128	
5	1/4	1	38	9605167	
5	1/4	1-1/4	38	9605168	
6	3/32	1-1/4	42	315606	
6	1/8	1	42	9606087	
6	1/8	1-1/4	42	9606088	
6	9/64	1	42	9606097	
6	9/64	1-1/4	42	9606098	
6	5/32	1	42	9606107	
6	5/32	1-1/4	42	9606108	
6	11/64	1	42	9606117	
6	11/64	1-1/4	42	9606118	
6	3/16	1	42	9606127	
6	3/16	1-1/4	42	9606128	
6	1/4	1	42	9606167	
6	1/4	1-1/4	42	9606168	
7	1/8	1	46	9607087	
7	1/8	1-1/4	46	9607088	
7	3/16	1	46	9607127	
7	3/16	1-1/4	46	9607128	
8	1/8	1	50	315808	
8	1/8	1-1/4	50	315809	
8	3/16	1	50	9608127	
8	3/16	1-1/4	50	9608128	
8	1/4	1-1/4	50	9608168	
10	1/8	1-1/4	50	315908	
10	1/8	1-1/2	50	315909	
10	3/16	1-1/4	60	9610128	
10	3/16	1-1/2	60	9610129	
10	1/4	1-1/4	60	9610168	
10	1/4	1-1/2	60	9610169	
12	1/8	1-1/4*	60	315958	
12	1/8	1-1/2*	60	315959	
12	3/16	1-1/4*	60	315962	
12	3/16	1-1/2*	60	315963	
12	1/4	1-1/2*	60	315966	
12	5/16	1-1/2*	60	315967	

\* Made in the USA

HIGH SPEED STEEL

**TAP AND DRILL SETS  
NATIONAL COARSE / 18 PC**

SERIES 639:



**National Coarse  
Hand Tap & Drill Set**

Tap Size	Drill Size
6-32	P #36
8-32	P #29
10-24	P #25
10-32	P #21
1/4" - 20	P #7
5/16" - 18	P F
3/8" - 16	P 5/16"
7/16" - 14	P U
1/2" - 13	p 27/64

Order No. 5790100  
Price:

**National Fine  
Hand Tap & Drill Set**

Tap Size	Drill Size
6-40	P #33
8-36	P #29
10-24	P #25
10-32	P #21
1/4" - 28	P #3
5/16" - 24	P I
3/8" - 24	P Q
7/16" - 20	P 25/64
1/2" - 20	p 29/64

Order No. 5790110  
Price:

**Metric  
Hand Tap & Drill Set**

Tap Size	Drill Size
M2.5 x 0.45	P 2.05
M3.0 x 0.50	P 2.50
M3.5 x 0.60	P 2.90
M4.0 x 0.70	P 3.30
M5.0 x 0.80	P 4.20
M6.0 x 1.00	P 5.00
M8.0 x 1.25	P 6.70
M10.0 x 1.50	P 8.50
M12.0 x 1.75	P 10.20

Order No. 5790200  
Price:

CUTTING TOOLS - SAWS

CUTTING TOOLS - TAPS

HIGH SPEED STEEL / GROUND THREAD

## STANDARD HAND TAPS

SERIES 1:

**MEGA**  
Superior Import



CUTTING TOOLS - TAPS & DIES

Size	Threads Per Inch	No. of Flutes	Ground Thread Limit	TAPER		PLUG		BOTTOMING		SETS	
				Order No.	Price	Order No.	Price	Order No.	Price	Order No.	Price
0	80	2	H1	0500800		0500801		0500802		0500803	
1	64	2	H1	0501640		0501641		0501642		0501643	
1	72	2	H1	0501720		0501721		0501722		0501723	
2	56	3	H2	0502560		0502561		0502562		0502563	
2	64	3	H2	0502640		0502641		0502642		0502643	
3	48	3	H2	0503480		0503481		0503482		0503483	
3	56	3	H2	0503560		0503561		0503562		0503563	
4	40	3	H2	0504400		0504401		0504402		0504403	
4	48	3	H2	0504480		0504481		0504482		0504483	
5	40	3	H2	0505400		0505401		0505402		0505403	
5	44	3	H2	0505440		0505441		0505442		0505443	
6	32	3	H3	0506320		0506321		0506322		0506323	
6	40	3	H2	0506400		0506401		0506402		0506403	
8	32	4	H3	0508320		0508321		0508322		0508323	
8	36	4	H2	0508360		0508361		0508362		0508363	
10	24	4	H3	0510240		0510241		0510242		0510243	
10	32	4	H3	0510320		0510321		0510322		0510323	
12	24	4	H3	0512240		0512241		0512242		0512243	
12	28	4	H3	0512280		0512281		0512282		0512283	
1/4	20	4	H3	0516200		0516201		0516202		0516203	
1/4	28	4	H3	0516280		0516281		0516282		0516283	
5/16	18	4	H3	0520180		0520181		0520182		0520183	
5/16	24	4	H3	0520240		0520241		0520242		0520243	
3/8	16	4	H3	0524160		0524161		0524162		0524163	
3/8	24	4	H3	0524240		0524241		0524242		0524243	
7/16	14	4	H3	0528140		0528141		0528142		0528143	
7/16	20	4	H3	0528200		0528201		0528202		0528203	
1/2	13	4	H3	0532130		0532131		0532132		0532133	
1/2	20	4	H3	0532200		0532201		0532202		0532203	
9/16	12	4	H3	0536120		0536121		0536122		0536123	
9/16	18	4	H3	0536180		0536181		0536182		0536183	
5/8	11	4	H3	0540110		0540111		0540112		0540113	
5/8	18	4	H3	0540180		0540181		0540182		0540183	
11/16	11	4	H3	0544110		0544111		0544112		0544113	
11/16	16	4	H3	0544160		0544161		0544162		0544163	
3/4	10	4	H3	0548100		0548101		0548102		0548103	
3/4	16	4	H3	0548160		0548161		0548162		0548163	
7/8	9	4	H4	0556090		0556091		0556092		0556093	
7/8	14	4	H4	0556140		0556141		0556142		0556143	
1	8	4	H4	0564080		0564081		0564082		0564083	
1	12	4	H4	0564120		0564121		0564122		0564123	
1	14	4	H4	0564140		0564141		0564142		0564143	
1-1/8	7	4	H4	0572070		0572071		0572072		0572073	
1-1/8	12	4	H4	0572120		0572121		0572122		0572123	
1-1/4	7	4	H4	0580070		0580071		0580072		0580073	
1-1/4	12	6	H4	0580120		0580121		0580122		0580123	
1-3/8	6	4	H4	0588060		0588061		0588062		0588063	
1-3/8	12	6	H4	0588120		0588121		0588122		0588123	
1-1/2	6	4	H4	0596060		0596061		0596062		0596063	
1-1/2	12	6	H4	0596120		0596121		0596122		0596123	

HIGH SPEED STEEL / GROUND THREAD

**STANDARD HAND TAPS**

SERIES 568 :



Size	Threads Per Inch	No of Flutes	Ground Thread Limit	TAPER		PLUG		BOTTOMING		SET	
				Order No.	Price	Order No.	Price	Order No.	Price	Order No.	Price
0	80	2	H1	0600800		0600801		0600802		0600803	
1	64	2	H1	0601640		0601641		0601642		0601643	
1	72	2	H1	0601720		0601721		0601722		0601723	
2	56	3	H2	0602560		0602561		0602562		0602563	
2	64	3	H2	0602640		0602641		0602642		0602643	
3	48	3	H2	0603480		0603481		0603482		0603483	
3	56	3	H2	0603560		0603561		0603562		0603563	
4	40	3	H2	0604400		0604401		0604402		0604403	
4	48	3	H2	0604480		0604481		0604482		0604483	
5	40	3	H2	0605400		0605401		0605402		0605403	
5	44	3	H2	0605440		0605441		0605442		0605443	
6	32	3	H3	0606320		0606321		0606322		0606323	
6	40	3	H2	0606400		0606401		0606402		0606403	
8	32	4	H3	0608320		0608321		0608322		0608323	
8	36	4	H2	0608360		0608361		0608362		0608363	
10	24	4	H3	0610240		0610241		0610245		0610246	
10	32	4	H3	0610320		0610321		0610325		0610326	
12	24	4	H3	0612240		0612241		0612242		0612243	
12	28	4	H3	0612280		0612281		0612282		0612283	
1/4	20	4	H3	0616200		0616201		0616202		0616203	
1/4	28	4	H3	0616280		0616281		0616282		0616283	
5/16	18	4	H3	0620180		0620181		0620182		0620183	
5/16	24	4	H3	0620240		0620241		0620242		0620243	
3/8	16	4	H3	0624160		0624161		0624162		0624163	
3/8	24	4	H3	0624240		0624241		0624242		0624243	
7/16	14	4	H3	0628140		0628141		0628142		0628143	
7/16	20	4	H3	0628200		0628201		0628202		0628203	
1/2	13	4	H3	0632130		0632131		0632132		0632133	
1/2	20	4	H3	0632200		0632201		0632202		0632203	
9/16	12	4	H3	0636120		0636121		0636122		0636123	
9/16	18	4	H3	0636180		0636181		0636182		0636183	
5/8	11	4	H3	0640110		0640111		0640112		0640113	
5/8	18	4	H3	0640180		0640181		0640182		0640183	
11/16	11	4	H3	0644110		0644111		0644112		0644113	
11/16	16	4	H3	0644160		0644161		0644162		0644163	
3/4	10	4	H3	0648100		0648101		0648102		0648103	
3/4	16	4	H3	0648160		0648161		0648162		0648163	
7/8	9	4	H4	0656090		0656091		0656092		0656093	
7/8	14	4	H4	0656140		0656141		0656142		0656143	
1	8	4	H4	0664080		0664081		0664082		0664083	
1	12	4	H4	0664120		0664121		0664122		0664123	
1	14	4	H4	0664140		0664141		0664142		0664143	
1-1/8	7	4	H4	0672070		0672071		0672072		0672073	
1-1/8	12	4	H4	0672120		0672121		0672122		0672123	
1-1/4	7	4	H4	0680070		0680071		0680072		0680073	
1-1/4	12	6	H4	0680120		0680121		0680122		0680123	
1-3/8	6	4	H4	0688060		0688061		0688062		0688063	
1-3/8	12	6	H4	0688120		0688121		0688122		0688123	
1-1/2	6	4	H4	0696060		0696061		0696062		0696063	
1-1/2	12	6	H4	0696120		0696121		0696122		0696123	

HIGH SPEED STEEL / GROUND THREAD

## SPECIAL HAND TAPS

SERIES 2:



Many other **SPECIALS** available.  
See our website or inquire.

**CUTTING TOOLS - TAPS & DIES**

Size	Threads Per Inch	Order No.			Price	Size	Threads Per Inch	Order No.			Price
		Taper	Plug	Bottoming				Taper	Plug	Bottoming	
6	36	8006360	8006361	8006362		5/8	36	8040360	8040361	8040362	
6	48	8006480	8006481	8006482		5/8	40	8040400	8040401	8040402	
7	36	8007360	8007361	8007362		11/16	12	8044120	8044121	8044122	
7	40	8007400	8007401	8007402		11/16	18	8044180	8044181	8044182	
7	48	8007480	8007481	8007482		11/16	20	8044200	8044201	8044202	
8	24	8008240	8008241	8008242		11/16	24	8044240	8044241	8044242	
8	40	8008400	8008401	8008402		11/16	27	8044270	8044271	8044272	
8	48	8008480	8008481	8008482		11/16	32	8044320	8044321	8044322	
10	28	8010280	8010281	8010282		3/4	12	8048120	8048121	8048122	
10	36	8010360	8010361	8010362		3/4	14	8048140	8048141	8048142	
10	40	8010400	8010401	8010402		3/4	18	8048180	8048181	8048182	
10	48	8010480	8010481	8010482		3/4	20	8048200	8048201	8048202	
12	32	8012320	8012321	8012322		3/4	24	8048240	8048241	8048242	
12	36	8012360	8012361	8012362		3/4	26	8048260	8048261	8048262	
12	40	8012400	8012401	8012402		3/4	27	8048270	8048271	8048272	
12	48	8012480	8012481	8012482		3/4	28	8048280	8048281	8048282	
5/32	32	8013320	8013321	8013322		3/4	32	8048320	8048321	8048322	
5/32	40	8013400	8013401	8013402		3/4	36	8048360	8048361	8048362	
7/32	32	8014320	8014321	8014322		13/16	10	8052100	8052101	8052102	
7/32	40	8014400	8014401	8014402		13/16	12	8052120	8052121	8052122	
1/4	24	8016240	8016241	8016242		13/16	14	8052140	8052141	8052142	
1/4	32	8016320	8016321	8016322		13/16	16	8052160	8052161	8052162	
1/4	36	8016360	8016361	8016362		13/16	18	8052180	8052181	8052182	
1/4	40	8016400	8016401	8016402		13/16	20	8052200	8052201	8052202	
9/32	32	8018320	8018321	8018322		13/16	24	8052240	8052241	8052242	
9/32	40	8018400	8018401	8018402		13/16	26	8052260	8052261	8052262	
5/16	20	8020200	8020201	8020212		13/16	28	8052280	8052281	8052282	
5/16	22	8020220	8020221	8020222		13/16	32	8052320	8052321	8052322	
5/16	32	8020320	8020321	8020324		13/16	36	8052360	8052361	8052362	
5/16	36	8020360	8020361	8020362		7/8	12	8056120	8056121	8056122	
5/16	40	8020400	8020401	8020402		7/8	16	8056160	8056161	8056162	
11/32	32	8022320	8022321	8022322		7/8	18	8056180	8056181	8056182	
3/8	14	8024140	8024141	8024142		7/8	20	8056200	8056201	8056202	
3/8	18	8024180	8024181	8024182		7/8	24	8056240	8056241	8056242	
3/8	20	8024200	8024201	8024202		7/8	27	8056270	8056271	8056272	
3/8	32	8024320	8024321	8024322		7/8	32	8056320	8056321	8056322	
7/16	24	8028240	8028241	8028242		7/8	40	8056400	8056401	8056402	
7/16	27	8028270	8028271	8028272		15/16	12	8060120	8060121	8060122	
15/32	32	8030320	8030321	8030322		15/16	16	8060160	8060161	8060162	
1/2	12	8032120	8032121	8032122		15/16	18	8060180	8060181	8060182	
1/2	14	8032140	8032141	8032142		15/16	20	8060200	8060201	8060202	
1/2	16	8032160	8032161	8032162		15/16	24	8060240	8060241	8060242	
1/2	18	8032180	8032181	8032182		15/16	27	8060270	8060271	8060272	
1/2	24	8032240	8032241	8032242		15/16	32	8060320	8060321	8060322	
1/2	28	8032280	8032281	8032282		1	10	8064100	8064101	8064102	
1/2	32	8032320	8032321	8032322		1	16	8064160	8064161	8064162	
9/16	16	8036160	8036161	8036162		1	18	8064180	8064181	8064182	
9/16	20	8036200	8036201	8036202		1	20	8064200	8064201	8064202	
9/16	24	8036240	8036241	8036242		1	24	8064240	8064241	8064242	
9/16	27	8036270	8036271	8036272		1	26	8064260	8064261	8064262	
9/16	28	8036280	8036281	8036282		1	27	8064270	8064271	8064272	
9/16	30	8036300	8036301	8036302		1	28	8064280	8064281	8064282	
9/16	32	8036320	8036321	8036322		1	32	8064320	8064321	8064322	
9/16	40	8036400	8036401	8036402		1	36	8064360	8064361	8064362	
5/8	12	8040120	8040121	8040122		1	40	8064400	8064401	8064402	
5/8	14	8040140	8040141	8040142		1-1/16	8	8068080	8068081	8068082	
5/8	16	8040160	8040161	8040162		1-1/16	10	8068100	8068101	8068102	
5/8	20	8040200	8040201	8040202		1-1/16	12	8068120	8068121	8068122	
5/8	24	8040240	8040241	8040242		1-1/16	14	8068140	8068141	8068142	
5/8	26	8040260	8040261	8040262		1-1/16	16	8068160	8068161	8068162	
5/8	27	8040270	8040271	8040272		1-1/16	18	8068180	8068181	8068182	
5/8	28	8040280	8040281	8040282		1-1/16	20	8068200	8068201	8068202	
5/8	32	8040320	8040321	8040322		1-1/16	24	8068240	8068241	8068242	

(Continued)

HIGH SPEED STEEL / GROUND THREAD

**SPECIAL HAND TAPS**

SERIES 2:

(Continued)



Size	Threads Per Inch	Order No.			Price	Size	Threads Per Inch	Order No.			Price
		Taper	Plug	Bottoming				Taper	Plug	Bottoming	
1-1/16	32	8068320	8068321	8068322		1-3/4	8	8148080	8148081	8148082	
1-1/8	8	8072080	8072081	8072082		1-3/4	10	8148100	8148101	8148102	
1-1/8	10	8072100	8072101	8072102		1-3/4	12	8148120	8148121	8148122	
1-1/8	16	8072160	8072161	8072162		1-3/4	14	8148140	8148141	8148142	
1-1/8	18	8072180	8072181	8072182		1-3/4	16	8148160	8148161	8148162	
1-1/8	20	8072200	8072201	8072202		1-3/4	18	8148180	8148181	8148182	
1-1/8	24	8072240	8072241	8072242		1-3/4	20	8148200	8148201	8148202	
1-1/8	27	8072270	8072271	8072272		1-3/4	24	8148240	8148241	8148242	
1-1/8	32	8072320	8072321	8072322		1-13/16	16	8152160	8152161	8152162	
1-3/16	8	8076080	8076081	8076082		1-7/8	5	8156050	8156051	8156052	
1-3/16	10	8076100	8076101	8076102		1-7/8	8	8156080	8156081	8156082	
1-3/16	12	8076120	8076121	8076122		1-7/8	10	8156100	8156101	8156102	
1-3/16	14	8076140	8076141	8076142		1-7/8	12	8156120	8156121	8156122	
1-3/16	16	8076160	8076161	8076162		1-7/8	16	8156160	8156161	8156162	
1-3/16	18	8076180	8076181	8076182		1-7/8	20	8156200	8156201	8156202	
1-3/16	20	8076200	8076201	8076202		1-15/16	12	8160120	8160121	8160122	
1-3/16	24	8076240	8076241	8076242		1-15/16	16	8160160	8160161	8160162	
1-3/16	32	8076320	8076321	8076322		1-15/16	18	8160180	8160181	8160182	
1-1/4	8	8080080	8080081	8080082		2	4-1/2	8200040	8200041	8200042	
1-1/4	10	8080100	8080101	8080102		2	6	8200060	8200061	8200062	
1-1/4	14	8080140	8080141	8080142		2	8	8200080	8200081	8200082	
1-1/4	16	8080160	8080161	8080162		2	10	8200100	8200101	8200102	
1-1/4	18	8080180	8080181	8080182		2	12	8200120	8200121	8200122	
1-1/4	20	8080200	8080201	8080202		2	14	8200140	8200141	8200142	
1-1/4	24	8080240	8080241	8080242		2	16	8200160	8200161	8200162	
1-1/4	26	8080260	8080261	8080262		2	18	8200180	8200181	8200182	
1-1/4	32	8080320	8080321	8080322		2	20	8200200	8200201	8200202	
1-5/16	8	8084080	8084081	8084082		2-1/16	12	8204120	8204121	8204122	
1-5/16	12	8084120	8084121	8084122		2-1/8	8	8208080	8208081	8208082	
1-5/16	14	8084140	8084141	8084142		2-1/8	12	8208120	8208121	8208122	
1-5/16	16	8084160	8084161	8084162		2-1/4	4-1/2	8216040	8216041	8216042	
1-5/16	18	8084180	8084181	8084182		2-1/4	8	8216080	8216081	8216082	
1-5/16	20	8084200	8084201	8084202		2-1/4	12	8216120	8216121	8216122	
1-3/8	8	8088080	8088081	8088082		2-1/4	14	8216140	8216141	8216142	
1-3/8	10	8088100	8088101	8088102		2-1/4	16	8216160	8216161	8216162	
1-3/8	14	8088140	8088141	8088142		2-1/4	18	8216180	8216181	8216182	
1-3/8	16	8088160	8088161	8088162		2-5/16	14	8220140	8220141	8220142	
1-3/8	18	8088180	8088181	8088182		2-5/16	16	8220160	8220161	8220162	
1-3/8	20	8088200	8088201	8088202		2-3/8	8	8224080	8224081	8224082	
1-3/8	24	8088240	8088241	8088242		2-3/8	12	8224120	8224121	8224122	
1-7/16	8	8092080	8092081	8092082		2-3/8	16	8224160	8224161	8224162	
1-7/16	12	8092120	8092121	8092122		2-1/2	4	8232040	8232041	8232042	
1-7/16	16	8092160	8092161	8092162		2-1/2	8	8232080	8232081	8232082	
1-7/16	18	8092180	8092181	8092182		2-1/2	12	8232120	8232121	8232122	
1-7/16	20	8092200	8092201	8092202		2-1/2	16	8232160	8232161	8232162	
1-1/2	8	8096080	8096081	8096082		2-5/8	8	8240080	8240081	8240082	
1-1/2	10	8096100	8096101	8096102		2-5/8	12	8240120	8240121	8240122	
1-1/2	14	8096140	8096141	8096142		2-5/8	16	8240160	8240161	8240162	
1-1/2	16	8096160	8096161	8096162		2-3/4	8	8248080	8248081	8248082	
1-1/2	18	8096180	8096181	8096182		2-3/4	12	8248120	8248121	8248122	
1-1/2	20	8096200	8096201	8096202		2-3/4	16	8248160	8248161	8248162	
1-1/2	24	8096240	8096241	8096242		2-7/8	8	8256080	8256081	8256082	
1-1/2	32	8096320	8096321	8096322		2-7/8	12	8256120	8256121	8256122	
1-9/16	12	8136120	8136121	8136122		3	4	8300040	8300041	8300042	
1-9/16	16	8136160	8136161	8136162		3	8	8300080	8300081	8300082	
1-9/16	18	8136180	8136181	8136182		3	12	8300120	8300121	8300122	
1-9/16	20	8136200	8136201	8136202		3	16	8300160	8300161	8300162	
1-5/8	5-1/2	8140050	8140051	8140052		3	18	8300180	8300181	8300182	
1-5/8	8	8140080	8140081	8140082		3 1/8	8	8308080	8308081	8308082	
1-5/8	10	8140100	8440101	8140102		3-1/8	12	8308120	8308121	8308122	
1-5/8	12	8140120	8140121	8140122		3-1/4	8	8316080	8316081	8316082	
1-5/8	16	8140160	8140161	8140162		3-1/4	12	8316120	8316121	8316122	
1-5/8	18	8140180	8140181	8140182		3-3/8	8	8324080	8324081	8324082	
1-5/8	20	8140200	8140201	8140202		3-3/8	12	8324120	8324121	8324122	
1-11/16	12	8144120	8144121	8144122		3-1/2	4	8332040	8332041	8332042	
1-11/16	16	8144160	8144161	8144162		3-1/2	8	8332080	8332081	8332082	
1-11/16	18	8144180	8144181	8144182		3-1/2	12	8332120	8332121	8332122	
1-11/16	20	8144200	8144201	8144202		4	8	8400080	8400081	8400082	
1-3/4	5	8148050	8148051	8148052		4	12	8400120	8400121	8400122	
1-3/4	6	8148060	8148061	8148062		4-1/2	12	8432120	8432121	8432122	

CUTTING TOOLS - TAPS & DIES

HIGH SPEED STEEL / GROUND THREAD

## METRIC HAND TAPS

SERIES 511:

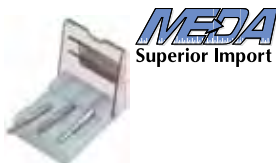

**CUTTING TOOLS - TAPS & DIES**

Size mm	Pitch mm	Order No.			Price	Order No. Set	Price Set
		Taper	Plug	Bott.			
1.4	.30	0140300	0140301	0140302		0140303	
1.5	.35	0150350	0150351	0150352		0150353	
1.6	.35	0160350	0160351	0160352		0160353	
1.7	.35	0170350	0170351	0170352		0170353	
1.8	.35	0180350	0180351	0180352		0180353	
2.0	.25	0200250	0200251	0200252		0200253	
2.0	.35	0200350	0200351	0200352		0200353	
2.0	.40	0200400	0200401	0200402		0200403	
2.0	.45	0200450	0200451	0200452		0200453	
2.2	.45	0220450	0220451	0220452		0220453	
2.3	.40	0230400	0230401	0230402		0230403	
2.5	.45	0250450	0250451	0250452		0250453	
2.6	.35	0260350	0260351	0260352		0260353	
2.6	.45	0260450	0260451	0260452		0260453	
3.0	.35	0300350	0300351	0300352		0300353	
3.0	.50	0300500	0300501	0300502		0300503	
3.0	.60	0300600	0300601	0300602		0300603	
3.5	.35	0350350	0350351	0350352		0350353	
3.5	.60	0350600	0350601	0350602		0350603	
4.0	.50	0400500	0400501	0400502		0400503	
4.0	.70	0400700	0400701	0400702		0400703	
4.0	.75	0400750	0400751	0400752		0400753	
4.5	.50	0450500	0450501	0450502		0450503	
4.5	.75	0450750	0450751	0450752		0450753	
5.0	.50	0500500	0500501	0500502		0500503	
5.0	.80	0500810	0500811	0500812		0500813	
5.0	.90	0500900	0500901	0500902		0500903	
5.0	1.00	0501000	0501001	0501002		0501003	
5.5	.90	0550900	0550901	0550902		0550903	
6.0	.50	0600500	0600501	0600502		0600503	
6.0	.75	0600750	0600751	0600752		0600753	
6.0	1.00	0601000	0601001	0601002		0601003	
6.3	1.00	0631000	0631001	0631002		0631003	
7.0	.75	0700750	0700751	0700752		0700753	
7.0	1.00	0701000	0701001	0701002		0701003	
8.0	.50	0800500	0800501	0800502		0800503	
8.0	.75	0800750	0800751	0800752		0800753	
8.0	1.00	0801000	0801001	0801002		0801003	
8.0	1.25	0801250	0801251	0801252		0801253	
8.0	1.50	0801500	0801501	0801502		0801503	
9.0	.50	0900500	0900501	0900502		0900503	
9.0	.75	0900750	0900751	0900752		0900753	
9.0	1.00	0901000	0901001	0901002		0901003	
9.0	1.25	0901250	0901251	0901252		0901253	
10.0	.50	1000500	1000501	1000502		1000503	
10.0	.75	1000750	1000751	1000752		1000753	
10.0	1.00	1001000	1001001	1001002		1001003	
10.0	1.25	1001250	1001251	1001252		1001253	
10.0	1.50	1001500	1001501	1001502		1001503	
11.0	.50	1100500	1100501	1100502		1100503	
11.0	.75	1100750	1100751	1100752		1100753	
11.0	1.00	1101000	1101001	1101002		1101003	
11.0	1.25	1101250	1101251	1101252		1101253	
11.0	1.50	1101500	1101501	1101502		1101503	
12.0	.75	1200750	1200751	1200752		1200753	
12.0	1.00	1201000	1201001	1201002		1201003	
12.0	1.25	1201250	1201251	1201252		1201253	
12.0	1.50	1201500	1201501	1201502		1201503	
12.0	1.75	1201750	1201751	1201752		1201753	
13.0	1.00	1301000	1301001	1301002		1301003	
13.0	1.50	1301500	1301501	1301502		1301503	
14.0	.75	1400751	1400752	1400753		1400754	
14.0	1.00	1401000	1401001	1401002		1401003	
14.0	1.25	1401250	1401251	1401252		1401254	
14.0	1.50	1401510	1401501	1401502		1401503	

HIGH SPEED STEEL / GROUND THREAD  
**+.005" OVERSIZE HAND TAPS**  
 PLUG STYLE  
 SERIES 7:



HIGH SPEED STEEL / GROUND THREAD  
**METRIC HAND TAPS**  
 SERIES 924:



.010" oversize taps available.  
 See our website or inquire.



Size	TPI	Order No.	Price	Size	TPI	Order No.	Price
4	40	1100440		7/16	14	1102814	
6	32	1100632		7/16	20	1102820	
6	40	473640		1/2	13	1103213	
8	32	1100832		1/2	20	1103220	
8	36	473736		9/16	12	474512	
10	24	1101024		9/16	18	474518	
10	32	1101032		5/8	11	1104011	
12	24	473924		5/8	18	1104018	
12	28	473928		3/4	10	1104810	
1/4	20	1101620		3/4	16	1104816	
1/4	28	1101628		7/8	9	1105609	
5/16	18	1102018		7/8	14	1105614	
5/16	24	1102024		1	8	1106408	
3/8	16	1102416		1	12	1106412	
3/8	24	1102424		1	14	1106414	

Size mm	Pitch mm	Pitch Dia. of Limit	No. of Fl.	Order No.			Price
				Taper	Plug	Bott	
1.6	.35	D3	2	-	328018	-	
2.0	.40	D3	3	328067	328075	328083	
2.5	.45	D3	3	-	328166	-	
3.0	.50	D3	3	328182*	328190*	328208*	
3.5	.60	D4	3	-	328257	-	
4.0	.70	D4	4	328273	328281*	328299*	
4.5	.75	D4	4	-	328349	-	
5.0	.80	D4	4	328364	328372*	328380*	
6.0	1.00	D5	4	328422	328430*	328448*	
6.3	1.00	D5	4	-	328463	-	
7.0	1.00	D5	4	328489	328497	328505	
8.0	1.25	D5	4	328547	328554*	328562*	
10.0	1.50	D6	4	328604	328612*	328620*	
12.0	1.75	D6	4	328661	328679*	328687*	
14.0	2.00	D7	4	328752	328760	328778	
16.0	2.00	D7	4	328810	328828	328836	
18.0	2.50	D7	4	328877	328885	328893	
20.0	2.50	D7	4	328935	328943	328950	
24.0	3.00	D8	4	329057	329065	329073	
30.0	3.50	D9	4	329172	329180	329198	
36.0	4.00	D9	4	329297	329305	329313	

\* Available in Gold (TIN) Coated.  
 See our website or inquire.

HIGH SPEED STEEL / GROUND THREAD  
**PULLEY HAND TAPS**  
 PLUG STYLE  
 SERIES 551:



MACHINE SCREW SIZES 6" OAL LENGTH

Size	TPI	Order No.	Price	Size	TPI	Order No.	Price
2	56	860002		5	48	860017	
2	64	860003		6	32	860020	
3	48	860006		6	40	860021	
3	56	860007		8	32	860024	
4	36	860010		8	36	860025	
4	40	860011		10	24	860028	
4	48	860012		10	32	860029	
5	40	860015		12	24	860032	
5	44	860016		12	28	860033	

FRACTIONAL SIZES

Size	TPI	6" OAL		8" OAL		10" OAL		12" OAL	
		Order No.	Price	Order No.	Price	Order No.	Price	Order No.	Price
1/4	20	5511620		5511621		860436		860636	
1/4	28	5511628		860237		860437		860637	
5/16	18	5512018		5512019		860440		860640	
5/16	24	5512024		860241		860441		860641	
3/8	16	5512416		5512417		860444		860644	
3/8	24	5512424		860245		860445		860645	
7/16	14	5512814		860248		860448		860648	
7/16	20	5512820		860249		860449		860649	
1/2	13	5513213		5513214		5513215		5513216	
1/2	20	5513220		860253		860453		860653	
5/8	11	5514011		5514012		5514013		5514014	
3/4	10	5514810		860264		5514811		5514812	
7/8	9					860468		860668	
7/8	14					860469		860669	

HIGH SPEED STEEL / GROUND THREAD  
**NUT TAPS**  
 SERIES 555:



Long chamfer / Undercut shank

Size	Threads Per Inch	Thread Length	Overall Length	Order No.	Price
1/4	20	1-5/8	5	5551620	
1/4	28	1-1/4	5	5551628	
5/16	18	1-13/16	5-1/2	5552018	
5/16	24	1-3/8	5-1/2	5552024	
3/8	16	2	6	5552416	
3/8	24	1-1/2	6	5552424	
7/16	14	2-3/8	6-1/2	5552814	
7/16	20	1-3/4	6-1/2	5552820	
1/2	13	2-1/2	7	5553213	
1/2	20	1-7/8	7	5553220	
9/16	12	2-3/4	7-1/2	5553612	
9/16	18	2	7-1/2	5553618	
5/8	11	3	8	5554011	
5/8	18	2-1/4	8	5554018	
11/16	11	2-1/5	8-1/4	468671	
11/16	16	2-1/2	8-1/4	468676	
3/4	10	3-1/4	9	5554810	
3/4	16	2-1/2	9	5554816	
7/8	9	3-5/8	10	5555609	
7/8	14	2 3/4	10	5555614	
1	8	4	11	5556408	
1	12	3-1/2	11	5556412	
1	14	3	11	5556414	



FOR  
**LONG SPIRAL POINTED TAPS**  
 SEE PAGE 170

HIGH SPEED STEEL / GROUND THREAD

## LEFT HAND TAPS

SERIES 3:

CUTTING TOOLS - TAPS & DIES

Many sizes available as **Spiral Pointed Gun Taps.** See our website or inquire.



Size	TPI	Flutes	GTL	Taper	Plug	Bott	Price	Set	Price
2	56	3	H2	494258	494256	494257		-	
2	64	3	H2	494266	494264	494265		-	
3	48	3	H2	494350	494348	494349		-	
3	56	3	H2	494358	494356	494357		-	
4	40	3	H2	9004399	9004401	9004402		9004403	
5	40	3	H2	9005400	9005401	9005402		9005403	
6	32	3	H3	9006320	9006321	9006322		9006323	
8	32	4	H3	9008320	9008321	9008322		9008323	
10	24	4	H3	9010240	9010241	9010242		9010243	
10	32	4	H3	9010320	9010321	9010322		9010323	
1/4	20	4	H3	9016200	9016201	9016202		9016203	
1/4	28	4	H3	9016280	9016281	9016282		9016283	
5/16	18	4	H3	9020180	9020181	9020182		9020183	
5/16	24	4	H3	9020240	9020241	9020242		9020243	
3/8	16	4	H3	9024160	9024161	9024162		9024163	
3/8	24	4	H3	9024240	9024241	9024242		9024243	
7/16	14	4	H3	9028140	9028141	9028142		9028143	
7/16	20	4	H3	9028200	9028201	9028202		9028203	
1/2	13	4	H3	9032130	9032131	9032132		9032133	
1/2	20	4	H3	9032200	9032201	9032202		9032203	
9/16	12	4	H3	9036120	9036121	9036122		9036123	
9/16	18	4	H3	9036180	9036181	9036182		9036183	
5/8	11	4	H3	9040110	9040111	9040112		9040113	
5/8	18	4	H3	9040180	9040181	9040182		9040183	
3/4	10	4	H3	9048100	9048101	9048102		9048103	
3/4	16	4	H3	9048160	9048161	9048162		9048163	
7/8	9	4	H4	9056090	9056091	9056092		9056093	
7/8	14	4	H4	9056140	9056141	9056142		9056143	
1	8	4	H4	9064080	9064081	9064082		9064083	
1	12	4	H4	9064120	9064121	9064122		9064123	
1	14	4	H4	9064140	9064141	9064142		9064143	
1-1/8	7	4	H4	9072070	9072071	9072072		9072073	
1-1/8	8	4	H4	9072080	9072081	9072082		9072083	
1-1/8	12	4	H4	9072120	9072121	9072122		9072123	
1-1/4	7	4	H4	9080070	9080071	9080072		9080073	
1-1/4	8	4	H4	9080080	9080081	9080082		9080083	
1-1/4	12	6	H4	9080120	9080121	9080122		9080123	
1-3/8	6	4	H4	9088060	9088061	9088062		9088063	
1-3/8	8	4	H4	9088080	9088081	9088082		9088083	
1-3/8	12	6	H4	9088120	9088121	9088122		9088123	
1-1/2	6	4	H4	9096060	9096061	9096062		9096063	
1-1/2	8	4	H4	9096080	9096081	9096082		9096083	
1-1/2	12	6	H4	9096120	9096121	9096122		9096123	
1-3/4	8	6	H4	9148080	9148081	9148082		9148083	

HIGH SPEED STEEL / GROUND THREAD

## LEFT HAND TAPS - METRIC SIZES

SERIES 3: PLUG STYLE



Size mm	Pitch mm	Order No.	Price
3.0	.50	3030050	
4.0	.70	3040070	
5.0	.80	3050080	
6.0	1.00	3360100	
7.0	1.00	3070100	
8.0	1.25	3080125	
10.0	1.50	3100150	
12.0	1.75	3120175	
14.0	2.00	3140200	
16.0	1.50	3360150	
16.0	2.00	3180200	
18.0	1.00	3180100	
18.0	1.50	3180150	

HIGH SPEED STEEL / GROUND THREAD

## HAND TAPS - LEFT HAND

SERIES 932:



FOUR FLUTE

Size	Threads Per Inc.	Ground Thread Limit	Order No.			Price	Size	Threads Per Inc.	Ground Thread Limit	Order No.			Price
			Taper	Plug	Bottom					Taper	Plug	Bottom	
10	32	H3	-	313102	313119		9/16	12	H3	317805	317813	317821	
1/4	20	H3	317508	317516	317524		9/16	18	H3	-	317847	-	
1/4	28	H3	-	317540	-		5/8	11	H3	317862	317870	317888	
5/16	18	H3	317565	317573	317581		5/8	18	H3	317896	317904	317912	
5/16	24	H3	317599	317607	317615		3/4	10	H3	317987	317995	318001	
3/8	16	H3	317623	317631	317649		3/4	16	H3	318019	318027	318035	
3/8	24	H3	317656	317664	317672		7/8	9	H4	-	318050	318068	
7/16	14	H3	317680	317698	317706		7/8	14	H4	318076	318084	318092	
7/16	20	H3	317714	317722	317730		1	8	H4	318100	318118	318126	
1/2	13	H3	317748	317755	317763		1	12	H4	318134	318142	318159	
1/2	20	H3	317771	317789	317797		1	14	H4	318167	318175	318183	



GROUND THREAD / PLUG STYLE  
**SPIRAL POINTED GUN TAPS**  
 SERIES 6: HIGH SPEED STEEL  
 SERIES 978: COBALT STEEL



HIGH SPEED STEEL / GROUND THREAD  
**SPIRAL POINTED GUN TAPS**  
 PLUG STYLE  
 SERIES 549:



Size	TPI	No. of Flutes	GH Limit	High Speed Steel		Cobalt Steel	
				Order No.	Price	Order No.	Price
0	80	2	H1	1050080	-	-	-
1	64	2	H1	1050164	-	-	-
1	72	2	H1	1050172	-	-	-
2	56	2	H2	1050256	-	9783210	-
2	64	2	H2	1050264	-	9783211	-
3	48	2	H2	1050348	-	9783212	-
3	56	2	H2	1050356	-	9783213	-
4	40	2	H2	1050440	-	9783214	-
4	48	2	H2	1050448	-	9783215	-
5	40	2	H2	1050540	-	9783216	-
5	44	2	H2	1050544	-	9783217	-
6	32	2	H3	1050632	-	9783218	-
6	40	2	H2	1050640	-	9783219	-
8	32	2	H3	1050832	-	9783220	-
8	36	2	H2	1050836	-	9783221	-
10	24	2	H3	1051024	-	9783222	-
10	32	2	H3	1051032	-	9783223	-
12	24	2	H3	1051224	-	9783224	-
12	28	2	H3	1051228	-	9783225	-
1/4	20	2	H3	1051620	-	9783226	-
1/4	28	2	H3	1051628	-	9783227	-
5/16	18	2	H3	1052018	-	9783228	-
5/16	24	2	H3	1052024	-	9783229	-
3/8	16	3	H3	1052416	-	9783229	-
3/8	24	3	H3	1052424	-	9783230	-
7/16	14	3	H3	1052814	-	9783231	-
7/16	20	3	H3	1052820	-	9783232	-
1/2	13	3	H3	1053213	-	9783233	-
1/2	20	3	H3	1053220	-	9783235	-
9/16	12	3	H3	1053612	-	-	-
9/16	18	3	H3	1053618	-	-	-
5/8	11	3	H3	1054011	-	9783236	-
5/8	18	3	H3	1054018	-	-	-
3/4	10	3	H3	1054810	-	9783237	-
3/4	16	3	H3	1054816	-	-	-
7/8	9	3	H4	1055609	-	-	-
7/8	14	3	H4	1055614	-	-	-
1	8	3	H4	1056408	-	-	-
1	12	3	H4	1056412	-	-	-
1	14	3	H4	1056414	-	-	-

Size	T.P.I	No. of Flutes	Ground Thread Limit*	USA	
				Order No.	Price
0	80	2	H1	1060080	-
1	64	2	H1	1060164	-
1	72	2	H1	1060172	-
2	56	2	H2	1060256	-
2	64	2	H2	1060264	-
3	48	2	H2	1060348	-
3	56	2	H2	1060356	-
4	40	2	H2	1060440	-
4	48	2	H2	1060448	-
5	40	2	H2	1060540	-
5	44	2	H2	1060544	-
6	32	2	H3	1060632	-
6	40	2	H2	1060640	-
8	32	2	H3	1060832	-
8	36	2	H2	1060836	-
10	24	2	H3	1061024	-
10	32	2	H3	1061031	-
12	24	2	H3	1061224	-
12	28	2	H3	1061228	-
1/4	20	2	H3	1061620	-
1/4	28	2	H3	1061628	-
5/16	18	2	H3	1062018	-
5/16	24	2	H3	1062024	-
3/8	16	3	H3	1062416	-
3/8	24	3	H3	1062424	-
7/16	14	3	H3	1062814	-
7/16	20	3	H3	1062820	-
1/2	13	3	H3	1063213	-
1/2	20	3	H3	1063220	-
9/16	12	3	H3	1063612	-
9/16	18	3	H3	1063618	-
5/8	11	3	H3	1064011	-
5/8	18	3	H3	1064018	-
3/4	10	3	H3	1064810	-
3/4	16	3	H3	1064816	-
7/8	9	3	H4	1065609	-
7/8	14	3	H4	1065614	-
1	8	3	H4	1066408	-
1	12	3	H4	1066412	-
1	14	3	H4	1066414	-

SOLID CARBIDE / GROUND THREAD  
**SPIRAL POINTED GUN TAPS**  
 PLUG STYLE  
 SERIES 819:



HIGH SPEED STEEL / SPECIAL THREAD  
**SPIRAL POINTED GUN TAPS**  
 PLUG STYLE  
 SERIES 820:



Size	T.P.I	No. of Flutes	Ground Threads Limit	Order No.	Price
4	40	2	H2	8190440	-
6	32	2	H3	8190632	-
8	32	2	H3	8190832	-
10	24	2	H3	8191024	-
10	32	2	H3	8191032	-
1/4	20	2	H3	8191620	-
5/16	18	2	H3	8192018	-
3/8	16	2	H3	8192416	-

Size	T.P.I	No. of Flutes	Ground Thread Limit	Order No.	Price
6	48	2	H3	8200648	-
8	40	2	H3	8200840	-
10	40	2	H3	8201040	-
12	32	2	H3	8201232	-
1/4	24	2	H3	8201624	-
1/4	32	2	H3	8201632	-
1/4	40	2	H3	8201640	-
5/16	32	3	H3	8202032	-
3/8	32	3	H3	8202432	-
1/2	24	3	H3	8203224	-
1/2	28	3	H3	8203228	-

CUTTING TOOLS - TAPS & DIES

HIGH SPEED STEEL / GROUND THREAD  
**SPIRAL POINTED GUN TAPS**

PLUG STYLE - GOLD (TIN) COATED

SERIES 817 :



Size	T.P.I	No.of Flutes	Ground Threads Limit	Order No.	Price	Size	T.P.I	No.of Flutes	Ground Threads Limit	Order No.	Price
0	80	2	H1	8170080		1/4	20	2	H3	8171620	
1	64	2	H1	8170164		1/4	28	2	H3	8171628	
1	72	2	H1	8170172		5/16	18	2	H3	8172018	
2	56	2	H2	8170256		5/16	24	2	H3	8172024	
2	64	2	H2	8170264		3/8	16	3	H3	8172416	
3	48	2	H2	8170348		3/8	24	3	H3	8172424	
3	56	2	H2	8170356		7/16	14	3	H3	8172814	
4	40	2	H2	8170440		7/16	20	3	H3	8172820	
4	48	2	H2	8170448		1/2	13	3	H3	8173213	
5	40	2	H2	8170540		1/2	20	3	H3	8173220	
5	44	2	H2	8170544		5/8	11	3	H3	8174011	
6	32	2	H3	8170632		5/8	18	3	H3	8174018	
6	40	2	H2	8170640		3/4	10	3	H3	8174810	
8	32	2	H3	8170832		3/4	16	3	H3	8174816	
8	36	2	H2	8170836		7/8	9	3	H4	8175609	
10	24	2	H3	8171024		7/8	14	3	H4	8175614	
10	32	2	H3	8171032		1	8	3	H4	8176408	
12	24	2	H3	8171224		1	12	3	H4	8176412	
12	28	2	H3	8171228		1	14	3	H4	8176414	

CUTTING TOOLS - TAPS & DIES

HIGH SPEED / GROUND THREAD  
**SPIRAL POINTED GUN TAPS**

BOTTOMING STYLE

SERIES 919:



HIGH SPEED STEEL / GROUND THREAD  
**SPIRAL POINTED GUN TAPS**

PLUG STYLE - GOLD (TIN) COATED

SERIES 919:



Size	T.P.I.	No. of Flutes	Ground Thread Limit*	Order No.	Price
0	80	2	H1	356019	
2	56	2	H2	356159	
3	48	2	H2	356233	
4	40	2	H2	356332	
5	40	2	H2	356415	
6	32	2	H3	356514	
6	40	2	H2	356555	
8	32	2	H3	356634	
10	24	2	H3	356712	
10	32	2	H3	356779	
12	24	2	H3	894487	
1/4	20	2	H3	357058	
1/4	28	2	H3	357173	
5/16	18	2	H3	357298	
5/16	24	2	H3	357413	

Size	T.P.I	No.of Flutes	Ground Thread Limit	Order No.	Price
0	80	2	H1	356023	
1	72	2	H1	356106	
2	56	2	H2	356148	
2	64	2	H2	356189	
3	48	2	H2	356221	
3	56	2	H2	356262	
4	40	2	H2	356320	
4	48	2	H2	356361	
5	40	2	H2	356403	
5	44	2	H2	356402	
6	32	2	H3	356502	
6	40	2	H2	356544	
8	32	2	H3	356602	
10	24	2	H3	356703	
10	32	2	H3	356767	
12	24	2	H3	356809	
12	28	2	H3	356841	
1/4	20	2	H3	357047	
1/4	28	2	H3	357161	
5/16	18	2	H3	357286	
5/16	24	2	H3	357401	
3/8	16	3	H3	357526	
3/8	24	3	H3	357609	
7/16	14	3	H3	357682	
7/16	20	3	H3	357765	
1/2	13	3	H3	357823	
1/2	20	3	H3	357864	
5/8	11	3	H3	357922	
3/4	10	3	H3	357963	
7/8	9	3	H4	9195609	
7/8	14	3	H4	9195614	
1	8	3	H4	9196408	
1	12	3	H4	9196412	
1	14	3	H4	9196414	

**Quality Cutting Tools**



**The Choice Is Yours!!!**

HIGH SPEED STEEL / GROUND THREAD

**METRIC SPIRAL POINTED GUN TAPS**

SERIES 556:



HIGH SPEED STEEL / GROUND THREAD

**METRIC SPIRAL POINTED GUN TAPS**

SERIE 824:



Size mm	Pitch mm	Order No.	Price	Size mm	Pitch mm	Order No.	Price
1.6	.35	5561635		10.0	1.00	5561010	
1.8	.35	5561835		10.0	1.25	5561012	
2.0	.40	5562040		10.0	1.50	5561015	
2.2	.45	5562245		12.0	1.00	5561210	
2.5	.45	5562545		12.0	1.25	5561212	
3.0	.50	5563050		12.0	1.50	5561215	
3.5	.60	5563560		12.0	1.75	5561217	
4.0	.70	5564070		14.0	1.00	5561410	
4.5	.75	5564575		14.0	1.25	5561412	
5.0	.50	5565050		14.0	1.50	5561415	
5.0	.80	5565080		14.0	2.00	5561420	
5.0	.90	5565090		16.0	1.00	5561610	
6.0	.50	5566050		16.0	1.50	5561615	
6.0	.75	5566075		16.0	2.00	5561620	
6.0	1.00	5566010		18.0	1.00	5561810	
6.3	1.00	5566310		18.0	1.50	5561815	
7.0	1.00	5567010		18.0	2.00	5561820	
8.0	.75	5568075		18.0	2.50	5561825	
8.0	1.00	5568010		20.0	1.00	5562010	
8.0	1.25	5568012		20.0	1.50	5562015	
9.0	1.0	5569010		20.0	2.50	5562025	

Size mm	Pitch mm	Pitch Dia. Limit	No. of Flutes	Order No.	Price
1.6	.35	D3	2	360755	
2.0	.40	D3	2	360771	
2.5	.45	D3	2	360797	
3.0	.50	D3	2	360805	
3.5	.60	D4	2	360821*	
4.0	.70	D4	2	360839*	
4.5	.75	D4	2	360854	
5.0	.80	D4	2	360862*	
6.0	1.00	D5	2	360888*	
6.3	1.00	D5	2	360896	
7.0	1.00	D5	2	360904	
8.0	1.25	D5	2	360920	
10.0	1.50	D6	3	360946*	
12.0	1.75	D6	3	360961*	
14.0	2.00	D7	3	360995	
16.0	2.00	D7	3	361019	
18.0	2.50	D7	3	361035	
20.0	2.50	D7	3	361050	

\* Available Gold (TIN) Coated. See our website or inquire.

HIGH SPEED STEEL / GROUND THREAD

**+.005" OVERSIZE SPIRAL POINTED GUN TAPS**

PLUG STYLE

SERIES 8:



HIGH SPEED STEEL / GROUND THREAD

**LEFT HAND SPIRAL POINTED GUN TAPS**

SERIES 830:



Size	Threads Per Inch	Order No.	Price
4	40	1150440	
5	40	1150540	
6	32	1150632	
6	40	475640	
8	32	1150832	
8	36	475736	
10	24	1151024	
10	32	1151032	
12	24	475924	
12	28	475928	
1/4	20	1151620	
1/4	28	1151628	
5/16	18	1152018	
5/16	24	1152024	
3/8	16	1152416	
3/8	24	1152424	
7/16	14	1152814	
7/16	20	1152820	
1/2	13	1153213	
1/2	20	1153220	
5/8	11	1154011	
5/8	18	1154018	
3/4	10	1154810	
3/4	16	1154816	
7/8	9	1155609	
7/8	14	1155614	
1	8	1156408	
1	12	1156412	
1	14	1156414	



Sizes 0 - 80 thru 4 - 40 available. See our website or inquire.

Size	Threads Per Inch	Order No.	Price
4	40	8300440	
5	40	8300540	
6	32	8300632	
8	32	8300832	
10	24	8301024	
10	32	8301032	
1/4	20	8301620	
1/4	28	8301628	
5/16	18	8302018	
5/16	24	8302024	
3/8	16	8302416	
3/8	24	8302424	
1/2	13	8303213	
1/2	20	8303220	
5/8	11	8304011	
5/8	18	8304018	
3/4	10	8304810	
3/4	16	8304816	
7/8	9	8305609	
7/8	14	8305614	
1	8	8306408	
1	12	8306412	
1	14	8306414	

HIGH SPEED STEEL / GROUND THREAD  
**ACME TAPS - TANDEM STYLE**  
 SERIES 554:



HIGH SPEED STEEL / GROUND THREAD  
**SPIRAL POINTED GUN PULLEY TAPS**  
 SERIES 552:



Size	TPI	Thread Length	Overall Length	Order No.	Price
1/2	10	2-9/16	5	5543210	
5/8	8	3-3/16	6-1/4	5544008	
3/4	6	4-5/16	7-15/16	5544806	
7/8	6	4-3/8	8-5/8	5545606	
1	5	5-1/4	10-1/8	5546405	
1-1/8	5	5-1/4	10-3/4	5547205	
1-1/4	5	5-1/4	11-1/8	5548005	
1-3/8	4	5-7/8	12-1/4	5548804	
1-1/2	4	5-7/8	12-5/8	5549604	



Size	Threads Per Inch	No. of Flutes	Order No.	Price
6	32	2	860120	
8	32	2	860124	
10	24	2	5521024	
10	32	2	5521032	
1/4	20	2	5521620	
1/4	28	2	5521628	
5/16	18	2	5522018	
5/16	24	2	5522024	
3/8	16	3	5522416	
3/8	24	3	5522424	
1/2	13	3	5523213	
1/2	20	3	5523220	
5/8	11	3	860160	
3/4	10	3	5524810	

Many other sizes and 8", 10", 12" are available. See our website or inquire.

HIGH SPEED STEEL / GROUND THREAD  
**EXTENSION SPIRAL POINT TAPS**



SERIES 922:  
 PLUG STYLE / OAL: 6" / GROUND THREAD LIMIT: GH3



Size	Threads Per Inch	No. of Flutes	Order No.	Price
6	32	2	918930	
8	32	2	918932	
10	24	2	918934	
10	32	2	918935	
1/4	20	2	918936	
1/4	28	2	918937	
5/16	18	2	918938	
5/16	24	2	918939	
3/8	16	3	918940	
3/8	24	3	918941	

HIGH SPEED STEEL / PLUG STYLE  
**LONG SPIRAL POINTED GUN TAPS**



SERIES 553:  
 OVERALL LENGTH: 6" GROUND THREAD LIMIT: GH3

Long undercut shanks provide deeper reach and smoother chip flow.

Size	Threads Per Inch	Order No.	Price
4*	40	5530440	
6	32	5530632	
8	32	5530832	
10	24	5531024	
10	32	5531032	
1/4	20	5531620	
1/4	28	5531628	
5/16	18	5532018	
5/16	24	5532024	
3/8	16	5532416	
3/8	24	5532423	
7/16	14	5532814	
7/16	20	5532820	
1/2	13	5533213	
1/2	20	5533220	



\* Overall Length: 4", Ground Thread Limit: GH2

HIGH SPEED STEEL / GROUND THREAD  
**CNC TAPS**  
 SERIES 872:



**CNC HEAVY DUTY SPIRAL POINT TAPS**

CNC Heavy Duty Spiral Point taps are designed to tap difficult to machine hard materials such as heat-treated steels, tool steels, and some hard exotic materials up to 35 Rc. Spiral Point CNC Heavy Duty Taps, which drive the chips ahead of the tool, are recommended for through holes or blind holes with sufficient chip clearance. For blind holes, CNC Heavy Duty Spiral Fluted Taps are recommended. CNC taps are manufactured with closely controlled dimensions for fast, repeatable tool changes on CNC equipment.

Size	Threads Per Inch	Overall Length	Thread Length	CNC H/D SpPt Plug	
				Order No.	Price
6	32	2	3/8	282108	
8	32	2-1/8	3/8	282157	
10	24	2-3/8	1/2	282207	
10	32	2-3/8	1/2	282256	
1/4	20	2-1/2	5/8	282306	
1/4	28	2-1/2	5/8	282405	
5/16	18	2-23/32	11/16	282454	
5/16	24	2-23/32	11/16	282504	
3/8	16	2-15/16	3/4	282553	
3/8	24	2-15/16	3/4	282652	
7/16	14	3-5/32	7/8	282702	
7/16	20	3-5/32	7/8	282751	
1/2	13	3-3/8	15/16	282801	
1/2	20	3-3/8	15/16	282901	
5/8	11	3-13/16	1-1/8	282959	

**TAP EXTENSIONS**



SERIES 410:



For use with a tap wrench to permit tapping in hard to get at places.

Overall Length	Capacity		Order No.	Price
	Hand Taps	Machine Screw Taps		
7	1/16-1/4	0-14	4100012	
10-3/4	1/4-1/2	-	4100023	



SERIES 872:

**CNC TAPS**

SERIES 872:



GROUND THREAD - GOLD (TiN) COATED

**Coating:** Titanium Nitride (TiN) (bright gold color)

**Recommended Applications:** For ferrous, nonmetallic and some nonferrous materials. Extreme hardness and low coefficient of friction increase tool life, improve thread finish and often allow higher tapping speeds for increased productivity. Use in steel, cast iron, stainless steel, high-temperature alloys, plastics, rubber, and most non-ferrous castings.

**Precautions:** Avoid in titanium and titanium alloys and most wrought nonferrous materials due to tendency to gall.

CNC H/D SpPt. Plug : HSS/ Ground Thread Heavy Duty Spiral Point Taps

CNC AERO SpPt. Plug : HSS / Ground Thread AERO Spiral Point Taps

CNC H/D SpFl. Plug / Bott : HSS / Ground Thread Spiral Fluted Taps



SPIRAL POINT



SPIRAL FLUTED

**CNC HEAVY DUTY SPIRAL POINT TAPS**

TiN Coated CNC Heavy Duty Spiral Point taps are designed to tap difficult to machine hard materials such as heat-treated steels, tool steels, and some hard exotic materials up to 35 Rc. Spiral Point CNC Heavy Duty Taps, which drive the chips ahead of the tool, are recommended for through holes or blind holes with sufficient chip clearance. For blind holes, CNC Heavy Duty Spiral Fluted Taps are recommended. CNC taps are manufactured with closely controlled dimensions for fast, repeatable tool changes on CNC equipment.

**CNC AERO SPIRAL POINT TAPS**

TiN Coated CNC AERO Spiral Point Taps were developed to tap heat resisting stainless steel alloys, for example 17-4PH, A286 and other soft nickel based exotic materials such as Hastelloy, Inconel, Waspoly, and Incoloy. The unique spiral point geometry is designed to freely tap these difficult to machine Aerospace materials with minimal contact between work material and tool. With CNC equipment in mind, tap dimensions are closely controlled for fast, repeatable tap changes. CNC AERO taps are recommended for exotic materials 275 BHN or less. For harder materials, TiN Coated CNC Heavy Duty Taps are recommended.

**CNC SPIRAL FLUTED TAPS**

TiN Coated CNC Heavy Duty Spiral Fluted taps are designed to tap blind holes in heat-treated steels, tool steels, and some hard exotic materials up to 35 Rc. For through holes, CNC Heavy Duty Spiral Point Taps are recommended. CNC taps are manufactured with closely controlled dimensions for fast, repeatable tool changes on CNC equipment.

Size	Threads Per Inch	No. of Flutes	Ground Thread Limit ‡	Overall Length	Thread Length
6	32	3	H3	2	3/8
8	32	3	H3	2-1/8	3/8
10	24	3	H3	2-3/8	1/2
10	32	3	H3	2-3/8	1/2
1/4	20	3	H3	2-1/2	5/8
1/4	28	3	H3	2-1/2	5/8
5/16	18	3	H3	2-23/32	11/16
5/16	24	3	H3	2-23/32	11/16
3/8	16	3	H3	2-15/16	3/4
3/8	24	3	H3	2-15/16	3/4
7/16	14	3	H3	3-5/32	7/8
7/16	20	3	H3	3-5/32	7/8
1/2	13	3	H3	3-3/8	15/16
1/2	20	3	H3	3-3/8	15/16
5/8	11	3*	H3	3-13/16	1-1/8
3/4	10	3	H5	4-1/4	1-1/4

\* CNC HD SpFl; 4 Flute

‡ Other "Pitch Diameter Limits" available. See our website or inquire.

Size	Threads Per Inch	CNC H/D SpPt Plug		CNC AERO SpPt Plug		CNC H/D SpFl Plug / Bott		
		Order No.	Price	Order No. Plug	Price	Order No. Plug	Order No. Bott	Price
6	32	280108		285057		281957	282005	
8	32	280157		285107		282054	282104	
10	24	280207		285156		282062	282120	
10	32	280256		285206		282153	282203	
1/4	20	280306		285255		282252	282302	
1/4	28	280405		285354		282351	282401	
5/16	18	280454		285404		282450	282501	
5/16	24	280504		285453		282468	282526	
3/8	16	280553		285503		282559	282609	
3/8	24	280652		285602		282567	282625	
7/16	14	280702		285651		282658	282708	
7/16	20	280751		285701		-	-	
1/2	13	280801		285750		282757	282807	
1/2	20	280901		285859		282765	282823	
5/8	11	280959		282856		282856	282906	
3/4	10	281056		-		-	-	



## CNC FORMING TAPS HIGH SPEED STEEL - GROUND THREAD SERIES 872 :



The STAR USA CNC Forming Tap is a new design expanding the use of forming taps further into harder and less ductile materials which up to now have been successfully tapped with other existing types of forming taps. The design of the CNC Forming Tap makes it less sensitive to undesirable hole conditions such as size variation, out-of-roundness, and excessive taper that often cause other forming taps to fail or break. However, in the case of holes that are small, or excessively tapered, the CNC Forming Tap may generate some fine chips.

STAR USA CNC Forming Taps are designed to form threads by material displacement. This process results in numerous tapping advantages: greater tap strength, especially in smaller tap sizes; potentially greater fastener strength; and elimination of chip disposal. CNC Forming Taps have been designed with straight lobes and oil grooves (#5, M3 and larger). They can be used to advantage in soft, ductile materials (25Rc or less). They are manufactured with closely controlled dimensions for fast, repeatable tool changes and therefore are well suited for use on CNC equipment.



Inch Sizes

Size	Threads Per Inch	Ground Thread Limit	Overall Length	Thread Length	Order No.		Price
					CNC Plug	CNC Bottoming	
4	40	H3	1-7/8	5/16	289004	289012	
4	40	H5	1-7/8	5/16	289020	289038	
4	48	H3	1-7/8	5/16	289046	289053	
5	40	H3	1-15/16	3/8	289087	289095	
5	40	H5	1-15/16	3/8	-	289111	
6	32	H3	2	3/8	289202	289210	
6	32	H5	2	3/8	289228	289236	
6	32	H10	2	3/8	289244	289251	
6	40	H3	2	3/8	289160	289178	
6	40	H5	2	3/8	289186	289194	
8	32	H3	2-1/8	3/8	289269	289277	
8	32	H5	2-1/8	3/8	289285	289293	
8	32	H10	2-1/8	3/8	289301	289319	
8	36	H3	2-1/8	3/8	-	289335	
8	36	H5	2-1/8	3/8	289343	289350	
10	24	H4	2-3/8	1/2	289368	289376	
10	24	H6	2-3/8	1/2	289384	289392	
10	32	H4	2-3/8	1/2	289426	289434	
10	32	H6	2-3/8	1/2	289442	289459	
10	32	H10	2-3/8	1/2	289467	-	
1/4	20	H4	2-1/2	5/8	289525	289533	
1/4	20	H6	2-1/2	5/8	289541	289558	
1/4	20	H10	2-1/2	5/8	289566	-	
1/4	28	H4	2-1/2	5/8	289582	289590	
1/4	28	H6	2-1/2	5/8	289608	289616	
5/16	18	H5	2-23/32	11/16	289640	289657	
5/16	18	H7	2-23/32	11/16	289665	289673	
5/16	18	H10	2-23/32	11/16	-	289699	
5/16	24	H5	2-23/32	11/16	289707	289715	
5/16	24	H7	2-23/32	11/16	289723	289731	
3/8	16	H5	2-15/16	3/4	289764	289772	
3/8	16	H7	2-15/16	3/4	289780	289798	
3/8	24	H5	2-15/16	3/4	289822	289830	
3/8	24	H7	2-15/16	3/4	-	289855	
7/16	14	H5	3-5/32	7/8	289889	289897	
7/16	14	H8	3-5/32	7/8	-	289913	
7/16	20	H5	3-5/32	7/8	289921	289939	
7/16	20	H8	3-5/32	7/8	-	289954	
1/2	13	H5	3-3/8	15/16	289962	289970	
1/2	13	H8	3-3/8	15/16	289988	289996	
1/2	20	H5	3-3/8	15/16	290002	290010	

(Continued)



HIGH SPEED STEEL / GROUND THREAD

**CNC FORMING TAPS**

SERIES 872:

(Continued)



Metric Sizes

Size	Threads Per Inch	Ground Thread Limit	Overall Length	Thread Length	Order No.		Price
					CNC Plug	CNC Bottoming	
M3	0.5	D5	1-15/16	3/8	291001	291018	
M4	0.7	D6	2-1/8	3/8	291083	291091	
M5	0.8	D7	2-3/8	1/2	291125	291133	
M6	1.0	D8	2-1/2	5/8	291166	291174	
M8	1.25	D9	2-23/32	11/16	291240	291257	
M10	1.5	D10	2-15/16	3/4	291176	291178	
M12	1.75	D11	3-3/8	15/16	291179	291181	

HIGH SPEED STEEL / GROUND THREAD

**CNC FORMING TAPS - GOLD (TIN) COATED**

STAR USA TiN COATED CNC Forming Taps are designed to form threads by material displacement. This process results in numerous tapping advantages: greater tap strength, especially in smaller tap sizes; potentially greater fastener strength; and elimination of chip disposal. STAR USA TiN COATED CNC Forming Taps have been designed with straight lobes and oil grooves (#8, M4 and larger) to take maximum advantage of TiN coating. They can be used to advantage in soft, ductile materials (25Rc or less). They are manufactured with closely controlled dimensions for fast, repeatable tool changes and therefore are well suited for use on CNC equipment.



Inch Sizes

Size	Threads Per Inch	Ground Thread Limit	Overall Length	Thread Length	Order No.		Price
					CNC Plug	CNC Bottoming	
6	32	H3	2	3/8	287004	287053	
6	32	H5	2	3/8	287103	287152	
8	32	H3	2-1/8	3/8	287202	287251	
8	32	H5	2-1/8	3/8	287301	287350	
10	24	H4	2-3/8	1/2	287400	287459	
10	24	H6	2-3/8	1/2	287509	287558	
10	32	H6	2-3/8	1/2	287608	287657	
1/4	20	H4	2-1/2	5/8	287665	287634	
1/4	20	H6	2-1/2	5/8	287707	287756	
1/4	28	H6	2-1/2	5/8	287806	287855	
5/16	18	H7	2-23/32	11/16	287905	287954	
5/16	24	H7	2-23/32	11/16	288002	288051	
3/8	16	H7	2-15/16	3/4	288101	288150	
3/8	24	H7	2-15/16	3/4	288200	288259	
7/16	14	H8	3-5/32	7/8	288309	288358	
1/2	13	H8	3-3/8	15/16	288408	288457	



Metric Sizes

Size	Threads Per Inch	Ground Thread Limit	Overall Length	Thread Length	Order No.		Price
					CNC Plug	CNC Bottom	
M3	0.5	D5	1-15/16	3/8	291006	291014	
M4	0.7	D6	2-1/8	3/8	291089	291097	
M5	0.8	D7	2-3/8	1/2	291123	291139	
M6	1.0	D8	2-1/2	5/8	291162	291170	
M8	1.25	D9	2-23/32	11/16	291246	291253	
M10	1.5	D10	2-15/16	3/4	291287	291295	
M12	1.75	D11	3-3/8	15/16	291180	291182	

## HIGH SPEED STEEL / GROUND THREAD 48° FAST SPIRAL FLUTED TAPS



## HIGH SPEED STEEL / GROUND THREAD 30° SPIRAL FLUTED TAPS



SERIES 5:



MEDA sizes 3-48 thru 3/4 - 16 available.  
See our website or inquire.



Size	TPI	No. of Flutes	Ground Thread Limit	Order No.		Price
				Plug	Bottom	
3	48	2	H2	0703481	0703482	
3	56	2	H2	0703561	0703562	
4	40	2	H2	0704401	0704402	
4	48	2	H2	0704481	0704482	
5	40	2	H2	0705401	0705402	
5	44	2	H2	0705441	0705442	
6	32	2	H3	0706321	0706322	
6	40	2	H3	0706401	0706402	
8	32	3	H3	0708321	0708322	
8	36	3	H3	0708361	0708362	
10	24	3	H3	0710241	0710242	
10	32	3	H3	0710321	0710322	
12	24	3	H3	0712241	0712242	
12	28	3	H3	0712281	0712282	
1/4	20	3	H3	0716201	0716202	
1/4	28	3	H3	0716281	0716282	
5/16	18	3	H3	0720181	0720182	
5/16	24	3	H3	0720241	0720242	
3/8	16	3	H3	0724161	0724162	
3/8	24	3	H3	0724241	0724242	
7/16	14	3	H3	0728141	0728142	
7/16	20	3	H3	0728201	0728202	
1/2	13	3	H3	0732131	0732132	
1/2	20	3	H3	0732201	0732202	
9/16	12	3,4	H3	0736121	0736122	
9/16	18	3,4	H3	0736181	0736182	
5/8	11	4	H3	0740111	0740112	
5/8	18	4	H3	0740181	0740182	
11/16	11	4	H3	0744111	0744112	
11/16	16	4	H3	0744161	0744162	
3/4	10	4	H3	0748101	0748102	
3/4	16	4	H3	0748161	0748162	

Size	TPI	No. of Flutes	Ground Thread Limit	Order No.		Price
				Plug	Bott	
4	40	2	H2	365676	365678	
5	40	2	H2	9200541	9200542	
6	32	2	H3	365648	365655	
8	32	3	H3	365689	365697	
10	24	3	H3	365721	365739	
10	32	3	H3	365747	365754	
1/4	20	3	H3	366323	366331	
1/4	28	3	H3	366364	366372	
5/16	18	3	H3	366406	366414	
5/16	24	3	H3	366448	366455	
3/8	16	3	H3	366463	366471	
3/8	24	3	H3	366489	366497	
7/16	14	3	H3	366505	366513	
7/16	20	3	H3	366521	366538	
1/2	13	3	H3	366547	366554	
1/2	20	3	H3	366562	366570	

‡ Available Gold (TIN) Coated; please inquire.

## HIGH SPEED STEEL / GROUND THREAD 49° QUICK SPIRAL FLUTED TAPS

SERIES 920 :

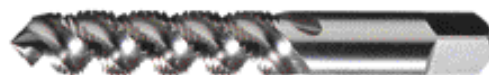

Spiral Fluted Taps (also known as Helical Fluted Taps) are designed to provide efficient chip ejection in a wide variety of soft materials such as aluminum, copper, brass, magnesium, die casting metals, and steel in which stringy chips are generated. These taps are particularly useful in threading deep or blind holes, and in bridging keyways or other interruptions in the surface of holes being tapped.

## HIGH SPEED STEEL / GROUND THREAD 49° QUICK SPIRAL FLUTED TAPS

GOLD (TIN) COATED  
SERIES 920 :



Size	TPI	No. of Flutes	Ground Thread Limit	Order No.		Price
				Plug	Bott	
4	40	2	H2	367145	367152	
6	32	2	H3	367228	367236	
8	32	3	H3	367269	367278	
10	24	3	H3	367302	367320	
10	32	3	H3	367327	367335	
1/4	20	3	H3	367905	367913	
1/4	28	3	H3	367921	367939	
5/16	18	3	H3	367947	367954	
5/16	24	3	H3	367962	367970	
3/8	16	3	H3	367988	367996	
3/8	24	3	H3	368038	368039	
7/16	14	3	H3	368043	368036	
1/2	13	3	H3	368069	368077	
5/8	11	4	H3	368145	368091	

Size	TPI	No. of Flutes	Ground Thread Limit	Order No.		Price
				Plug	Bottom	
3	48	2	H2	367107	367115	
4	40	2	H2	367149	367156	
5	40	2	H2	367180	367198	
6	32	2	H3	367222	367230	
8	32	3	H3	367263	367271	
10	24	3	H3	367305	367313	
10	32	3	H3	367321	367339	
12	24	3	H3	367347	367354	
1/4	20	3	H3	367909	367917	
1/4	28	3	H3	367925	367933	
5/16	18	3	H3	367941	367958	
5/16	24	3	H3	367966	367974	
3/8	16	3	H3	367982	367990	
3/8	24	3	H3	368006	368014	
7/16	14	3	H3	9368022	368030	
7/16	20	3	H3	368048	368055	
1/2	13	3	H3	368063	368071	
1/2	20	3	H3	368089	368097	
5/8	11	4	H3	368147	368154	



HIGH SPEED STEEL / GROUND THREAD

**49° QUICK SPIRAL FLUTED**

**TAPS - METRIC**

SERIES 920 :

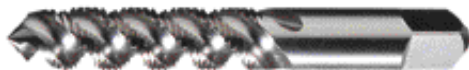

Size mm	Pitch mm	Pitch Dia. Limit	No. of Flutes	Order No.		Price
				Plug	Bott	
3.0	.50	D3	2	366110	366112	
3.5	.60	D4	3	366120	366122	
4.0	.70	D4	3	366130	366132	
5.0	.80	D4	3	366140	366142	
6.0	1.00	D5	3	366150	366152	
8.0	1.25	D5	3	366160	366162	
10.0	1.50	D6	3	366170	366172	
12.0	1.75	D6	3	366180	366182	

HIGH SPEED STEEL / GROUND THREAD

**S.T.I. (SCREW THREAD INSERT) TAPS**

SERIES 935:



Nominal Thread Size	Straight Flute					
	Plug Style (3B)			Bottoming Style (3B)		
	Model No.	Order No.	Price	Model No.	Order No.	Price
2-56	TP02-CPB	0110256		TP02-CBB	0120256	
3-48	TP03-CPB	0110348		TP03-CBB	0120348	
3-56	TP03-FPB	0110356		TP03-FBB	9120356	
4-40	TP04-CPB	0110440		TP04-CBB	0120440	
4-48	TP04-FPB	0110448		TP04-FBB	9120448	
5-40	TP05-CPB	0110540		TP05-CBB	0120540	
6-32	TP06-CPB	0110632		TP06-CBB	0120632	
6-40	TP06-FPB	0110640		TP06-FBB	0120640	
8-32	TP2-CPB	0110832		TP2-CBB	0120832	
8-36	TP2-FPB	0110836		TP2-FBB	0120836	
10-24	TP3-CPB	9011024		TP3-CBB	0121024	
10-32	TP3-FPB	9011032		TP3-FBB	0121032	
12-24	TP1-CPB	0111224		TP1-CBB	0121224	
12-28	TP1-FPB	9011228		TP1-FBB	0121228	
1/4-20	TP4-CPB	0111620		TP4-CBB	0121620	
1/4-28	TP4-FPB	0111628		TP4-FBB	9121628	
5/16-18	TP5-CPB	0112018		TP5-CBB	0122018	
5/16-24	TP5-FPB	0112024		TP5-FBB	0122024	
3/8-16	TP6-CPB	0112416		TP6-CBB	0122416	
3/8-24	TP6-FPB	0112424		TP6-FBB	0122424	
7/16-14	TP7-CPB	0112814		TP7-CBB	0122814	
7/16-20	TP7-FPB	0112820		TP7-FBB	0122820	
1/2-13	TP8-CPB	0113213		TP8-CBB	0123213	
1/2-20	TP8-FPB	0113220		TP8-FBB	0123220	
9/16-12	TP9-CPB	0113612		TP9-CBB	0123612	
9/16-18	TP9-FPB	0113618		TP9-FBB	0123618	
5/8-11	TP10-CPB	0114011		TP10-CBB	0124011	
5/8-18	TP10-FPB	0114018		TP10-FBB	0124018	
3/4-10	TP12-CPB	0114810		TP12-CBB	0124810	
3/4-16	TP12-FPB	0114816		TP12-FBB	9124816	
7/8-9	TP14-CPB	0115609		TP14-CBB	0125609	
7/8-14	TP14-FPB	0115614		TP14-FBB	0125614	
1-8	TP16-CPB	0116408		TP16-CBB	0126408	
1-12	TP161-FPB	0116412		TP161-FBB	0126412	
1-14	TP16-FPB	0116414		TP16-FBB	0126414	
1-1/8-7	TP18-CPB	0117207		TP18-CBB	0127207	
1-1/8-12	TP18-FPB	0117212		TP18-FBB	0127212	
1-1/4-7	TP20-CPB	0118007		TP20-CBB	0128007	
1-1/4-12	TP20-FPB	9018012		TP20-FBB	0128012	
1-3/8-6	TP22-CPB	0118806		TP22-CBB	0128806	
1-3/8-12	TP22-FPB	0118812		TP22-FBB	0128812	
1-1/2-6	TP24-CPB	9019606		TP24-CBB	0129606	
1-1/2-12	TP24-FPB	0119612		TP24-FBB	0129612	

HIGH SPEED STEEL / GROUND THREAD

**THREAD FORMING**

**TAPS - FLUTELESS**

SERIES 557:



Size	TPI	Order No.	Price
2	56	5570256	
2	64	464264	
3	48	464348	
3	56	464356	
4	40	5570440	
4	48	464448	
5	40	5570540	
5	44	464544	
6	32	5570632	
6	40	464640	
8	32	5570832	
8	36	464836	
10	24	5571024	
10	32	5571032	
12	24	464924	
12	28	464928	
1/4	20	5571620	
1/4	28	5571628	
5/16	18	5572018	
5/16	24	5572024	
3/8	16	5572416	
3/8	24	5572424	
7/16	14	5572814	
7/16	20	5572820	
1/2	13	5573213	
1/2	20	5573220	
3/4	16	465460	
7/8	14	465490	



**Plug Style**

4 Thread Chamfer-For thru holes and in blind holes that allow for ample chip clearance. Easier starting and requires less tapping torque than bottoming taps.



**Bottoming Style**

2 Thread Chamfer - For blind holes drilled to a minimum depth that requires threads close to the bottom of the hole.



HIGH SPEED STEEL / GROUND THREAD

## S.T.I. (SCREW THREAD INSERT) TAPS

SERIES 935:

Nominal Thread Size	SPIRAL POINT			SPIRAL FLUTE		
	Plug Style (3B)			Bottoming Style (3B)		
	Model No.	Order No.	Price	Model No.	Order No.	Price
2-56	TP02-CSB	0210256		TP02-CFB	0310256	
3-48	TP03-CSB	0210348		TP03-CFB	0310348	
4-40	TP04-CSB	0210440		TP04-CFB	0310440	
4-48	TP04-FSB	0210448		TP04-FFB	0310448	
5-40	TP05-CSB	0210540		TP05-CFB	0310540	
6-32	TP06-CSB	0210632		TP06-CFB	0310632	
6-40	TP06-FSB	0210640		TP06-FFB	0310640	
8-32	TP2-CSB	0210832		TP2-CFB	0310832	
8-36	TP2-FSB	0210836		TP2-FFB	0310836	
10-24	TP3-CSB	0211024		TP3-CFB	0311024	
10-32	TP3-FSB	0211032		TP3-FFB	0311032	
12-24	TP1-CSB	0211224		TP1-CFB	0311224	
1/4-20	TP4-CSB	0211620		TP4-CFB	0311620	
1/4-28	TP4-FSB	0211628		TP4-FFB	0311628	
5/16-18	TP5-CSB	0212018		TP5-CFB	0312018	
5/16-24	TP5-FSB	0212024		TP5-FFB	0312024	
3/8-16	TP6-CSB	0212416		TP6-CFB	0312416	
3/8-24	TP6-FSB	0212424		TP6-FFB	0312424	
7/16-14	TP7-CSB	0212814		TP7-CFB	0312814	
7/16-20	TP7-FSB	0212820		TP7-FFB	0312820	
1/2-13	TP8-CSB	0213213		TP8-CFB	0313213	
1/2-20	TP8-FSB	0213220		TP8-FFB	0313220	



### Spiral Pointed Plug

4 Thread Chamfer - Incorporates an angular grind at the point end of the tap which shears chips and drives them forward of the tap. Used widely in long thru holes and blind holes with ample chip clearance. They are free cutting and provide increased tap strength. Not recommended for abrasive material.



### High Spiral Flute - Bottoming

2 Thread Chamfer - Spiral flute for efficiently pulling stringy chips out of deep or blind holes in soft materials.



HIGH SPEED STEEL / GROUND THREAD

## S.T.I. (SCREW THREAD INSERT) TAPS - METRIC SIZES

SERIES 935:

Nominal Thread Size	STRAIGHT FLUTE					
	Plug Style (5H)			Bottoming Style (5H)		
	Model No.	Order No.	Price	Model No.	Order No.	Price
M2.5 x .45	TP2.5M-CPA	0110204		TP2.5M-CBA	0120204	
M3 x .5	TP3M-CPA	0110305		TP3M-CBA	0120305	
M4 x .7	TP4M-CPA	9110407		TP4M-CBA	0120407	
M5 x .8	TP5M-CPA	0110508		TP5M-CBA	0120508	
M6 x 1.0	TP6M-CPA	0110610		TP6M-CBA	0120610	
M7 x 1.0	TP7M-CPA	0110710		TP7M-CBA	0120710	
M8 x 1.0	TP8M-FPA	0110810		TP8M-FBA	0120810	
M8 x 1.25	TP8M-CPA	0110812		TP8M-CBA	0120812	
M9 x 1.25	TP9M-CPA	0110912		TP9M-CBA	0120912	
M10 x 1.0	TP10M-FPA	0111010		TP10M-FBA	0121010	
M10 x 1.25	TP10M-MPA	0111012		TP10M-MBA	0121012	
M10 x 1.5	TP10M-CPA	0111015		TP10M-CBA	0121015	
M11 x 1.0	TP11M-FPA	0111110		TP11M-FBA	0121110	
M11 x 1.25	TP11M-MPA	9111112		TP11M-MBA	0121112	
M11 x 1.5	TP11M-CPA	9011115		TP11M-CBA	0121115	
M12 x 1.25	TP12M-FPA	0111212		TP12M-FBA	0121212	
M12 x 1.5	TP12M-MPA	0111215		TP12M-MBA	0121215	
M12 x 1.75	TP12M-CPA	0111217		TP12M-CBA	0121217	
M14 x 1.5	TP14M-FPA	0111415		TP14M-FBA	0121415	
M14 x 2.0	TP14M-CPA	9111420		TP14M-CBA	0121420	
M16 x 1.5	TP16M-FPA	0111615		TP16M-FBA	0121615	
M16 x 2.0	TP16M-CPA	9011620		TP16M-CBA	9021620	
M18 x 1.5	TP18M-FPA	0111815		TP18M-FBA	0121815	
M18 x 2.5	TP18M-CPA	0111825		TP18M-CBA	0121825	
M20 x 1.5	TP20M-FPA	0112015		TP20M-FBA	0122015	
M20 x 2.5	TP20M-CPA	0112025		TP20M-CBA	0122025	
M24 x 3.0	TP24M-CPA	0112430		TP24M-CBA	0122430	



### Plug Style

4 Thread Chamfer-For thru holes and in blind holes that allow for ample chip clearance. Easier starting and requires less tapping torque than bottoming taps.



### Bottoming Style

2 Thread Chamfer - For blind holes drilled to a minimum depth that requires threads close to the bottom of the hole.

HIGH SPEED STEEL / GROUND THREAD

**S.T.I. (SCREW THREAD INSERT) TAPS - METRIC SIZES**

SERIES 935:



Nominal Thread Size	Spiral Point (5H)			High Spiral Flute (5H)		
	Model No.	Order No.	Price	Model No.	Order No.	Price
M2.5 x .45	TP2.5M-CSA	0210204		TP2.5M-CFA	0320204	
M3 x .5	TP3M-CSA	0210305		TP3M-CFA	0320305	
M4 x .7	TP4M-CSA	0210407		TP4M-CFA	0320407	
M5 x .8	TP5M-CSA	0210508		TP5M-CFA	0320508	
M6 x 1.0	TP6M-CSA	0210610		TP6M-CFA	0320610	
M8 x 1.0	TP8M-FSA	0210810		TP8M-FFA	0320810	
M8 x 1.25	TP8M-CSA	0210812		TP8M-CFA	0320812	
M10 x 1.0	TP10M-FSA	0211010		TP10M-FFA	0321010	
M10 x 1.25	TP10M-MSA	0211012		TP10M-MFA	0321012	
M10 x 1.5	TP10M-CSA	0211015		TP10M-CFA	0321015	
M12 x 1.25	TP12M-FSA	0211212		TP12M-FFA	0321212	
M12 x 1.5	TP12M-MSA	0211215		TP12M-MFA	0321215	
M12 x 1.75	TP12M-CSA	0211217		TP12M-CFA	0321217	



**Spiral Pointed Plug**

4 Thread Chamfer - Incorporates an angular grind at the point end of the tap which shears chips and drives them forward of the tap. Used widely in long thru holes and blind holes with ample chip clearance. They are free cutting and provide increased tap strength. Not recommended for abrasive material.



**High Spiral Flute - Bottoming**

2 Thread Chamfer - Spiral flute for efficiently pulling stringy chips out of deep or blind holes in soft materials.

HIGH SPEED STEEL /GROUND THREAD

**DRILL / TAP COMBINATION**

SERIES 324: STAR USA

SERIES 949: MEDA - SUPERIOR IMPORT

INCH SIZES



Size	Pitch	OAL	Thread Length	Drill Length	Drill Size	MEDA		STAR USA	
						Order No.	Price	Order No.	Price
4-40	H2	1-7/8	3/8	1/4	.0910	5780005		3240440	
4-48	H2	1-7/8	3/8	1/4	.0945	5780010		3240448	
5-40	H2	1-15/16	13/32	9/32	.1040	5780015		3240540	
5-44	H2	1-15/16	13/32	9/32	.1060	5780020		3240544	
6-32	H3	2	7/16	5/16	.1115	5780025		3240632	
6-40	H3	2	7/16	5/16	.1170	5780030		3240640	
8-32	H3	2-1/8	1/2	3/8	.1375	5780035		3240832	
8-36	H3	2-1/8	1/2	3/8	.1405	5780040		3240836	
10-24	H3	2-3/8	5/8	13/32	.1545	5780045		3241024	
10-32	H3	2-3/8	5/8	13/32	.1635	5780050		3241032	
12-24	H3	2-3/8	21/32	15/32	.1805	5780055		3241224	
12-28	H3	2-3/8	21/32	15/32	.1860	5780060		3241228	
1/4-20	H3	2-1/2	25/32	17/32	.2080	5780065		3241620	
1/4-28	H3	2-1/2	25/32	17/32	.2200	5780070		3241628	
5/16-18	H3	2-27/32	15/16	11/16	.2660	5780075		3242018	
5/16-24	H3	2-27/32	15/16	11/16	.2770	5780080		3242024	
3/8-16	H3	3-3/8	1-1/16	13/16	.3225	5780085		3242416	
3/8-24	H3	3-3/8	1-1/16	13/16	.3395	5780090		3242424	
7/16-14	H3	3-3/4	1-1/4	1	.3770	5780095		3242814	
7/16-20	H3	3-3/4	1-1/4	1	.3955	5780100		3242820	
1/2-13	H3	4-1/16	1-3/8	1-1/8	.4350	5780105		3243213	
1/2-20	H3	4-1/16	1-3/8	1-1/8	.4580	5780110		3243220	



Drills and Taps in a single pass. Point is self-centering and eliminates the need for center drilling or center punching.

Can be used on multi-spindle heads with reversing mechanisms in most materials. 2 Flutes, Taper pipe sizes available; please inquire.

METRIC SIZES

Size	Pitch Dia.	Overall Length Inches	Drill Length Inches	Drill Size Inches	Thread Length Inches	MEDA		STAR USA	
						Order No.	Price	Order No.	Price
M3 x0.5	D3	1-15/16	9/32	.1015	13/32	5782005		2403050	
M3.5 x 0.6	D4	2	5/16	.1180	7/16	5782010		2403560	
M4 x 0.7	D4	2-1/8	3/8	.1340	1/2	5782015		2404070	
M4.5 x 0.75	D4	2-3/8	13/32	.1520	5/8	5782020		2404575	
M5 x 0.8	D4	2-3/8	13/32	.1700	5/8	5782025		2405080	
M6 x 1	D5	2-1/2	17/32	.2030	25/32	5782030		2406010	
M7 x 1	D5	2-27/32	11/16	.2420	15/16	5782035		2407010	
M8 x 1.25	D5	2-27/32	11/16	.2735	15/16	9782040		2408012	
M10 x 1.5	D6	3-3/8	13/16	.3440	1-1/16	5782045		2410150	
M12 x 1.75	D6	4-1/16	1-1/8	.4140	1-3/8	5782150		2412175	

CUTTING TOOLS - TAPS & DIES

HIGH SPEED STEEL / GROUND THREAD

## PIPE TAPS

SERIES 9: TAPER (N.P.T. STANDARD & GOLD (TIN) COATED & N.P.T.F.)

SERIES 10: STRAIGHT ( N.P.S. & N.P.S.F.)



Size	Threads Per Inch	No. Of Flutes	NPT		NPTF		NPT(Gold)		NPS		NPSF	
			Order No.	Price	Order No.	Price	Order No.	Price	Order No.	Price	Order No.	Price
1/16	27	4	1005004		1505004		1515004		1010004		-	
1/8	27	4	1005008		1505008		1515008		1010008		9030008	
1/4	18	4	1005016		1505016		1515016		1010016		1030016	
3/8	18	4	1005024		1505024		9515024		1010024		1030024	
1/2	14	4	1005032		1505032		1515032		1010032		1030032	
3/4	14	5	1005048		1505048		9515048		1010048		1030048	
1	11-1/2	5	1005064		1505064		1515064		1010064		1030064	
1-1/4	11-1/2	5	1005080		1505080		1515080		1010080		1030080	
1-1/2	11-1/2	7	1005096		1505096		1515096		1010096		1030096	
2	11-1/2	7	1005200		1505200		1515200		1010200		9030200	
2-1/2	8	8	1005232		1505232				9910232		1030232	
3	8	8	1005300		1505300				8010300		1030300	
3-1/2	8	8	1005332		-				466516			
4	8	8	1005399		-				466517			

HIGH SPEED STEEL / GROUND THREAD

## TAPER PIPE TAPS

INTERRUPTED THREAD

SERIES 11: N.P.T. & N.P.T.F.



HIGH SPEED STEEL / GROUND THREAD

## PIPE TAPS - BRITISH STANDARD

55° THREAD ANGLE

SERIES 943:



Size	Threads Per Inch	No. of Flutes	NPT		NPTF	
			Order No.	Price	Order No.	Price
1/16	27	4	1015004		1035004	
1/8	27	4	1015008		1035008	
1/4	18	4	1015016		1035016	
3/8	18	4	1015024		1035024	
1/2	14	4	1015032		1035032	
3/4	14	5	1015048		1035048	
1	11-1/2	5	1015064		1035064	
1-1/4	11-1/2	5	1015080		1035080	
1-1/2	11-1/2	7	1015096		1035096	
2	11-1/2	7	1015200		1035200	

Size	Threads Per Inch	Straight Pipe B.S.P.F.(P)		Taper Pipe B.S.P.T.	
		Order No.	Price	Order No.	Price
1/8	28	9430008		9431008	
1/4	19	9430016		9431016	
3/8	19	9430024		9431024	
1/2	14	9430032		9431032	
5/8	14	9930040		9431040	
3/4	14	9430048		9431048	
7/8	14	9430056		9431056	
1	11	9430100		9431100	
1-1/4	11	9430116		9431116	
1-1/2	11	9430132		9431132	
1-3/4	11	9430148		9431148	
2	11	9430200		9431200	

HIGH SPEED STEEL / GROUND THREAD

## TAPER PIPE TAPS

SERIES 797 :



CARBON STEEL

## TAPER PIPE TAPS

SERIES 945: TAPER (N.P.T.)



Size	Threads Per Inch	No. of Flutes	NPT		NPTF	
			Order No.	Price	Order No.	Price
1/16	27	4	7970004		385323	
1/8	27	4	7970008		385380	
1/4	18	4	7970016		385413	
3/8	18	4	7970024		385448	
1/2	14	4	7970032		385471	
3/4	14	5	7970048		385505	
1	11-1/2	5	7970064		385539	
1-1/4	11-1/2	5	7970080		385562	
1-1/2	11-1/2	7	7970096		385596	
2	11-1/2	7	7970200		385620	

Size	Threads Per inch	No. of Flutes	MEDA		STAR USA	
			Order No.	Price	Order No.	Price
1/16	27	4	8450004		9451004	
1/8	27	4	9450008		9451008	
1/4	18	4	9450016		9451016	
3/8	18	4	9450024		9451024	
1/2	14	4	9450032		9451032	
3/4	14	5	9450048		9451048	
1	11-1/2	5	9450064		9451064	
1-1/4	11-1/2	5	9450080		9451080	
1-1/2	11-1/2	7	9450096		9451096	
2	11-1/2	7	9450200		9451200	
2-1/2	8	8	9450232		-	
3	8	8	9450300		-	
3-1/2	8	8	9450332		-	
4	8	8	9450399		-	

HIGH SPEED STEEL / GROUND THREAD

**STRAIGHT PIPE TAPS**

SERIES 921:



Size	T.P.I.	No. of Flutes	Order No.		Price
			NPS	NPSF	
1/8	27	4	387113	387220	
1/4	18	4	387121	387238	
3/8	18	4	387139	387246	
1/2	14	4	387147	387253	
3/4	14	5	387154	387261	
1	11-1/2	5	387162	387279	
1-1/4	11-1/2	5	-	9210080	
1-1/2	11-1/2	7	-	9210096	
2	11-1/2	7	-	9210200	

HIGH SPEED STEEL / GROUND THREAD

**TAPER PIPE TAPS - STANDARD & INTERRUPTED**

GOLD (TIN) COATED  
SERIES 921:



Size	Threads Per Inch	No. Of Flutes	Standard			Interrupted	
			NPT	NPTF	Price	NPTF	Price
1/16	27	4	385328	385329			
1/8	27	4	385385	385386		385755	
1/4	18	4	385409	385410		385789	
3/8	18	4	385443	385444		385813	
1/2	14	4	385458	385477		385847	
3/4	14	5	385500	385501		385870	
1	11-1/2	5	385534	385536		385904	
1-1/4	11-1/2	5	385680	385685			
1-1/2	11-1/2	7	385681	385686			
2	11-1/2	7	385682	385687			

HIGH SPEED STEEL / GROUND THREAD

**TAPER PIPE TAPS - INTERRUPTED THREAD**

SERIES 921:



Size	T.P.I.	No. of Flutes	Order No.		Price
			NPT	NPTF	
1/8	27	4	385737	385752	
1/4	18	4	385760	385786	
3/8	18	4	385794	385810	
1/2	14	4	385828	385844	
3/4	14	5	385851	385877	
1	11-1/2	5	385885	385901	
1-1/4	11-1/2	5	385919	-	
1-1/2	11-1/2	7	385943	-	

HIGH SPEED STEEL / GROUND THREAD

**CNC LONG TAPER PIPE TAPS**

OVERALL LENGTH: 6", STANDARD AND GOLD (TIN) COATED  
SERIES 921:



Size	Threads Per Inch	No. Of Flutes	Overall Length	Standard			Gold	
				NPT	NPTF	Price	NPTF	Price
1/8	27	4	3	384524	386008		386129	
1/4	18	4	3-1/2	384525	386024		386152	
3/8	18	4	3-3/4	384526	386040		386186	
1/2	14	4	4-3/8	384527	386065		386210	
3/4	14	5	4-5/8	384528	-		-	
1	11-1/2	5	5-1/4	384529	-		-	

HIGH SPEED STEEL / GROUND THREAD

**LONG TAPER PIPE TAPS - (NPT)**

OVERALL LENGTHS:

6", 8" & 12"

SERIES 550:



Size	Threads Per Inch	Overall Length							
		4"		6"		8"		12"	
		Order No.	Price	Order No.	Price	Order No.	Price	Order No.	Price
1/8	27	5504008		5506008		5508008		467902	
1/4	18	5504016		5506016		5508016		5501216	
3/8	18			5506024		-		5501224	
1/2	14			5506032		-		5501232	
3/4	14			5506048		5508048		5501248	
1	11-1/2			5506064		5508064		5501264	

HIGH SPEED STEEL / GROUND THREAD

**STRAIGHT FLUTE**

**BSW - TAPS**

SERIES 943: Plug Style

Size	Threads Per inch	No. of Flutes	Order No.	Price
3/16	24	3	9431224	
1/4	20	3	9431620	
5/16	18	4	9432018	
3/8	16	4	9432416	
7/16	14	4	9432814	
1/2	12	4	9543212	
9/16	12	4	9433612	
5/8	11	4	9434011	
3/4	10	4	9434810	
7/8	9	4	9435609	
1	8	4	9436408	



HIGH SPEED STEEL / GROUND THREAD

**STRAIGHT FLUTE**

**BSC - TAPS**

(BRITISH CYCLE THREAD)

SERIES 943: Plug Style

Size	Threads Per inch	No. of Flutes	Order No.	Price
1/4	26	3	9432616	
5/16	26	4	9432620	
3/8	26	4	9432624	
7/16	26	4	9432628	
1/2	26	4	9432632	

HIGH SPEED STEEL / GROUND THREAD

**STRAIGHT FLUTE**

**BSF - TAPS**

SERIES 943: Plug Style

Size	Threads Per inch	No. of Flutes	Order No.	Price
3/16	32	3	9435012	
1/4	26	3	9435016	
5/16	22	4	9435020	
3/8	20	4	9435024	
7/16	18	4	9435028	
1/2	16	4	9435032	

## BURR-BIT SERIES 189:



Taps and deburrs in one operation! Saves tool changes and machine cycles.

- Eliminates expensive secondary deburring.
- Deburrs the top of the tapped hole as the tap is being withdrawn from the workpiece.
- Cuts in reverse only for a smooth clean chamfer.
- Independent Burr-Bit spring pressure produces same-depth chamfer every time.
- Repeatable results for thousands of cycles!
- Easy to install. Simply slips over the tap.
- Easily resharpenable on radial relief grinding fixture.
- 120° included angle; 90° available.

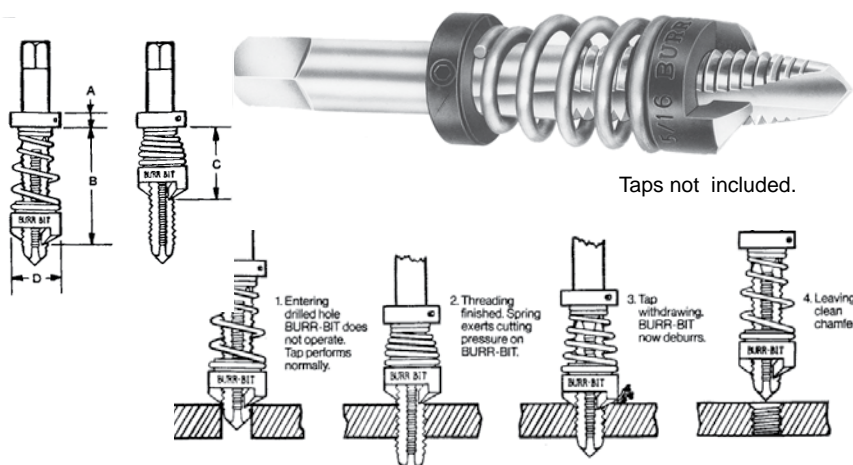

Taps not included.

### BURR-BITS FOR THREE FLUTE TAPS - INCH & METRIC

Tap Size	A (In)	B (In)	C (In)	D (In)	Order No. 120°	Price
#2-3FL	11/64	7/8	45/64	3/8	8902025	
#3-3FL	11/64	7/8	45/64	3/8	8902035	
#4-3FL	11/64	7/8	45/64	3/8	8902045	
#5-3FL	11/64	55/64	23/32	3/8	8902055	
#6-3FL	11/64	55/64	23/32	3/8	8902065	
#8-3FL	11/64	7/8	45/64	3/8	8902075	
#10-3FL	11/64	1-1/16	25/32	3/8	8902085	
#12-3FL	11/64	1-1/16	25/32	3/8	8902095	
1/4-3FL	11/64	1-9/64	7/8	1/2	8902115	
5/16-3FL	11/64	1-1/4	61/64	9/16	8902125	
3/8-3FL	11/64	1-1/4	61/64	21/32	8902135	
7/16-3FL	11/64	1-27/32	1-11/32	13/16	8902145	
1/2-3FL	11/64	1-47/64	1-15/64	13/16	8902155	
9/16-3FL	7/32	1-23/32	1-7/32	1	8902165	
5/8-3FL	7/32	1-57/64	1-19/64	1	8902175	
3/4-3FL	7/32	2-5/64	1-3/8	1-1/8	8902195	
M3-3FL	11/64	55/64	23/32	3/8	8903035	
M4-3FL	11/64	7/8	45/64	3/8	8903045	
M5-3FL	11/64	1-1/16	25/32	3/8	8903055	
M6-3FL	11/64	1-9/64	7/8	1/2	8903065	
M8-3FL	11/64	1-1/4	61/64	9/16	8903085	
M10-3FL	11/64	1-1/4	61/64	21/32	8903105	
M12-3FL	11/64	1-27/32	1-11/32	13/16	8903125	
M14-3FL	7/32	1-23/32	1-7/32	1	8903145	
M16-3FL	7/32	1-57/64	1-19/64	1	8903165	
M18-3FL	7/32	2	1	1-1/8	8903185	

### BURR-BITS FOR TWO & FOUR FLUTE TAPS - INCH & METRIC

Tap Size	A (In)	B (In)	C (In)	D (In)	Order No. 120°	Price
#2-2FL	11/64	7/8	45/64	3/8	8902020	
#3-2FL	11/64	7/8	45/64	3/8	8902030	
#4-2FL	11/64	7/8	45/64	3/8	8902040	
#5-2FL	11/64	55/64	23/32	3/8	8902050	
#6-2FL	11/64	55/64	23/32	3/8	8902060	
#8-2FL	11/64	7/8	45/64	3/8	8902070	
#10-2FL	11/64	1-1/16	25/32	3/8	8902080	
#12-2FL	11/64	1-1/16	25/32	3/8	8902090	
1/4-2FL	11/64	1-9/64	7/8	1/2	8902110	
5/16-2FL	11/64	1-1/4	61/64	9/16	8902120	
3/8-2FL	11/64	1-1/4	61/64	21/32	8902130	
7/16-2FL	11/64	1-27/32	1-11/32	13/16	8902140	
1/2-2FL	11/64	1-47/64	1-15/64	13/16	8902150	
9/16-2FL	7/32	1-23/32	1-7/32	1	8902160	
5/8-2FL	7/32	1-57/64	1-19/64	1	8902170	
11/16-2FL	7/32	1-57/64	1-19/64	1-1/8	8902180	
3/4-2FL	7/32	2-5/64	1-3/8	1-1/8	8902190	
7/8-4FL	7/32	2-3/16	1-31/64	1-1/2	8902210	
1-4FL	7/32	2-5/8	1-25/32	1-1/2	8902230	
M3-2FL	11/64	55/64	23/32	3/8	8903030	
M4-2FL	11/64	7/8	45/64	3/8	8903040	
M5-2FL	11/64	1-1/16	25/32	3/8	8903050	
M6-2FL	11/64	1-9/64	7/8	1/2	8903060	
M8-2FL	11/64	1-1/4	61/64	9/16	8903080	
M10-2FL	11/64	1-1/4	61/64	21/32	8903100	
M12-2FL	11/64	1-27/32	1-11/32	13/16	8903120	
M14-2FL	7/32	1-23/32	1-7/32	1	8903140	
M16-2FL	7/32	1-57/64	1-19/64	1	8903160	
M18-2FL	7/32	2	1	1-1/8	8903180	
M20-2FL	7/32	2-3/16	1-31/64	1-1/2	8903200	
M22-2FL	7/32	2-13/64	1-7/16	1-1/2	8903220	
M24-2FL	7/32	2-13/64	1-7/16	1-1/2	8903240	



## BURR-BIT SERIES 189:

### PIPE TAP BURR-BITS (NPT OR NPS)

Size	Collar ID(In)	O.D. (In)	Relaxed Lgth (In)	Compressed Lgth	Order No.	Price
1/8	.437	21/32	1-1/16	5/8	8904110	
1/4	.562	13/16	1-5/16	3/4	8904120	
3/8	.700	1-1/8	1-5/16	7/8	8904130	
1/2	NONE	1-1/2	1-1/2	7/8	8904140	
3/4	NONE	1-1/2	1-1/2	7/8	8904150	
1	NONE	1-7/8	1-7/8	1-7/8	8904160	

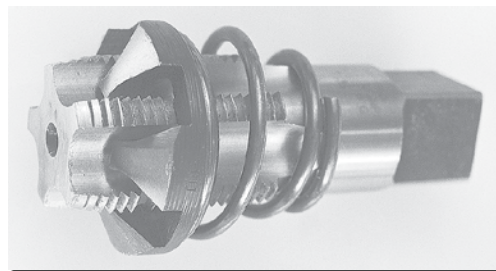

H.S.S. / SCREW ADJUSTABLE  
**STANDARD THREAD**  
**ROUND SPLIT DIES**  
 SERIES 12:



(Continued)

Size	Threads Per Inch	Order No.
<b>13/16" O.D. Price</b>		
0	80	1000800
1	64	1001640
1	72	1001720
2	56	1002560
2	64	1002640
3	48	1003480
3	56	1003560
4	40	1004400
4	48	1004480
5	40	1005400
5	44	1005440
6	32	1006320
6	40	1006400
8	32	1008320
8	36	1008360
10	24	1010240
10	32	1010320
12	24	1012240
12	28	1012280
1/4	20	1016200
1/4	28	1016280
5/16	18	1020180
5/16	24	1020240
<b>1" O.D. Price</b>		
3	48	1003481
4	40	1004401
4	48	1004481
5	40	1005401
5	44	1005441
6	32	1006321
6	40	1006401
8	32	1008321
8	36	1008361
10	24	1010241
10	32	1010321
12	24	1012241
12	28	1012281
1/4	20	1016201
1/4	28	1016281
5/16	18	1020181
5/16	24	1020241
3/8	16	1024161
3/8	24	1024241
7/16	14	1028141
7/16	20	1028201
1/2	13	1032131
1/2	20	1032201
<b>1-1/2" O.D. Price</b>		
1/4	20	1016202
1/4	28	1016282
5/16	18	1020182
5/16	24	1020242
3/8	16	1024162
3/8	24	1024242

Size	Threads Per Inch	Order No.
<b>1-1/2" O.D. Price</b>		
7/16	14	1028142
7/16	20	1028202
1/2	13	1032132
1/2	20	1032202
9/16	12	1036122
9/16	18	1036182
5/8	11	1040112
5/8	18	1040182
11/16	11	1044112
11/16	16	1044162
3/4	10	1048102
3/4	16	1048162
<b>2" O.D. Price</b>		
1/4	20	1016203
1/4	28	1016283
5/16	18	1020183
5/16	24	1020243
3/8	16	1024163
3/8	24	1024243
7/16	14	1028143
7/16	20	1028203
1/2	13	1032133
1/2	20	1032203
9/16	12	1036123
9/16	18	1036183
5/8	11	1040113
5/8	18	1040183
3/4	10	1048103
3/4	16	1048163
7/8	9	1056093
7/8	14	1056143
1	8	1064083
1	12	1064123
1	14	1064143
<b>2-1/2" O.D. Price</b>		
3/4	10	1048104
7/8	14	1056144
1	8	1064084
1-1/8	7	1072074
1-1/8	12	1072124
1-1/4	7	1079074
1-1/4	12	1080124
1-3/8	6	1088064
1-3/8	12	1088124
1-1/2	6	1096064
1-1/2	12	1096124
<b>3" O.D. Price</b>		
1	8	1064085
1	12	1064125
1	14	1064145
1-1/8	7	1072075
1-1/8	12	1072125
1-1/4	7	1080705
1-1/4	12	1080125
1-3/8	6	1088065
1-3/8	12	1088125
1-1/2	6	1096065
1-1/2	12	1096125

H.S.S. / SCREW ADJUSTABLE  
**SPECIAL THREAD**  
**ROUND SPLIT DIES**  
 SERIES 13:

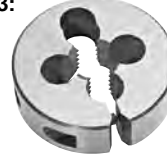

Size	Threads Per Inch	Order No.
<b>13/16" O.D. Price \$5.90</b>		
1	56	1501560
1	80	1501800
2	72	1502720
2	80	1502800
4	56	1504560
4	72	1504720
4	80	1504800
5	32	1505320
5	36	1505360
5	48	1505480
5	64	1505640
5	72	1505720
6	30	1506300
6	36	1506360
6	48	1506480
6	56	1506560
8	30	1508300
8	40	1508400
8	48	1508480
8	56	1508560
8	64	1508640
10	26	1510260
10	28	1510280
10	30	1510300
10	36	1510360
10	40	1510400
10	48	1510480
10	56	1510560
10	60	1510600
10	64	1510640
10	72	1510720
12	30	1512300
12	32	1512320
12	48	1512480
12	56	1512560
12	64	1512640
7/32	32	1514320
9/32	32	1518320
<b>1" O.D. Price \$6.45</b>		
10	36	1510361
10	40	1510401
12	32	1512322
12	40	1512400
7/32	32	1514321
1/4	16	1516161
1/4	18	1516181
1/4	22	1516221
1/4	24	1516241
1/4	26	1516261
1/4	27	1516271
1/4	30	1516301
1/4	32	1516321
1/4	36	1516361
1/4	40	1516401
1/4	48	1516481
1/4	56	1516561
1/4	64	1516641

Size	Threads Per Inch	Order No.
<b>1" O.D. (Cont'd) Price</b>		
1/4	72	1516721
1/4	80	1516801
5/16	16	1520161
5/16	20	1520201
5/16	22	1520221
5/16	27	1520271
5/16	28	1520281
5/16	30	1520301
5/16	32	1520321
5/16	36	1520361
5/16	40	1520401
5/16	48	1520481
5/16	56	1520561
3/8	14	1524141
3/8	18	1524181
3/8	20	1524201
3/8	26	1524261
3/8	27	1524271
3/8	28	1524281
3/8	30	1524301
3/8	32	1524321
3/8	36	1524361
3/8	40	1524401
3/8	48	1524481
7/16	12	1528121
7/16	18	1528181
7/16	24	1528241
7/16	27	1528271
7/16	28	1528281
7/16	30	1528301
7/16	32	1528321
7/16	36	1528361
7/16	40	1528401
7/16	48	1528481
7/16	56	1528561
1/2	12	1532121
1/2	24	1532241
1/2	27	1532271
1/2	28	1532281
1/2	32	1532321
1/2	40	1532401
1/2	48	1532481
1/2	56	1532561
<b>1-1/2" O.D. Price</b>		
1/4	24	1516242
1/4	27	1516272
1/4	32	1516322
5/16	32	1520322
3/8	20	1524202
3/8	32	1524322
3/8	40	1524402
15/32	32	1530322
1/2	12	1532122
1/2	14	1532142
1/2	16	1532162
1/2	18	1532182
1/2	24	1532242
1/2	26	1532262
1/2	27	1532272
1/2	28	1532282
1/2	30	1532302
1/2	32	1532322

(Continued)

CUTTING TOOLS - TAPS & DIES

HIGH SPEED STEEL / SCREW ADJUSTABLE

## SPECIAL THREAD ROUND SPLIT DIES

SERIES 13:



H.S.S /  
SCREW ADJUSTABLE



## LEFT HAND ROUND SPLIT DIES

SERIES 15:



(Continued)

Size	Threads Per Inch	Order No.
<b>1-1/2" O.D. Price</b>		
1/2	36	1532362
1/2	40	1532402
1/2	48	1532482
1/2	56	1532562
9/16	14	1536142
9/16	16	1536162
9/16	20	1536202
9/16	24	1536242
9/16	27	1536272
9/16	28	1536282
9/16	32	1536322
9/16	36	1536362
9/16	40	1536402
9/16	48	1536482
5/8	10	1540102
5/8	12	1540122
5/8	14	1540142
5/8	16	1540162
5/8	20	1540202
5/8	24	1540242
5/8	27	1540272
5/8	28	1540282
5/8	32	1540322
5/8	36	1540362
5/8	40	1540402
5/8	48	1540482
5/8	56	1540562
5/8	64	1540642
11/16	12	1544122
11/16	14	1544142
11/16	18	1544182
11/16	20	1544202
11/16	24	1544242
11/16	27	1544272
11/16	32	1544322
11/16	36	1544362
11/16	40	1544402
3/4	12	1548122
3/4	14	1548142
3/4	18	1548182
3/4	20	1548202
3/4	24	1548242
3/4	27	1548272
3/4	28	1548282
3/4	30	1548302
3/4	32	1548322
3/4	36	1548362
3/4	40	1548402
3/4	48	1548482
3/4	56	1548562
<b>2" O.D. Price</b>		
3/4	18	1548183
3/4	20	1548203
13/16	10	1552103
13/16	12	1552123
13/16	14	1552143
13/16	16	1552163

Size	Threads Per Inch	Order No.
<b>2" O.D. (Cont'd) Price</b>		
13/16	18	1552183
13/16	20	1552203
13/16	24	1552243
13/16	28	1552283
13/16	32	1552323
7/8	10	1556103
7/8	12	1556123
7/8	16	1556163
7/8	18	1556183
7/8	20	1556203
7/8	24	1556243
7/8	27	1556273
7/8	28	1556283
7/8	32	1556323
7/8	36	1556363
7/8	40	1556403
7/8	48	1556483
15/16	9	1560093
15/16	10	1560103
15/16	12	1560123
15/16	16	1560163
15/16	18	1560183
15/16	20	1560203
15/16	24	1560243
15/16	27	1560273
15/16	32	1560323
1	10	1564103
1	16	1564163
1	18	1564183
1	20	1564203
1	24	1564243
1	27	1564273
1	28	1564283
1	32	1564323
1	36	1564363
1	40	1564403
1	48	1564483
1	56	1564563
1-1/16	12	1568123
1-1/16	14	1568143
1-1/16	16	1568163
1-1/16	18	1568183
1-1/16	20	1568203
<b>2-1/2" O.D. Price</b>		
1-1/16	10	1568104
1-1/16	12	1568124
1-1/16	16	1568164
1-1/16	20	1568204
1-1/8	8	1572084
1-1/8	10	1572104
1-1/8	16	1572164
1-1/8	18	1572184
1-1/8	20	1572204
1-3/16	12	1576124
1-3/16	18	1576184
1-1/4	8	1580084
1-1/4	16	1580164
1-1/4	18	1580184
1-1/4	20	1580204
1-1/4	32	1580324
1-5/16	12	1584124
1-5/16	16	1584164
1-3/8	8	1588084
1-3/8	16	1588164
1-3/8	18	1588184
1-3/8	24	1588244
1-1/2	8	1596084
1-1/2	16	1596164

Size	Threads Per Inch	Order No.
<b>3" O.D. Price</b>		
1-9/16	18	5136185
1-9/16	20	5136205
1-5/8	8	5140085
1-11/16	18	5144185
1-3/4	5	5148053
1-3/4	8	5148085
1-3/4	10	5148105
1-3/4	12	5148125
1-3/4	20	5148205
1-7/8	5	5156055
1-7/8	8	5156085
2	4-1/2	5200045
2	8	5200085
2	16	5200165
2	20	5200205
<b>4" O.D. Price</b>		
2	12	5200126
2-1/8	18	5208186
2-1/4	4-1/2	5216046
2-1/4	12	5216126
2-1/4	16	5216166
2-1/2	4	5232046
2-1/2	8	5232086
2-1/2	12	5232126
<b>5" O.D. Price</b>		
2-5/8	12	5240127
2-5/8	16	5240167
2-3/4	8	5248087
2-3/4	12	5248127
3-1/4	12	5316127
3-1/2	12	5332127

H.S.S /  
SCREW ADJUSTABLE



## LEFT HAND ROUND SPLIT DIES - METRIC SIZES

SERIES 15:



Size	Pitch	Order No.
mm	mm	
<b>1" O.D. Price</b>		
3.0	.50	2251211
4.0	.70	0151501
5.0	.80	0151801
6.0	1.00	0152101
7.0	1.00	0152301
8.0	1.25	0152501
10.0	1.50	0152851
<b>1-1/2" O.D. Price</b>		
12.0	1.75	0153852
14.0	2.00	0154152
16.0	1.50	0154352
16.0	2.00	0154452
18.0	1.00	0154552
18.0	1.50	0154602

Size	Threads Per Inch	Order No.
<b>13/16" O.D. Price</b>		
0	80	2500800
1	64	2501640
1	72	2501720
2	56	2502560
2	64	2502640
3	48	2503480
3	56	2503560
4	40	2504400
4	48	2504480
5	40	2505400
5	44	2505440
6	32	2506320
6	40	2506400
8	32	2508320
8	36	2508360
10	24	2510240
10	32	2510320
12	24	2512240
12	28	2512280
<b>1" O.D. Price</b>		
5	40	2505401
6	32	2506321
8	32	2508321
10	24	2510241
10	32	2510321
1/4	20	2516201
1/4	28	2516281
5/16	18	2520181
5/16	24	2520241
3/8	16	2524161
3/8	24	2524241
7/16	14	2528141
7/16	20	2528201
1/2	13	2532131
1/2	20	2532201
<b>1-1/2" O.D. Price</b>		
1/4	20	2516202
1/4	28	2516282
5/16	18	2520182
5/16	24	2520242
3/8	16	2524162
1/2	13	2532132
1/2	20	2532202
9/16	12	2536122
9/16	18	2536182
5/8	11	2540112
5/8	18	2540182
3/4	10	2548102
3/4	16	2548162
<b>2" O.D. Price</b>		
3/4	10	2548103
3/4	16	2548163
7/8	9	2556093
7/8	14	2556143
1	8	2564083
1	12	2564123
1	14	2564143

For larger diameters; please inquire.



**HIGH SPEED STEEL /  
SCREW ADJUSTABLE  
METRIC ROUND  
SPLIT DIES  
SERIES 17:**



Dia mm	Pitch mm	Order No.
<b>13/16" O.D. Price</b>		
1.0	.25	1250050
1.6	.35	1250100
2.0	.40	1250150
2.5	.45	1250200
4.0	.50	1250340
4.0	.70	1251500
4.0	.75	1250350
5.0	.80	1251800
<b>1" O.D. Price</b>		
1.0	.20	1250051
1.0	.25	1250101
1.2	.20	1250151
1.2	.25	1250201
1.4	.20	1250251
1.4	.30	1250301
1.5	.30	1250351
1.5	.35	1250401
1.6	.35	1250451
1.7	.20	1250501
1.7	.35	1250551
1.8	.35	1250601
2.0	.25	1250651
2.0	.40	1250701
2.0	.45	1250751
2.0	.50	1250801
2.2	.45	1250851
2.3	.25	1250901
2.3	.40	1250951
2.3	.45	1250971
2.5	.45	1251001
2.6	.35	1251051
2.6	.45	1251101
3.0	.35	1251151
3.0	.50	1251201
3.0	.60	1251251
3.0	.75	1251301
3.5	.35	1251351
3.5	.50	1251361
3.5	.60	1251401
4.0	.50	1251451
4.0	.70	1251501
4.0	.75	1251551
4.5	.50	1251601
4.5	.75	1251651
5.0	.50	1251701
5.0	.75	1251751
5.0	.80	1251801
5.0	.90	1251851
5.0	1.00	1251871
5.5	.70	1251901
5.5	.90	1251951
6.0	.50	1252001
6.0	.75	1252051
6.0	1.00	1252101
6.0	1.25	1252151
6.3	1.00	1252171
7.0	.50	1252201
7.0	.75	1252251
7.0	1.00	1252301
7.0	1.25	1252351
8.0	.75	1252401
8.0	1.00	1252451

Dia mm	Pitch mm	Order No.
<b>1" O.D. (Cont'd) Price</b>		
8.0	1.25	1252501
9.0	.75	1252551
9.0	1.00	1252601
9.0	1.25	1252651
10.0	.75	1252701
10.0	1.00	1252751
10.0	1.25	1252801
10.0	1.50	1252851
11.0	.75	1252901
11.0	1.00	1252951
11.0	1.25	1253001
11.0	1.50	1253051
12.0	1.00	1253101
12.0	1.25	1253151
12.0	1.50	1253201
12.0	1.75	1253251
<b>1-1/2" O.D. Price</b>		
8.0	1.25	1252502
9.0	1.00	1253302
9.0	1.25	1253352
10.0	.75	1253402
10.0	1.00	1253452
10.0	1.25	1253502
10.0	1.50	1253552
11.0	1.00	1253602
11.0	1.25	1253603
11.0	1.50	1253652
12.0	1.00	1253702
12.0	1.25	1253752
12.0	1.50	1253802
12.0	1.75	1253852
13.0	1.00	1253822
13.0	1.50	1253902
14.0	.50	1253950
14.0	1.00	1253952
14.0	1.25	1254002
14.0	1.50	1254052
14.0	1.75	1254102
14.0	2.00	1254152
15.0	1.00	1254182
15.0	1.25	1254192
15.0	1.50	1254202
16.0	1.00	1254252
16.0	1.25	1254302
16.0	1.50	1254352
16.0	1.75	1254402
16.0	2.00	1254452
17.0	1.00	1254472
17.0	1.25	1254482
17.0	1.50	1254502
18.0	1.00	1254552
18.0	1.50	1254602
18.0	2.00	1254652
18.0	2.50	1254702
19.0	1.50	1254782
20.0	1.00	1254712
20.0	1.50	1254722
20.0	2.00	1254852
20.0	2.50	1254732
<b>2" O.D. Price</b>		
18.0	2.00	1254653
18.0	2.50	1254743
19.0	1.50	1254783
20.0	1.25	1254753
20.0	1.50	1254803
20.0	2.00	1254853
20.0	2.50	1254903
22.0	1.00	1254953
22.0	1.50	1255003
22.0	2.00	1255053
22.0	2.50	1255103
24.0	1.00	1255143
24.0	1.50	1255153

Dia mm	Pitch mm	Order No.
<b>2" O.D. (Cont'd) Price</b>		
24.0	2.00	1255203
24.0	3.00	1255253
25.0	1.50	1255353
26.0	1.00	1255443
26.0	1.50	1255263
27.0	2.00	1255273
27.0	3.00	1255283
28.0	1.50	1255293
30.0	1.50	1255303
30.0	2.00	1255313
30.0	3.50	1255323
<b>2-1/2" O.D. Price</b>		
25.0	1.00	1255304
25.0	1.50	1255354
25.0	2.50	1255404
26.0	1.50	1255454
27.0	1.00	1255504
27.0	1.50	1255554
27.0	2.00	1255604
27.0	3.00	1255654
28.0	1.00	1255704

Dia mm	Pitch mm	Order No.
<b>2-1/2" OD (Cont'd) Price</b>		
28.0	1.25	1255744
28.0	1.50	1255754
28.0	2.00	1255804
29.0	1.50	1255824
30.0	1.50	1255854
30.0	2.00	1255904
30.0	3.50	1255954
32.0	1.50	1256323
33.0	2.00	1255964
33.0	3.50	1256338
34.0	1.50	1256343
35.0	1.50	1256353
36.0	1.50	1253653
36.0	3.00	1256366
36.0	4.00	1256368
<b>3" O.D. Price</b>		
42.0	4.50	1256005
45.0	1.50	1256453
45.0	4.50	1256055
48.0	5.00	1256105
50	1.50	387624

**HIGH SPEED STEEL /  
SCREW ADJUSTABLE**



**PIPE SIZE ROUND  
SPLIT DIES  
SERIES 14:**

Left Hand available. See our website or inquire.

Size	Threads Per Inch	Order No.	
		N.P.T.	N.P.S.
<b>1" O.D. Price</b>			
1/16	27	2000041	2010041
1/8	27	2000081	2010081
<b>1-1/2" O.D. Price</b>			
1/8	27	2000082	2010082
1/4	18	2000162	2010162
3/8	18	2000242	2010242
1/2	14	2002322	-
<b>2" O.D. Price</b>			
1/4	18	2000163	2010163
3/8	18	2000243	2010243
1/2	14	2000323	2010323
3/4	14	2000483	2010483
<b>2-1/2" O.D. Price</b>			
3/4	14	9380146	-
1	11-1/2	2000644	2010644
<b>3" O.D. Price:</b>			
1-1/4	11-1/2	2000805	2010805
1-1/2	11-1/2	2000965	380249
<b>3-1/2" O.D. Price</b>			
1-1/2	11-1/2	2000966	2010966
<b>4" O.D. Price</b>			
1-1/2	11-1/2	9000967	2010967
2	11-1/2	9002007	380250
2-1/2	11-1/2	380151	380251
<b>5" O.D. Price</b>			
2-1/2	8	2002328	2012328
3	8	2003008	2013005

**CUTTING TOOLS - TAPS & DIES**

HIGH SPEED STEEL / SCREW ADJUSTABLE

## BRITISH PIPE DIES

SERIES 943:



Size	Threads Per Inch	Outside Dia.	BSPF		BSPT	
			Order No.	Price	Order No.	Price
1/8	28	1	9432081		9433081	
1/8	28	1-1/2	9432082		9433082	
1/4	19	1-1/2	9432162		9433162	
3/8	19	1-1/2	9432242		9433242	
1/2	14	1-1/2	9432322		9433322	
1/4	19	2	9432163		9433163	
3/8	19	2	9432243		9433243	
1/2	14	2	9432325		9433323	
5/8	14	2	9432403		9433403	
3/4	14	2	9432483		9433483	



HIGH SPEED STEEL / SCREW ADJUSTABLE

## BSW DIES

SERIES 943:



Size	Threads Per inch	Outside Dia.	Order No.	Price
1/4	20	1"	4316201	
5/16	18	1"	4320181	
3/8	16	1"	4324161	
7/16	14	1-1/2"	4328142	
1/2	12	1-1/2"	4332122	
9/16	12	1-1/2"	4336122	
5/8	11	1-1/2"	4340112	
3/4	10	1-1/2"	4348102	
7/8	9	2"	4356093	
1	8	2"	4364083	



HIGH SPEED STEEL / SCREW ADJUSTABLE

## ROUND ADJUSTABLE DIES

MACHINE SCREW, FRACTIONAL

SERIES 842:



HIGH SPEED STEEL / SCREW ADJUSTABLE

## BSC DIES

SERIES 943:



Size	Threads Per Inch	Outside Dia.	Order No.	Price
1/4	26	1"	9432716	
5/16	26	1"	9432720	
3/8	26	1"	9432724	
7/16	26	1"	9432728	
1/2	26	1"	9432732	



Size	Threads Per Inch	Order No.
<b>13/16" O.D. Price</b>		
5	40	400013
5	44	400021
6	32	400039
6	40	400047
8	32	400054
8	36	400062
10	24	400070
10	32	400088
12	24	400096
12	28	400104
1/4	20	400211
1/4	28	400229
5/16	18	400237
5/16	24	400245
<b>1" O.D. Price</b>		
6	32	400138
10	24	400179
10	32	400187
12	24	400195
1/4	20	400302
1/4	28	400310
5/16	18	400328
5/16	24	400336
3/8	16	400344
3/8	24	400351
7/16	14	400369
7/16	20	400377

Size	Threads Per Inch	Order No.
<b>1-1/2" O.D. Price</b>		
1/4	20	400401
1/4	28	400419
5/16	18	400427
5/16	24	400435
3/8	16	400443
3/8	20	400450
7/16	14	400468
7/16	20	400476
1/2	13	400484
1/2	20	400492
9/16	12	9999500
9/16	18	400518
5/8	11	400526
5/8	18	400534
<b>2" O.D. Price</b>		
5/8	11	400609
5/8	18	400617
3/4	10	400625
3/4	16	400633
7/8	9	400641
7/8	14	400658

HIGH SPEED STEEL / SCREW ADJUSTABLE

## BSF - DIES

SERIES 943:



Size	Threads Per Inch	Outside Dia.	Order No.	Price
3/16	32	1"	4312321	
1/4	26	1	4316261	
5/16	22	1	4320221	
3/8	20	1	4324201	
7/16	18	1	4328181	
1/2	16	1	4332161	



## ROUND DIE STOCK HANDLES

SERIES 405:



- For holding adjustable round split dies.
- Three set screw pattern.
- Black finish.
- Single piece construction.

Order No.	Outside Dia. of Die Inch	Length	Price
2320058	5/8	5-1/2	
2320000	13/16	6-1/2	
2320010	1	8-1/2	
2320012	1-5/16	10	
2320015	1-1/2	12	
2320020	2	15	
2320025	2-1/2	19	
2320030	3	22	
2320035	3-1/2	24	
2320040	4	29	
2320050	5	33	
2321400	4pc Set consisting of 13/16", 1", 1-1/2", 2" die handles.		



## DIE HOLDERS

SERIES 406:



For round dies ranging from #0 through 3/4. Suitable for short or medium run threading of shafts on lathes, milling machines, tapping attachments, etc. Overall length : 3".

O.D. of Die	Shank Dia.	Order No.	Price
13/16	1/2"	2325000	
1	1/2"	2325010	
1-1/2	3/4"	2325015	

CARBON STEEL

**HEXAGON RETHREADING DIES**

SERIES 16: RIGHT HAND, SUPERIOR IMPORT  
 SERIES 798: RIGHT HAND, MADE IN U.S.A.  
 SERIES 835: LEFT HAND, SUPERIOR IMPORT



For rethreading, damaged, jammed or rusty threads.  
 No special holder is required for these dies. Any wrench large enough will suffice.

Size	Threads Per Inch	MEDA RH		STAR USA RH		MEDA LH	
		Order No.	Price	Order No.	Price	Order No.	Price
2	56	1200256		-		-	
4	36	1200436		-		-	
4	40	1200440		-		-	
4	48	1200448		-		-	
5	40	1200540		-		-	
5	44	1200544		-		-	
6	32	1200632		6500632		-	
6	40	1200640		6500640		-	
8	32	1200832		6500832		-	
8	36	1200836		6500836		-	
10	24	1201024		6501024		-	
10	32	1201032		6501032		-	
12	24	1201224		6501224		-	
12	28	1201228		6501228		-	
1/4	20	1201620		6501620		8351620	
1/4	28	1201628		6501628		8351628	
5/16	18	1202018		6502018		8352018	
5/16	24	1202024		6502024		8352024	
3/8	16	1202416		6502416		8352416	
3/8	24	1202424		6502424		8352424	
7/16	14	1202814		6502814		8352814	
7/16	20	1202820		6502820		8352820	
1/2	13	1203213		6503213		8353213	
1/2	20	1203220		6503220		8353220	
9/16	12	1203612		6503612		8353612	
9/16	18	1203618		6503618		8353618	
5/8	11	1204011		6504011		8354011	
5/8	18	1204018		6504018		8354018	
11/16	11	1204411		6504411		8354411	
11/16	16	1204416		6504416		8354416	
3/4	10	1204810		6504810		8354810	
3/4	16	1204816		6504816		8354816	
7/8	9	1205609		6505609		9355609	
7/8	14	1205614		6505614		8355614	
1	8	1206408		6506408		8356408	
1	12	1206412		6506412		8356412	
1	14	1206414		6506414		8356414	
1-1/8	7	1207207		-		8357207	
1-1/8	12	1207212		-		8357212	
1-1/4	7	1208007		-		8358007	
1-1/4	12	1208012		-		8358012	
1-3/8	6	1208806		-		8358806	
1-3/8	12	1208812		-		8358812	
1-1/2	6	1209606		-		8359606	
1-1/2	12	1209612		-		8359612	

HIGH SPEED STEEL

**RETHREADING DIES**

SERIES 765:



Threading Dies are designed for tough cutting applications of all types of external threads, such as threading rods, bolts and studs.

Sizes	Pitch	Order No.	Price Each
1/4	20	6511620	
1/4	28	6511628	
5/16	18	6512018	
5/16	24	6512024	
3/8	16	6512416	
3/8	24	6512424	
7/16	14	6512814	
7/16	20	6512820	
1/2	13	6513213	
1/2	20	6513220	
9/16	12	6513612	
9/16	18	6513618	
5/8	11	6514011	
5/8	18	6514018	
3/4	10	6514810	
3/4	16	6514816	
7/8	9	6515609	
7/8	14	6515614	
1	8	6516408	
1	12	6516412	
1	14	6516414	
1-1/8	7	6517207	
1-1/8	12	6517212	
1-1/4	7	6518007	
1-1/4	12	6518012	
1-3/8	6	6518806	
1-3/8	12	6518812	
1-1/2	6	6519606	
1-1/2	12	6519612	

CARBON STEEL

**HEXAGON RETHREADING DIES - METRIC SIZES**

SERIES 834:



Size	T.P.I	Order No.	Price
3.0	.50	8340350	
3.0	.60	8340360	
3.5	.60	8340361	
4.0	.70	8340470	
5.0	.80	8340580	
6.0	1.00	8340610	
7.0	1.00	8340710	
8.0	1.00	8340810	
8.0	1.25	8340812	
9.0	1.25	8340912	

Size	T.P.I	Order No.	Price
10.0	1.00	8341010	
10.0	1.25	8341012	
10.0	1.50	8341015	
12.0	1.25	8341212	
12.0	1.50	8341215	
12.0	1.75	8341217	
14.0	1.25	8341412	
14.0	1.50	8341415	
14.0	2.00	8341420	

Size	T.P.I	Order No.	Price
16.0	1.00	8341610	
16.0	1.50	8341615	
16.0	2.00	8341620	
18.0	1.50	8341815	
18.0	2.50	8341825	
20.0	2.50	8342025	
22.0	1.50	8342215	
24.0	1.50	8342415	

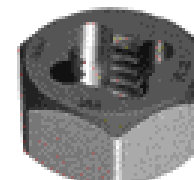

CUTTING TOOLS - TAPS & DIES

CARBON STEEL

## HEXAGON RETHREADING DIES



CARBON STEEL

## HEXAGON DIE SETS



Use with any type of wrench for rethreading bruised, rusty or worn threads.

SERIES 16:



CUTTING TOOLS - TAPS & DIES

### SPECIAL THREAD

SERIES 455 :

Size	Threads Per Inch	Order No.	Price
1-1/8	8	1207208	
1-1/4	8	1208008	
1-3/8	8	1208808	
1-1/2	8	1209608	
1-5/8	5-1/2	1214005	
1-5/8	8	1214008	
1-5/8	12	1214012	
1-3/4	5	1214805	
1-3/4	8	1214808	
1-3/4	12	1214812	
1-3/4	20	1214820	
1-7/8	5	1215605	
1-7/8	8	1215608	
1-7/8	12	1215612	
2	4-1/2	1220004	
2	8	1220008	
2	12	1220012	
2-1/8	8	1220808	
2-1/8	12	1220812	
2-1/4	4-1/2	1221604	
2-1/4	8	1221608	
2-1/4	12	1221612	
2-3/8	8	1222408	
2-3/8	12	1222412	
2-1/2	4	1223204	
2-1/2	8	1223208	
2-1/2	12	1223212	
2-5/8	8	1224008	
2-5/8	12	1224012	
2-3/4	4	395440	
2-3/4	8	1224808	
2-3/4	12	1224812	
2-7/8	8	1225608	
2-7/8	12	1225612	
3	8	1230080	
3	12	1230021	
3-1/4	4	395520	
3-1/4	8	1231608	
3-1/4	12	1231612	
3-1/2	4	395560	
3-1/2	8	1233208	
3-1/2	12	1233212	
3-3/4	4	395600	
4	4	395640	
4	8	1240008	
4	12	1240012	

Many more sizes available. See our website or inquire.



Includes	Range	Order No.	Price
1/4-20, 5/16-18, 3/8-16, 7/16-14, 1/2-13, 9/16-12, 5/8-11, 3/4-10, 7/8-9, 1-8	1/4" to 1" NC 10pc	Right Hand 1616641 Left Hand 1616642	
1/4-28, 5/16-24, 3/8-24, 7/16-20, 1/2-20, 9/16-18, 5/8-18, 3/4-16, 7/8-14, 1-14	1/4" to 1" NF 10pc	Right Hand 1616643 Left Hand 1616644	
Supplied with stand. 1 each die as listed above. 20 dies covering the whole range course and fine 1/4" to 1".	1/4" to 1" NC & NF 20pc	395992	
5.0 x 0.8, 5.0 x 0.9, 6.0 x 1.0, 6.0 x 0.75, 8.0 x 1.25, 8.0 x 1.0, 10.0 x 1.5, 10.0 x 1.25, 12.0 x 1.75, 12.0 x 1.50, 14.0 x 2.0, 14.0 x 1.50, 16.0 x 2.0, 16.0 x 1.50, 18.0 x 2.50, 18.0 x 2.0, 20.0 x 2.5, 20.0 x 2.0, 24.0 x 3.0, 24.0 x 2.0	5mm - 24mm 20pc	395993	
1/8" - 27NPT, 1/4" - 8NPT, 3/8" - 18NPT, 1/2" - 14NPT, 3/4" - 14NPT, 1" - 11-1/2NPT.	1/8" to 1" NPT 12pc	395994	
Includes 1 each die & tap.			

### LEFT HAND

SERIES 835:

Size	Threads Per Inch	Order No.	Price
1/4	20	8351620	
1/4	28	8351628	
5/16	18	8352018	
5/16	24	8352024	
3/8	16	8352416	
3/8	24	8352424	
7/16	14	8352814	
7/16	20	8352820	
1/2	13	8353213	
1/2	20	8353220	
5/8	11	8354011	
5/8	18	8354018	
3/4	10	8354810	
3/4	16	8354816	
7/8	9	9355609	
7/8	14	8355614	
1	8	8356408	
1	12	8356412	
1	14	8356414	

### HEXAGON DIE ADAPTOR

SERIES 712:



Converts round dies to hexagon dies when space limitations rule out use of diestocks.

Round Die O.D.	Order No.	Price
13/16	7120000	
1	7120010	
1-1/2	7120015	
2	7120020	
2-1/2	7120025	
3	7120030	

### PIPE SIZE (NPT)

SERIES 456:

Size	Threads Per Inch	Order No.	Price
1/8	27	2540008	
1/4	18	2540016	
3/8	18	2540024	
1/2	14	2540032	
3/4	14	2540048	
1	11-1/2	2540064	
1-1/4	11-1/2	2540080	
1-1/2	11-1/2	2540096	

**T-HANDLE TAP WRENCHES**  
SERIES 407:



Usable for small drills and reamers.  
Hardened and tempered jaws.

Tap Capacity	Square Size (mm)	Order No.	Price
#0-6, 1/16-5/32	2.5 - 3.4	2330001	
#7-14, 5/32-1/4	3.0 - 5.0	2330002	
1/4-1/2	5.0 - 7.0	2330003	
3 Piece Set		2331612	

**EXTRA LONG TAP WRENCHES**  
SERIES 407:

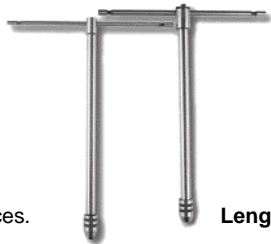

The long shank permits tapping in hard to get at places.

Length : 13"

Tap Capacity	Square Size (mm)	Type	Order No.	Price
#7-14, 5/32-1/4	3.0 - 5.0	Plain	2335512	
1/4-1/2	5.0 - 7.0	Plain	2335523	
#7-14, 5/32-1/4	3.0 - 5.0	Ratchet	2335212	
1/4-1/2	5.0 - 7.0	Ratchet	2340212	

**MINI TAP WRENCHES**  
SERIES 407:



Ideal tapping tools, for small job applications.

Order No.	Tap Capacity Inch	Price
2330014	1/4"	
2330012	1/2"	
2331412	2 Piece Set	

**STRAIGHT TAP WRENCHES**  
SERIES 409:



Precision made with hardened jaws.



Model No.	Hand Taps	Machine Screw Taps	Capacity		Lgth.	Order No.	Price
			Pipe Taps	Hand Reamers			
TW0	1/16 - 1/4	#0-14		1/8 - 21/64	7	2340000	
TW4	1/16 - 3/8	#0-14		1/8 - 25/64	9	2340040	
TW5	5/32 - 1/2	#7-14	1/8	11/64 - 7/16	11	2340050	
TW6	5/32 - 3/4	#7-14	1/8 - 1/4	11/64 - 41/64	15	2340060	
TW7	1/4 - 1-1/8		1/8 - 3/4	9/32 - 29/32	19	2340070	
TW7-1/2	1/2 - 1-3/8		1/8 - 1	3/4 - 1-5/32	31	2340075	
TW8	3/4 - 1-1/2		3/8 - 1-1/4	37/64 - 1-11/32	40	2340080	
TW22	1 - 2-1/2		3/4 - 2	7/8 - 2-1/8	54	2340220	
3 Piece Set - TW0, TW4, TW5						4090000	

**T-HANDLE RATCHET TAP WRENCHES**  
SERIES 407:



For right and left hand tapping.

Also usable for small drills and reamers.

Hardened and tempered jaws.

Tap Capacity	Square Size (mm)	Order No.	Price
#0-6, 1/16-5/32	2.5 - 3.4	2335001	
#7-14, 5/32-1/4	3.0 - 5.0	2335002	
1/4-1/2	5.0 - 7.0	2335003	
3 Piece Set		2335004	

**T-HANDLE TAP WRENCHES**  
STARRETT SERIES 93:



- For holding taps, drills, reamers and small tools to be turned by hand.
- Body is centered for use on lathe centers or drilling machines to start tap straight.
- Wrenches have sliding handle for positioning and leverage convenience.
- Jaws conform to the tool being held, and are heat treated to withstand heavy use.



Capacity				Body Lgth.		Cat. No.	EDP No.	Price
Tap Size		Square Shank		Inch	mm			
Inch	mm	Inch	mm					
1/16-3/16"	1.6-4.7	1/16-5/32"	1.6-4	2"	50	93A	50427	
7/32-7/16"	5.5-11	5/32-1/4"	4-6.4	2 1/2"	63	93B	50428	
1/4-1/2"	6.4-12.7	3/16-5/16"	4.7-8	3 1/2"	88	93C	50429	
1/16-3/16"	1.6-4.7	1/16-5/32"	1.6-4	6"	150	93D	50430	
7/32-7/16"	5.5-11	5/32-1/4"	4-6.4	10"	250	93E	50431	
1/4-1/2"	6.4-12.7	3/16-5/16"	4.7-8	13"	330	93F	50432	

### TAP WRENCHES

STARRETT SERIES 91:

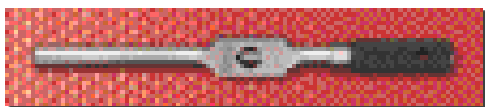

- Made of rugged steel, well proportioned and easy to handle.
- Tempered gripping surfaces firmly hold square or round shanks.
- Plunger, operated by the knurled sleeve, backs off the instant pressure is removed from the sleeve.

Capacity				Body Lgth.		Cat. No.	EDP No.	Price
Tap Size		Square Shank		Inch	mm			
Inch	mm	Inch	mm	Inch	mm			
1/16-1/4"	1.6-6.4	3/32-5/32"	2.4-4	6"	150	91A	50419	
3/16-1/2"	4.7-12.7	5/32-9/32"	4-7	9"	225	91B	50420	
1/4-5/8"	4.7-16	5/32-3/8"	4-9.5	12"	300	91C	50421	
5/16-3/4"	8-19	13/64-7/16"	5.2-11	16"	400	91D	50422	

### TAP WRENCH

STARRETT SERIES 174:

Ideal for holding smaller diameter taps, drills, reamers, and other tools up to 1/4" (6.35mm) in diameter.

It will firmly grip round or square shanks. The gripping surface is properly heat treated to withstand any ordinary use.

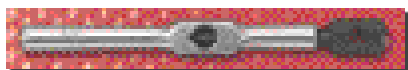

Tap Size	Capacity Shank		Body Lgth.		No.	Cat. No.	EDP Price
	Inch	mm	Inch	mm			
#0-14	1/4" Dia.	6.35	3-5/8"	90	174	50658	

### PILOTED SPINDLE TAP WRENCHES

SERIES 407:

- Tapping accessory for drill presses, lathes etc.
- For manually threading a drilled hole at one machine location without moving work.
- Hardened and tempered jaws.



Tap Capacity	Square Size (mm)	Order No.	Price
#0-14, 1/16-1/4	3.0 - 5.0	2335012	
1/4-1/2	5.0 - 7.0	2335023	
2 Piece Set		2335013	

### TAP ALIGNER

SERIES 410:

Also suitable for hand reamers. Tap wrench with hardened jaws is aligned in a slip fit guide which automatically squares the tap or reamer with the work piece.

Two sets of jaws cover a range of hand taps from #0 through 1/2". "V" on base of the guide for round parts.

Stem of tap wrench is center drilled for floating center. Complete with tap wrench, guide, and two sets of jaws.



Order No. 2345000	Price	
-------------------	-------	--

### TAP EXTENSIONS

SERIES 410:



For use with a tap wrench to permit tapping in hard to get at places.

Length	Tap Capacity	Square Size (mm)	Order No.	Price
7"/180mm	#0-14, 1/16-1/4	3.0-5.0	4100012	
10-3/4"/275mm	1/4-1/2	5.0-7.0	4100023	
2 Piece Set			4100013	

### TAP GUIDE

SERIES 410:



- Knurled for easy handling.
- 1/2" Dia. hardened shank
- 3/16" Dia. hardened tension pin
- Adjustable tension spring
- Reversible tension pin for male & female hole centering of tap
- With this tool you start every tap straight.

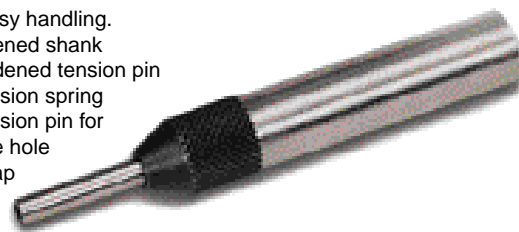

Order No. 4100000	Price	
-------------------	-------	--

### TAP GUIDE - MACHINE TYPE

SERIES 410:



- Provides sensitive feel for hand-tapping small holes on milling machines, drill presses and lathes.
- Starts every hole straight and prevents tap breakage.
- Shank Dia. 3/8", Handle Dia. 1"
- 0 to No. 12 Tap Capacity.



Order No. 4100296	Price	
-------------------	-------	--

### TAP GUIDE - SPRING CENTER

SERIES 410:



- Spring center is made of precise ground alloy steel.
- Point hardened to 50-55 HRC.
- For execution the center's body is to be gripped in a drill chuck or collet while hardened point is inserted into the center of the tapping handle.
- The stroke of center will follow the tap assuring straight and accurate hand tapped threads.
- One universal size for all tapping applications.



Order No. 4100001	Price	
-------------------	-------	--

**TAP EXTRACTORS**  
SERIES 4:



Removes broken taps quickly without injury to the thread. Extractor fingers fit into flutes of broken tap and a few turns of a tap wrench removes broken tap.

**TAP EXTRACTOR SETS**  
SERIES 4:



Tap Extractor Size		Complete Tap Extractors				Price
		Order No.				
Inch	mm	6 Flute	4 Flute	3 Flute	2 Flute	
4	3	-	-	0600043	0600042	
5 (1/8)	3.2	-	-	0600053	0600052	
6	3.5	-	0600064	0600063	0600062	
8	4	-	0600084	0600083	0600082	
10 (3/16)	5	-	0600104	0600103	0600102	
12	5.5	-	0600124	0600123	0600122	
1/4	6	-	0600164	0600163	0600162	
9/32	7	-	0600184	-	-	
5/16	7.8	-	0600204	0600203	0600202	
11/32	-	-	0600224	-	-	
3/8	9,10	-	0600244	0600243	0600242	
13/32	10	-	0600264	-	-	
7/16	11	-	0600284	0600283	0600282	
1/2	12	-	0600324	0600323	0600322	
9/16	14	-	0600364	0600363	-	
5/8	16	-	0600404	0600403	-	
11/16	18	-	0600444	-	-	
3/4	18, 20	-	0600484	0600483	-	
7/8	22	-	0600564	0600563	-	
1	25	-	0600644	0600643	-	
1-1/8	28	0600726	0600724	-	-	
1-1/4	32	0600806	0600804	-	-	
1-3/8	35	0600886	0600884	-	-	
1-1/2	38	0600966	0600964	-	-	

Sizes Included (Inch & mm)	Set No.	Order No.	Price
3/16, 1/4, 5/16, 3/8, 7/16, 1/2 5, 6, 7-8, 9-10, 11, 12	1	0620000	
1/4, 5/16, 3/8, 7/16, 1/2, 5/8 6, 7-8, 9-10, 11, 12, 16	2	0630000	
5/16, 3/8, 7/16, 1/2, 9/16, 5/8 7-8, 9-10, 11, 12, 14, 16	3	0640000	
1/8, 3/16, 1/4, 5/16, 3/8, 7/16, 1/2, 5/8, 3/4, 7/8, 1 3, 2, 5, 6, 7-8, 9-10, 11, 12, 16, 18-20, 22, 25	11	0650000	
4, 5, 6, 8, 10, 12, 1/4, 5/16, 3/8, 7/16, 1/2, 5/8, 3/4 3, 3.2, 3.5, 4, 5, 5.5, 6, 7-8, 9-10, 11, 12, 16, 18-20	13	0660000	
4, 5, 6, 8, 10, 12, 1/4, 5/16, 3/8, 7/16, 1/2, 5/8, 3/4, 7/8, 1 3, 3.2, 3.5, 4, 5, 5.5, 6, 7-8, 9-10, 11, 12, 16, 18-20, 22, 25	15	0670000	

Each set furnished in metal case. 3 Flute style supplied for sizes 6 and smaller. All other sizes supplied in 4 Flute style.

Tap Extractor Size		Extra Fingers				Price
		Order No.				
Inch	mm	6 Flute	4Flute	3 Flute	2 Flute	
4	3	-	-	0610043	0610042	
5 (1/8)	3.2	-	-	0610053	0610052	
6	3.5	-	0610064	0610063	0610062	
8	4	-	0610084	0610083	0610082	
10 (3/16)	5	-	0610104	0610103	0610102	
12	5.5	-	0610124	0610123	0610122	
1/4	6	-	0610164	0610163	0610162	
9/32	7	-	0610184	-	-	
5/16	7.8	-	0610204	0610203	0610202	
11/32	-	-	0610224	-	-	
3/8	9,10	-	0610244	0610243	0610242	
13/32	10	-	0610264	-	-	
7/16	11	-	0610284	0610283	0610282	
1/2	12	-	0610324	0610323	0610322	
9/16	14	-	0610364	0610363	-	
5/8	16	-	0610404	0610403	-	
11/16	18	-	0610444	-	-	
3/4	18, 20	-	0610484	0610483	-	
7/8	22	-	0610564	0610563	-	
1	25	-	0610644	0610643	-	
1-1/8	28	0610726	0610724	-	-	
1-1/4	32	0610806	0610804	-	-	
1-3/8	35	0610886	0610884	-	-	
1-1/2	38	0610966	0610964	-	-	

**TAP EXTRACTORS**  
SERIES 4: FOR PIPE TAPS  
(MARKED PIPE ON SLEEVE)

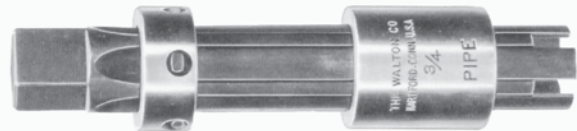

Pipe Tap Extractor Size, in.	Complete Extractor		Price	Extra Fingers		Price
	Order No.			Order No.		
	5-Flute	4-Flute		5-Flute	4-Flute	
1/8	20125	20124		22125	22124	
1/4	20255	20254		22255	22254	
3/8	20375	20374		22375	22374	
1/2	20505	9920504		22505	22504	
3/4	20755	-		22755	-	
1	9921005	-		23005	-	

Extractors specifically designed for screw thread insert (STI) taps are available. See our website or inquire.

## TAP EXTENSIONS

SERIES 4: STYLE "A" FOR HAND TAPPING ONLY



Valuable for hand tapping in awkward places where it is difficult or impossible to turn a tap wrench. Packaged and priced as a pair of identical 5" long extensions which may be used individually or together to form a 10" extension.

Tap Size	Order No.	Square Tap Shank	Square Socket Opening	Price
10 (3/16)	45010	.152	.154	
1/4	45025	.191	.193	
5/16	45031	.238	.242	
3/8	45037	.206	.210	
3/8	45038	.286	.290	
7/16	45043	.242	.246	
1/2	45050	.275	.279	
5/8	45062	.360	.364	
3/4	45075	.442	.446	
7/8	45087	.523	.527	
1	45100	.600	.604	

## TAP EXTENSIONS

SERIES 4: STYLE "B" FOR MACHINE AND HAND TAPPING

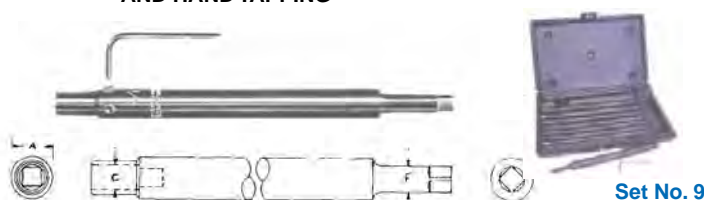

Provides easy access for hard-to-reach tapping locations. Tap is supported by close-fitting deep socket of extension and held firmly by two socket set screws which bear on the square tap shank. Standard length 8". Hex key included.

Tap Size	Order No.	A	C	F	Price
0-6 (1.6-3.5mm)	40006	5/16	.142	.255	
8 (4mm)	40008	3/8	.169	.255	
10 (3/16") (4.5-5mm)	9940010	3/8	.195	.255	
12 (5.5mm)	9940012	7/16	.221	.255	
1/4 (6mm)	9940025	7/16	.256	.381	
5/16 (7-8mm)	9940031	1/2	.319	.381	
3/8 (10mm)	9940037	5/8	.382	.367	
7/16 (11mm)	9940043	5/8	.324	.381	
1/2 (12mm)	9940050	5/8	.368	.381	
<b>Order No.: 40090</b> Set #0-1/2, 1.6 - 12mm Set of 9 extensions in case.					
9/16 (14mm)	40056	11/16	.430	.428	
5/8 (16mm)	9940062	3/4	.481	.479	
11/16 (17-18mm)	9940068	7/8	.543	.542	
3/4	9940075	7/8	.591	.589	
13/16 (20mm)	9940081	1-1/16	.653	.652	
7/8 (22mm)	40087	1-1/16	.698	.696	
15/16 (24mm)	40093	1-1/16	.764	.760	
1 (25mm)	9940100	1-1/16	.801	.799	
1-1/16 (27mm)	9940106	1-3/16	.897	.895	
1-1/8 (27mm)	40112	1-3/16	.897	.895	
1-3/16 (30mm)	9940118	1-3/8	1.022	1.020	
1-1/4 (30mm)	40125	1-3/8	1.022	1.020	
1-5/16 (33mm)	9940131	1-1/2	1.109	1.107	
1-3/8 (33mm)	40137	1-1/2	1.109	1.107	
1-7/16 (36mm)	40143	1-3/4	1.234	1.232	
1-1/2 (38mm)	40150	1-3/4	1.234	1.232	

## SCREW EXTRACTORS

SERIES 573:

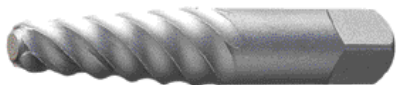

Screw Ext. No.	For Screws and Bolts Sizes	For Pipe Sizes	Size Drill To Use	OAL	MEDA		STAR USA	
					Order No.	Price	Order No.	Price
1	3/16 - 1/4		5/64	2	5730001		5730011	
2	1/4 - 5/16		7/64	2-3/8	5730002		5730022	
3	5/16 - 7/16		5/32	2-3/4	5730003		5730033	
4	7/16 - 9/16		1/4	3	5730004		5730044	
5	9/16 - 3/4	1/8 - 1/4	17/64	3-3/8	5730005		5730055	
6	3/4 - 1	3/8	13/32	3-3/4	5730006		5730066	
7	1 - 1-3/8	1/2	7/32	4-1/8	5730007		5730077	
8	1-3/8 - 1-3/4	3/4	13/16	4-3/8	5730008		5730088	
9	1-3/4 - 2-1/8	1	1-1/16	4-5/8	5730009		5730099	

## SCREW EXTRACTOR SETS

SERIES 573:



Set No.	Range	Pieces in Set	MEDA		STAR USA	
			Order No.	Price	Order No.	Price
15*	3/16 - 3/4	5	5730000		5730100	
46	7/16 - 1	3	5730406		5731406	
69	3/4 - 2-1/8	4	5730609		5731609	
19	3/16 - 2-1/8	9	5730109		5731109	

\* Supplied in plastic pouch.

## STYLE "B" FOR PIPE TAPS



Five individual extensions which fit six different sizes of pipe taps for 1/16" through 1/2" pipe.

Pipe Tap Size, In.	Order No.	Price	Pipe Tap Size, In.	Order No.	Price
1/16 & 1/8	9941006		3/8	41037	
1/8	9941012		1/2	41050	
1/4	41025				



While we show only the popular items from these companies we can supply their entire range of products. See our website or inquire.







FRACTIONAL SIZE / 40 PC. SET #4 TO 1/2" INCLUDES COARSE AND FINE THREADS		
<b>Consisting of the following sizes:</b> 1 each Tap and 1 each Round Die 4-40, 6-32, 8-32, 10-24, 10-32, 12-24, 1/4-20, 1/4-28, 5/16-18, 5/16-24, 3/8-16, 3/8-24, 7/16-14, 7/16-20, 1/2-13, 1/2-20, 9/16-12, 9/16-18, 5/8-11, 5/8-18, 3/4-10, 3/4-16, 7/8-9, 7/8-14, 1-8, 1-14, 1/8-27NPT & 1/4-18NPT		
<b>Also includes:</b> 3 Tap Wrenches, 1 Die Stock (1" O.D.) 1 Screw Pitch Gauge, 1 Screw Driver		
Description	Order No.	Price
High Speed Steel	0500040	
Carbon Steel	5210040	

METRIC SIZE / 40 PC. SET 3 TO 12mm INCLUDES COARSE AND FINE THREADS		
<b>Consisting of the following sizes:</b> 1 each Tap and 1 each Round Die 3-0.5, 3-0.6, 4-0.7, 4-0.75, 5-0.8, 5-0.9, 6-1.0, 7-1.0, 8-1.0, 8-1.25, 9-1.25, 10-1.25, 10-1.50, 11-1.50, 12-1.25, 12-1.50, 12-1.75		
<b>Also includes:</b> 3 Tap Wrenches, 1 Die Stock (1" O.D.), 1 Screw Pitch Gauge, 1 Screw Driver		
Description	Order No.	Price
High Speed Steel	0500140	
Carbon Steel	5210140	

TAP AND DIES SET 6 TO 24MM		
<b>Consisting of the following sizes:</b> 1 each plug Tap and Die 6-10, 6-0.75, 8-1.25, 8-1.0, 10-1.50, 10-1.25, 12-1.75, 12-1.5, 14-2.0, 14-1.5, 16-2.0, 16-1.5, 18-2.5, 18-1.5, 20-2.5, 20-1.5, 22-2.5, 22-1.5, 24-3.0, 24-2.0		
<b>Also includes:</b> Die Stock 1-1/2" O.D. & 2" O.D. Tap Wrench No.5 & No. 7		
Description	Order No.	Price
High Speed Steel	395973	
Carbon Steel	395930	

FRACTIONAL SIZE / 64 PC. SET #4 - 40 TO 1" INCLUDES COARSE & FINE THREADS		
<b>Consisting of the following sizes:</b> 1 each Tap and 1 each Round Die 4-40, 6-32, 8-32, 10-24, 10-32, 12-24, 1/4-20, 1/4-28, 5/16-18, 5/16-24, 3/8-16, 3/8-24, 7/16-14, 7/16-20, 1/2-13, 1/2-20, 9/16-12, 9/16-18, 5/8-11, 5/8-18, 3/4-10, 3/4-16, 7/8-9, 7/8-14, 1-8, 1-14, 1/8-27NPT & 1/4-18NPT		
<b>Outside diameter of round dies:</b> #4 to 1/2 - 1" O.D., 9/16 to 3/4 - 1-1/2" O.D., 7/8 to 1 - 2" O.D.		
<b>Also Includes:</b> 2 Straight Tap Wrenches, 1 T Handle Tap Wrench, 1 Screw Pitch Gauge, 1 Screwdriver and 3 Die Stocks: 1", 1-1/2" and 2"		
Description	Order No.	Price
High Speed Steel	0500064	
Carbon Steel	5210064	

FRACTIONAL SIZE / 45 PC. SET 1/4" TO 1" INCLUDES COARSE & FINE THREADS		
<b>Consisting of the following sizes:</b> 1 each Tap and 1 each Round Die 1/4-20, 1/4-28, 5/16-18, 5/16-24, 3/8-16, 3/8-24, 7/16-14, 7/16-20, 1/2-13, 1/2-20, 9/16-12, 9/16-18, 5/8-11, 5/8-18, 3/4-10, 3/4-16, 7/8-9, 7/8-14, 1-8, 1-14		
<b>Outside diameter of round dies:</b> 1/4 to 3/8 - 1" O.D. 7/16 to 5/8 - 1-1/2" O.D. 3/4 TO 1 - 2" O.D.		
<b>Also Includes:</b> 2 Straight Tap Wrenches and 3 Die Stocks: 1", 1-1/2" and 2"		
Description	Order No.	Price
High Speed Steel	0500045	
Carbon Steel	0395920	

FRACTIONAL & METRIC SIZES/ 60 PC. SET in plastic case. INCLUDES COARSE & FINE THREADS		
<b>Consisting of the following sizes:</b> 1 each Plug Tap and Round Die 4-40, 6-32, 8-32, 10-24, 12-24, 1/4-20, 5/16-18, 3/8-16, 7/16-14, 1/2-13, 10-32, 1/4-28, 5/16-24, 3/8-24, 7/16-20, 1/2-20, 1/8NPT, 3MM X 0.5, 4MM X 0.7, 5MM X 0.8, 6MM X 1.01, 7MM X 1.02, 8MM X 1.25, 9MM X 1.25, 10MM X 1.00, 10MM X 1.50, 12MM X 1.75		
<b>Outside diameter of round dies:</b> 1/4 to 3/8 - 1" O.D. 7/16 to 5/8 - 1-1/2" O.D. 3/4 TO 1 - 2" O.D.		
<b>Also Includes:</b> 2 Straight Tap Wrenches and 3 Die Stocks: 1", 1-1/2" and 2"		
Description	Order No.	Price
High Speed Steel	5210060	
Carbon Steel	0500060	



**CARBON STEEL  
TAP AND DIE SETS**

SERIES 843:



**CUTTING TOOLS - TAPS & DIES**

## 25-PIECE TAP AND DIE MASTER SET -

### 9/16" THROUGH 1"

Includes Coarse & Fine Threads

Packed in a hinged plastic case. Includes 1 each Plug Tap and 1 each Round Die for the following Thread Sizes: 9/16-12, 9/16-18, 5/8-11, 5/8-18, 3/4-10, 3/4-16, 7/8-9, 7/8-14, 1-8, 1-14, 1/4-18NPT

**Also Includes:**

Adjustable Die Stock - 1-1/2" Round,  
Adjustable Die Stock - 2" Round,  
Adjustable Handle Tap Wrench

Order No. 4398000

Price



## 39-PIECE TAP AND DIE SET -

### NO. 4 THROUGH 1/2"

Includes Coarse & Fine Threads

Packed in a hinged plastic case with removable tray. Includes 1 each Plug Tap and 1 each Solid Round Die for the following Thread Sizes:

4-40, 6-32, 8-32, 10-24, 10-32, 12-24,  
1/4-20, 1/4-28, 5/16-18, 5/16-24, 3/8-16, 3/8-24,  
7/16-14, 7/16-20, 1/2-13, 1/2-20, 1/8-27NPT.

**Also includes:**

Adjustable Die Stock, Adjustable Handle Tap Wrench,  
T-Handle Tap Wrench, Screw Pitch Gauge, Screwdriver.

Order No. 4323614

Price

## 41-PIECE TAP AND DIE SET -

### NO. 4 THROUGH 1/2"

Includes Coarse & Fine Threads

Packed in a hinged plastic case with removable tray. Includes one each Plug Tap and Hexagon Die for the following Thread Sizes:

4-40, 6-32, 8-32, 10-24, 10-32, 12-24,  
1/4-20, 1/4-28, 5/16-18, 5/16-24, 3/8-16, 3/8-24,  
7/16-14, 7/16-20, 1/2-13, 1/2-20, 1/8-27NPT

**Also includes:**

Plain Die Stock, Adjustable Die Stock, Adjustable Handle Tap Wrench, T-Tap Wrench, T-Tap Wrench with 3/8" Square Drive, Screw Pitch Gauge, Screwdriver.

Order No. 4324606

Price

## 41-PIECE TAP AND DIE SET -

### 3mm THROUGH 12mm

Includes Coarse & Fine Threads

Packed in a hinged plastic case with removable tray. Includes one each Plug Tap and Hexagon Die for the following Thread Sizes:

3-.50, 4-.70, 4-.75, 5-.80, 5-.90, 6-1.00, 7-1.00, 8-1.00, 8-1.25, 9-1.00,  
9-1.25, 10-1.25, 10-1.50, 11-1.50, 12-1.50, 12-1.75,  
1/8-28BSP

**Also includes:**

Plain Die Stock, Adjustable Die Stock, Adjustable Handle Tap Wrench, T-Tap Wrench, T-Tap Wrench with 3/8" Square Drive, Screw Pitch Gauge, Screwdriver.

Order No. 4326317

Price

## 66 - PIECE TAP AND DIE MASTER SET -

### NO. 4 THROUGH 1"

Packed in a hinged plastic case with removable plastic trays.

Includes one each Plug Tap and one each Hexagon Die for the following Thread Sizes:

4-40, 6-32, 8-32, 10-24, 10-32, 12-24,  
1/4-20, 1/4-28, 5/16-18, 5/16-24, 3/8-16, 3/8-24,  
7/16-14, 7/16-20, 1/2-13, 1/2-20, 9/16-12, 9/16-18, 5/8-11, 5/8-18,  
3/4-10, 3/4-16, 7/8-9, 7/8-14, 1-8, 1-14, 1/8-27NPT, 1/4-18NPT

**Also includes:**

Adjustable Die Stocks: 1", 1-7/16", 1-13/16", Plain Die Stock: 5/8"  
Adjustable Handle Tap Wrenches (2), Two-in-One Tap Wrench,  
Screw Pitch Gauge

Order No. 4397606

Price

## RECTANGULAR TOOL BITS

SERIES 614: M2 STEEL

SERIES 615: COBALT (5%) STEEL



Additional sizes available; please inquire.

Overall Size	Length	M2		Cobalt (5%)	
		Order No.	Price	Order No.	Price
1/4x3/8	3	6141624		206616	
1/4x3/8	4	-		6151624	
1/4x1/2	4	6141632		6151632	
1/4x3/4	5	6141648		6151648	
1/4x1	6	6141664		6151664	
5/16x1/2	4	6142032		6152032	
5/16x3/4	5	6142048		6152048	
5/16x1	6	6142064		6152064	
3/8x1/2	4	6142432		6152432	
3/8x5/8	4-1/2	6142440		6152440	
3/8x3/4	5	6142448		6152448	
3/8x1	6	6142464		6152464	
1/2x3/4	6	6143248		6153248	
1/2x1	7	6143264		6153264	
1/2x1-1/4	7	6143280		-	
5/8x3/4	5	6144048		6154048	
5/8x7/8	6	6144056		206652	
5/8x1	7	6144064		6154064	
5/8x1-1/4	7	6144080		-	
3/4x1	6	6144864		-	
3/4x1-1/4	6	6144880		-	
3/4x1-1/4	7	6144881		-	
1x1-1/4	6	206766		206666	